

AMPEX
AUDIO-VIDEO
SYSTEMS DIVISION

AG-440B/AG-445B
CAPSTAN SERVO KIT

INSTALLATION
OPERATION

CATALOG NO. 4890319-02
ISSUED: 16 AUGUST 1972

ERRATA

Date 13 December 1972

PUBLICATION AG-440B/AG-445B Capstan Servo Kit

No. 1

Installation and Operation Manual 4890319-02

REASON FOR ERRATA To correct oscilloscope Test Point Reference in Gain Adjustment Procedure

Page Reference	Nature of Errata
13	Step 2: Connect scope probe to Test Point 2 of the capstan servo PWA instead of to pin 6.

AG-440B/AG-445B CAPSTAN SERVO KIT

**INSTALLATION
OPERATION**

**AMPEX CORPORATION
AUDIO-VIDEO SYSTEMS DIVISION**

Prepared by

Audio-Video Technical Publications MS 22-03

Ampex Corporation

401 Broadway

Redwood City, CA 94063

Catalog No. 4890319-02

Issued: 16 August 1972

Printed in USA

TABLE OF CONTENTS

	Page
GENERAL INFORMATION	1
INSTALLATION	3
THEORY OF OPERATION	7
OPERATION	11
SPEED PAIR SELECTION	11
VARIABLE TAPE SPEED MODE	11
GAIN ADJUSTMENT	13
PARTS LISTS AND SCHEMATIC DIAGRAMS	14

GENERAL INFORMATION

This manual is a supplement to be used in conjunction with the basic Ampex AG-440B and AG-445B Recorder and Reproducer manual 4890301-03. Supplementary information in this publication describes installation and operation of the AG-440B/AG-445B Capstan Servo Kit, catalog number 4859145. The kit comprises the following main components:

1. Capstan motor/tachometer, part number 4020352.
2. Servo chassis assembly, part number 4020362-02.
3. Take-up idler arm.
4. Capstan dust cover.

The function of the capstan servo kit is to improve transport performance by making tape speed entirely independent of power line voltage and frequency variations. The kit also expands the number of tape speed pairs which can be assigned to the existing high/low tape SPEED switch. That is, the two-position tape SPEED switch can be connected, by means of jumpers, to select any two of the following four standard tape speeds: 3.75 in/s, 7.5 in/s, 15 in/s and 30 in/s. Tape speed can also be controlled externally over the range of 3.00 in/s to 45 in/s by means of an external reference signal source. Refer to the maintenance section for details regarding both internal and external tape speed selection.

When used in conjunction with the AG-440B/AG-445B Sync-Lock Kit (catalog number 4020391), the capstan servo kit also permits capstan speed synchronization with a control track or standard pilot tone signal.

Table 1 lists specifications for the modified AG-440B/AG-445B. Because of possible design improvements or equipment modifications, all specifications are subject to change without notification.

Table 1. Modified AG-440B/AG-445B Specifications

PARAMETER	SPECIFICATIONS		
Tape Speeds	3.75 in/s, 7.5 in/s, 15 in/s, and 30 in/s in speed pairs		
Start-up Time	0.1 second to operating speed 3.0 seconds to flutter specifications		
Flutter		Weighted DIN	Unweighted NAB
	30 in/s	0.06%	0.05%
	15 in/s	0.06%	0.06%
	7.5 in/s	0.08%	0.08%
	3.75 in/s	0.1%	0.1%
Tape Speed Accuracy	±0.08% from beginning to end of reel		

INSTALLATION

Install the capstan servo kit as follows:

1. Loosen the transport-position retaining nut and tilt the front of the transport up to the limit of its travel. Hand tighten the transport-position retaining nut. Remove the front cover by loosening the two retaining screws.
2. Using a 5/64 Allen wrench, remove the capstan idler from the idler arm.
3. Remove the dust cover from the capstan. See Figure 1.
4. Supporting the weight of the capstan motor, remove the four retaining screws from the top side of the transport plate. Carefully remove the capstan motor and hum shield.
5. Remove the capstan motor capacitor from the underside of the transport casting. Refer to Figure 2.
6. Loosen the transport-position retaining nut and tilt the transport back down to the horizontal position. Hand tighten the retaining nut.
7. On some machines it is necessary to enlarge the hole in the transport plate occupied by the capstan motor. Check the size of the hole in the machine against the size required by the dc capstan motor included in the kit.
8. If necessary, the capstan hole can be enlarged by using the supplied template and a half-round file. Care must be exercised to ensure that the enlarged hole remains centered with respect to the four mounting screws.

CAUTION

DURING THE FILING OF THE TRANSPORT PLATE, BE SURE THAT NO METAL PARTICLES ENTER ANY OF THE ELECTRONIC OR MECHANICAL COMPONENTS INSIDE THE MACHINE. FAILURE TO HEED THIS WARNING MAY RESULT IN SERIOUS DAMAGE TO THE EQUIPMENT.

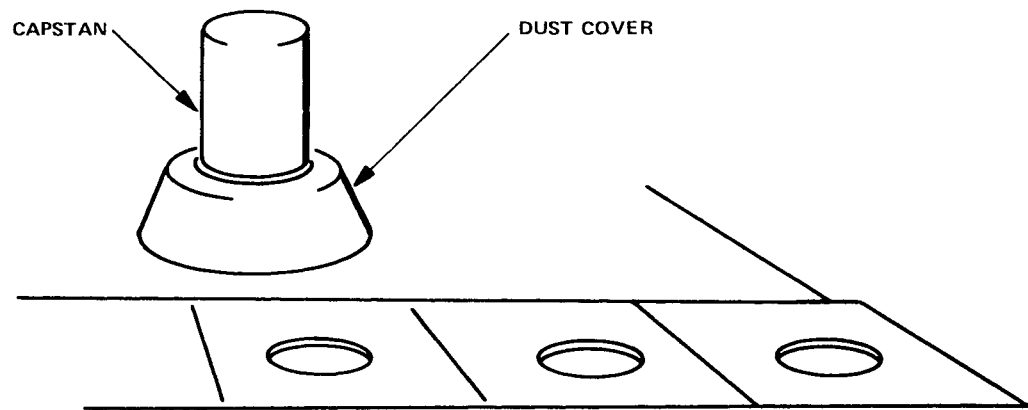

Figure 1. Dust Cover Position

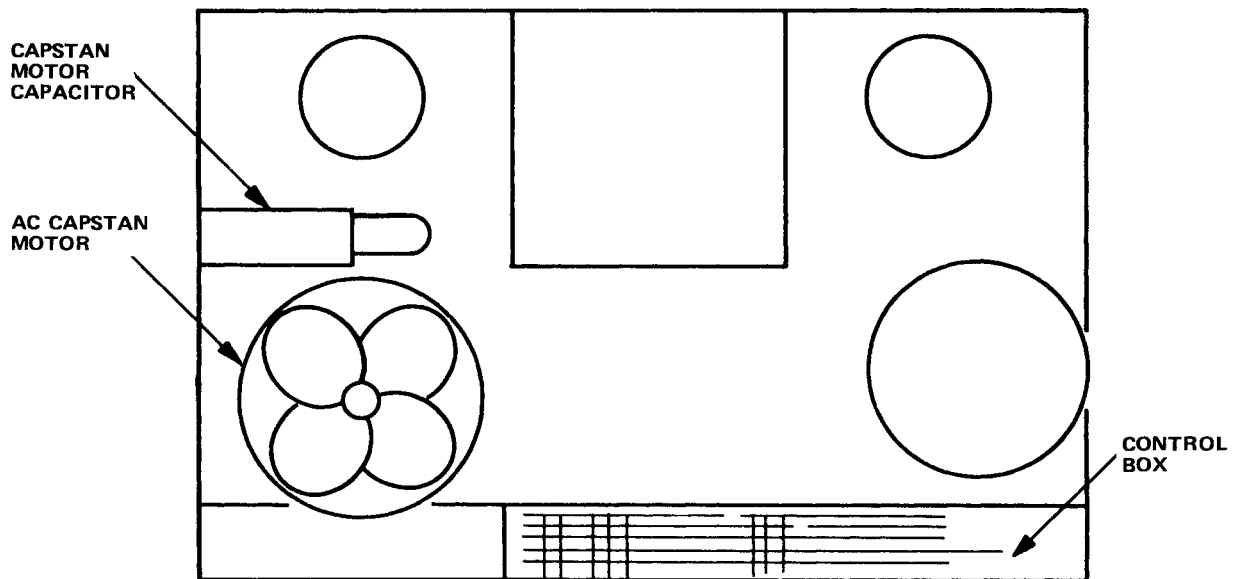

Figure 2. Underside of Transport Assembly

9. Loosen the transport-position retaining nut and tilt the front of the transport to the limit of its travel. Hand tighten the transport-position retaining nut.
10. Install the new dc capstan motor (part number 4020352, version -02 for the one-half inch capstan, version -03 for the one-inch capstan) with its tachometer pickup side toward the take-up reel. Install and tighten the four retaining screws.

11. Install the capstan servo chassis included with the kit (part number 4020362-01) on the rear panel of the AG-440B/445B as shown in Figure 3. Use the hardware supplied. The precise location of the servo chassis on the rear panel is not critical.
12. Thread the cable assembly from the previously installed dc capstan motor through the opening in the rear panel of the AG-440B/445B and connect to J6 on the servo chassis as shown in Figure 3.
13. Thread the cable assembly emerging from the servo chassis through the opening in the rear panel of the AG-440B/445B and mate the connector with the jack designated CAPSTAN MOTOR on the control box. Connect the two knife disconnects to the correspondingly colored leads originally connected to the capstan motor capacitor.
14. In the rear and underside portions of the machine, use the supplied nylon tie-wraps to dress the cables away from the motors, and to relieve any strain.
15. Replace the front cover initially removed in step 1. Return the transport to the horizontal position and hand tighten the transport-position retaining nut.
16. Replace the capstan idler on the idler arm.
17. Place the round aluminum dust cover on the capstan bearing support as shown in Figure 1.
18. Obtain the dummy plug from the kit and install into J4 on the lower side of the servo chassis previously mounted on the rear panel of the machine.
19. Readjust capstan idler pressure as described in AG-440 manual.

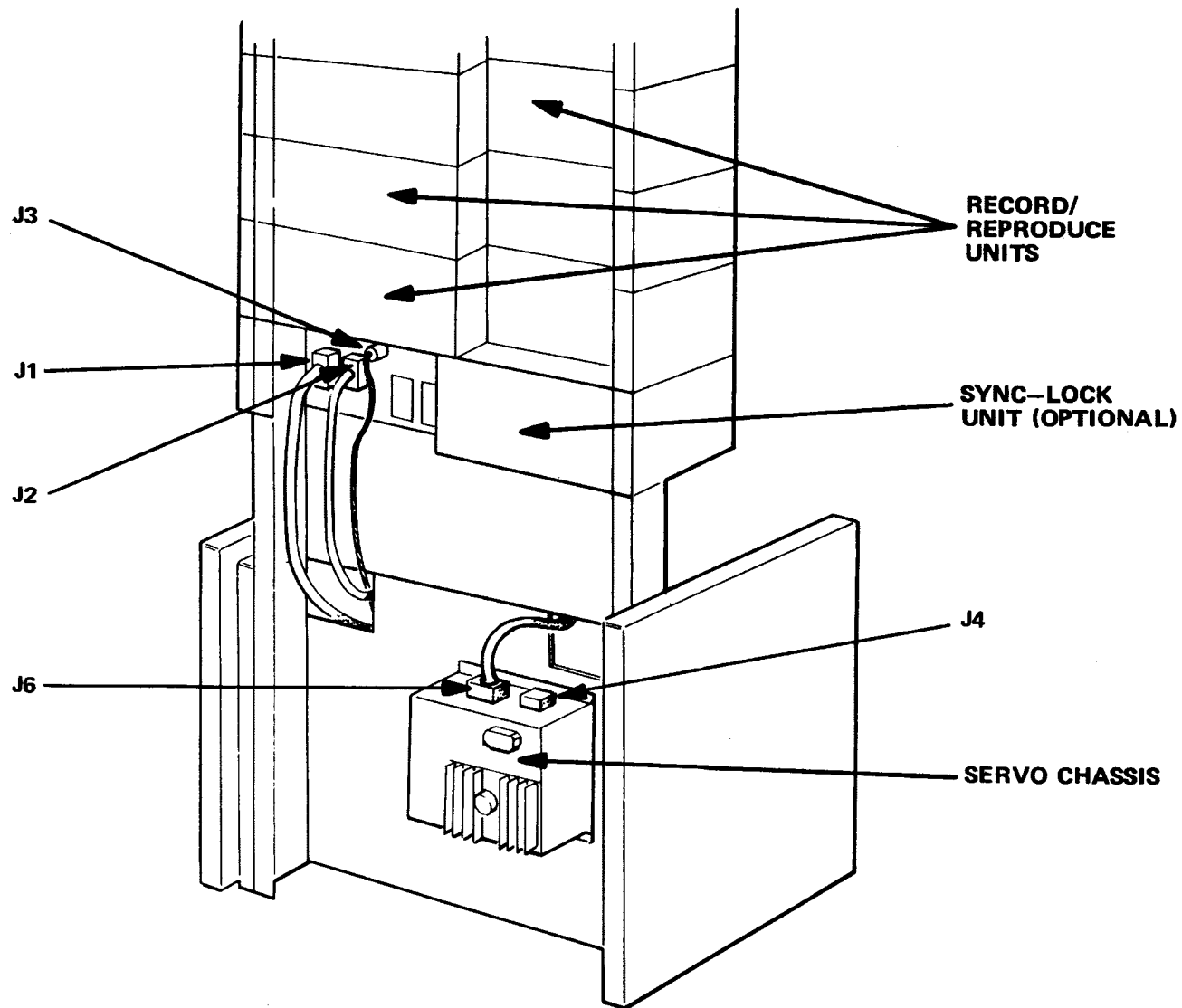

Figure 3. Servo Chassis Location

THEORY OF OPERATION

The capstan servo system uses a high torque, direct drive, dc motor which employs a closed-loop servo for speed control. The servo system provides four tape speeds, which may be strapped in pairs to the SPEED switch on the transport control panel. The kit consists of a dc power supply, a motor drive amplifier, a dc capstan motor with tachometer, a reference oscillator, a selectable frequency divider, a phase comparator, and a low-pass filter. Except for the dc power supply and the dc capstan motor, all electronic circuitry is contained on a printed wiring assembly mounted inside the servo chassis.

The servo drive system operates on the output of the dc power supply. Direct speed control of the dc capstan motor is provided by the motor drive amplifier, which regulates the supply of dc power to the motor in accordance with servo requirements to maintain precise capstan speed.

During operation of the AG-440B or AG-445B with the servo kit, tachometer pulses are provided at a rate proportional to capstan speed. As shown in Figure 4, the tachometer pulses are amplified and fed to a digital phase comparator. The other input to the phase comparator is provided by the reference oscillator, the output of which is divided down to the frequency required to obtain the desired capstan speed. The tachometer pulses are compared with the selected reference frequency, and any frequency difference between them causes the comparator to produce a corresponding output voltage. If the capstan motor slows down for any reason, the output of the phase comparator causes the motor drive amplifier to provide more current to the capstan motor. This servo action increases the speed of the capstan to help compensate for the slowdown. Conversely, if the capstan motor speeds up, the phase comparator causes a slow-down of the motor accordingly. In this manner, small variations in capstan speed are overcome.

When a different tape speed is selected, a large change in the selected reference frequency applied to the phase comparator results. For example, if operation is taking place at a selected tape speed of 7.5 in/s, and a new speed of 3.75 in/s is selected on the SPEED switch, the reference input to the phase comparator changes from 2400 Hz to 1200 Hz. This causes the output of the phase comparator to produce a minimum dc level to the integrating amplifier and motor drive amplifier. As a result, the capstan motor slows down.

As the capstan speed approaches 3.75 in/s, the phase comparator produces a series of pulses whose width is proportional to the phase difference between the tachometer pulses and reference frequency. The capstan continues to slow down until the pulses from the phase comparator have a 20% duty cycle. (This permits a greater amount of corrective torque in the positive, or "speed up" condition.) At this time, sufficient motor drive current is maintained to cause a capstan speed of 3.75 in/s. Again, any variation in capstan speed is detected by the phase comparator, which in conjunction with the integrating amplifier, brings about the corrective change in capstan drive current to maintain proper tape speed.

The reference oscillator and divider is crystal-controlled and produces a 9600-Hz square-wave output to the selectable frequency divider network. The divider provides division of the reference frequency by factors of 2, 4, and 8 as selected by the strapping arrangement in conjunction with the SPEED switch. If the 30-in/s tape speed is selected, the output of the reference oscillator is fed undivided (shown in Figure 4 as divided by one) to the phase comparator. If the capstan is not turning at the 30-in/s rate, there will be a significant frequency difference between the 9600-Hz output of the reference oscillator and the tachometer pulses. As a result, a significant error voltage is developed which causes an increase in the motor drive amplifier output, causing the capstan to speed up until the tachometer pulses are synchronous with the reference oscillator output.

When a lower capstan speed is selected, the reference oscillator is divided by a factor of 2, 4, or 8, depending upon which tape speed is selected. Since the reference frequency is now lower than that of the tachometer output, the error voltage developed by the phase comparator and integrating amplifier causes the motor drive amplifier to reduce its output to the capstan motor. This action causes the capstan motor to slow down to the selected tape speed where the phase comparator in conjunction with the integrating amplifier produces the amount of control voltage necessary to maintain the proper speed of the capstan.

The servo operates in a similar manner when the reference oscillator is replaced with an external square-wave generator. That is, the capstan motor will be caused to adjust its speed so that the tachometer pulses are synchronous with the externally-generated reference frequency.

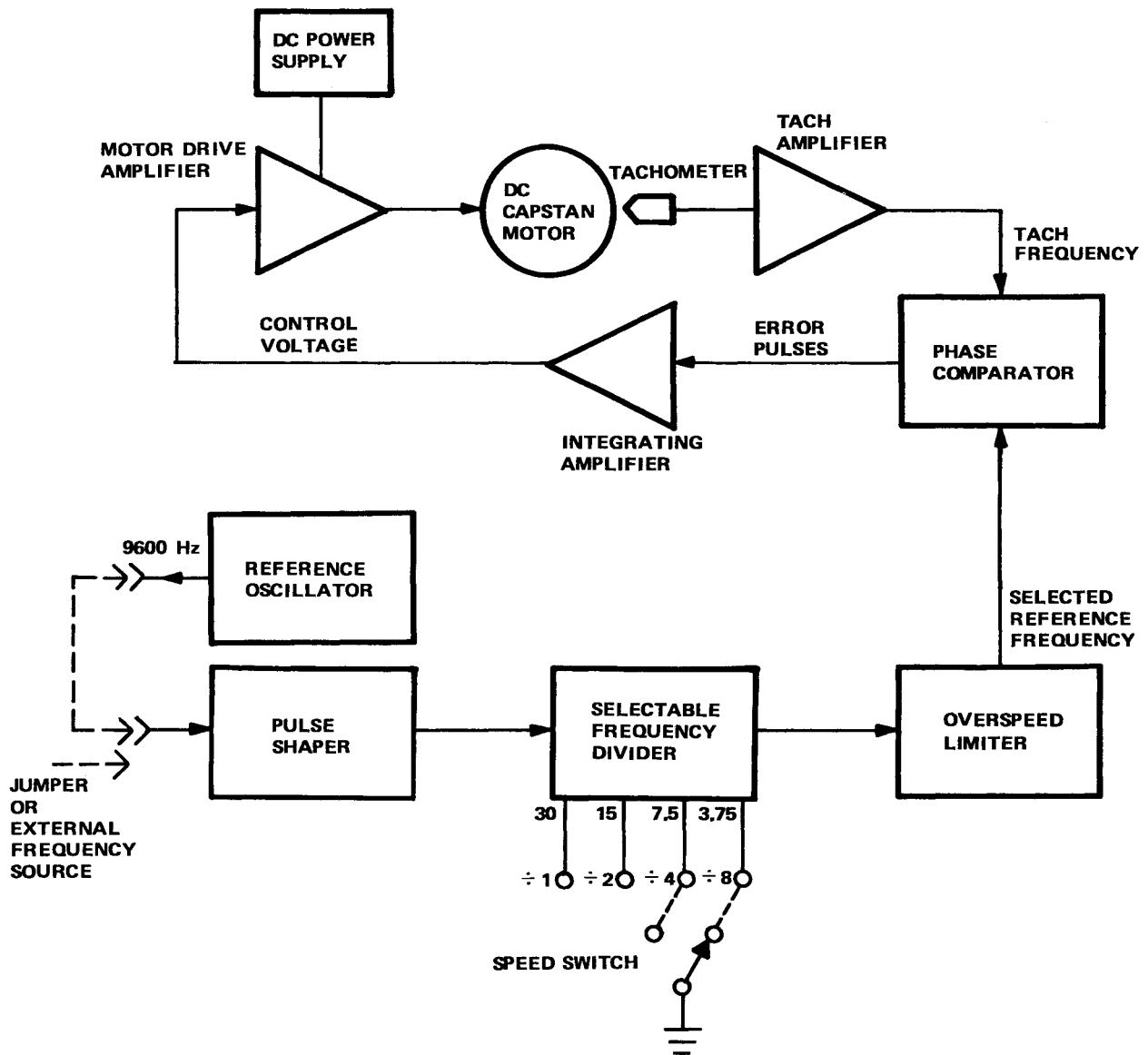

Figure 4. Capstan Servo Block Diagram

OPERATION

SPEED PAIR SELECTION

The front panel SPEED switch on the AG-440B and AG-445B permits the selection of the high or low operating speed. The assignment of the high and low operating speeds is determined by a strapping arrangement on the servo printed wiring assembly. Selected tape operating speeds may be any two of the following: 30 in/s, 15 in/s, 7.5 in/s and 3.75 in/s. Strap the speed pair as follows:

1. On the transport control panel, set the switch to OFF.
2. Slide the servo printed wiring assembly out of the servo chassis.
3. Connect a jumper from the terminal associated with the low position of the SPEED switch, designated E2, to the terminal associated with the desired low tape speed (E1, E3 or E4). Refer to Figure 5.
4. Connect a jumper from the terminal associated with the high position of the SPEED switch, designated E5, to the terminal associated with the desired high tape speed (E3, E4 or E6).
5. Replace the servo printed wiring assembly in the servo chassis, component side rearward (i.e., facing away from the AG-440B/445B).

VARIABLE TAPE SPEED MODE

The use of the dummy plug in J4 of the servo chassis causes the capstan servo to operate with a fixed reference frequency of 9.6 kHz. To operate the system at variable tape speeds, remove the dummy plug from J4 and connect a sine or squarewave generator having an output of 3 to 30 vrms across pins 2 and 3 (ground) of a similar plug. Refer to Figure 6.

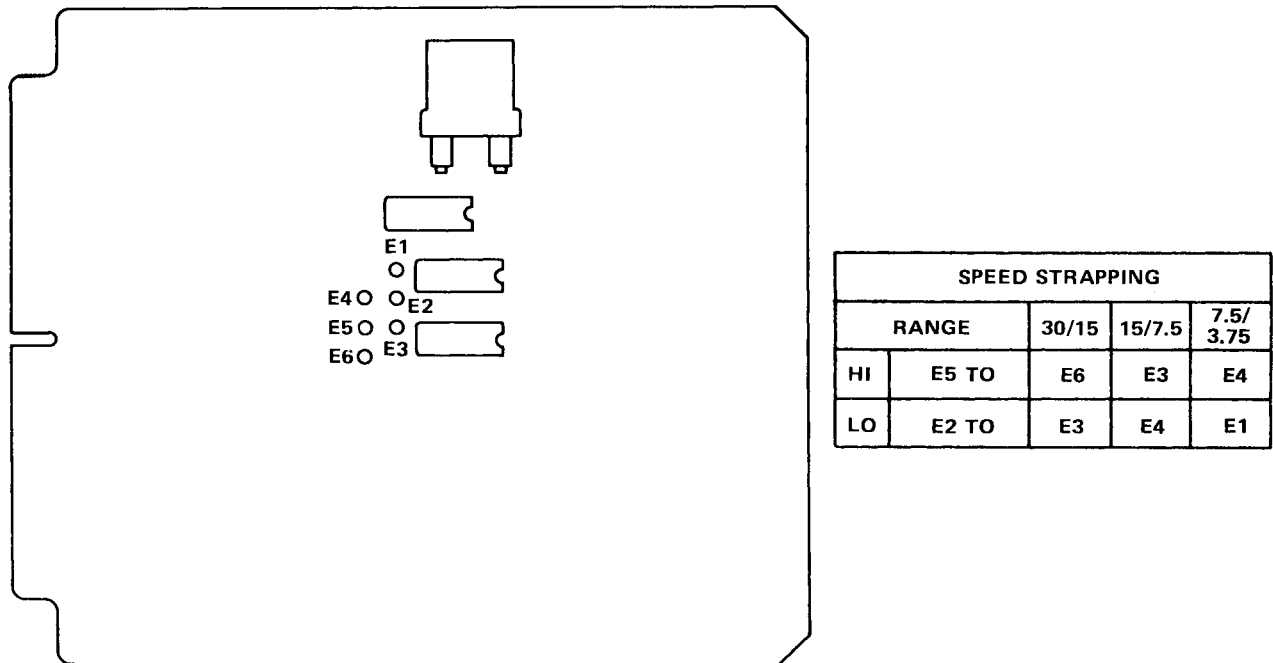

Figure 5. Tape Speed Pan Strapping

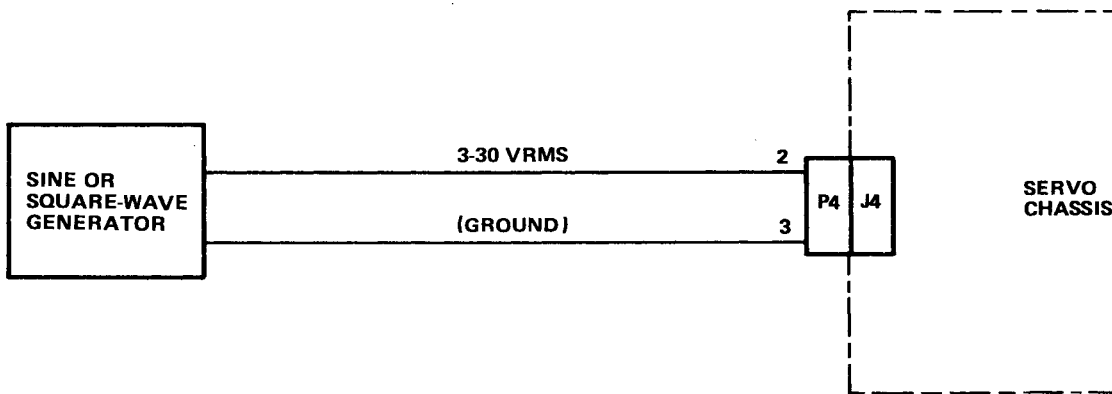

Figure 6. Connection of Square-wave Generator

Insert the new plug into J4 on the servo chassis. If a similar plug is not available, the dummy plug can be modified by removing the existing jumper between pins 1 and 4 and connecting the generator as described above. Once connected, the frequency of the generator can be used to control the speed of the tape in accordance with the values given in Table 2.

Table 2. Tape Speeds for Various Reference Frequency Inputs

TAPE SPEED (IN/S)	INPUT FREQUENCY
3.75	1200
7.5	2400
15	4800
30	9600

NOTE

The values given in Table 2 are with the SPEED switch in the "high" position and jumper set for 30 in/s.

GAIN ADJUSTMENT

This adjustment should be made only when a change in major components of the capstan servo system makes it necessary.

1. Put the capstan-servo PWA on extender PWA 4050695.
2. Attach a scope probe to pin 6 of the capstan servo PWA.
3. Put recorder in Play.
4. Adjust R19 on capstan servo PWA for minimum signal jitter.

PARTS LISTS AND SCHEMATIC DIAGRAMS

TITLE	DRAWING NO.	PAGE NO.
Capstan Servo Kit	4850145B	15
Schematic, Capstan Servo Chassis	4840355A	16
Dummy Plug Assembly, Remote Control	4050710—	17
Chassis Assembly, Capstan Servo	4020362B	18
Cable Assembly, Power	4050664—	19
Capstan Servo PWA	4050692B	20
Schematic, Capstan Servo PWA	4840356—	22

NUMERICAL INDEX

DRAWING NO.	TITLE	PAGE NO.
4020362B	Chassis Assembly, Capstan Servo	18
4050664—	Cable Assembly, Power	19
4050692B	Capstan Servo PWA	20
4050710—	Dummy Plug Assembly, Remote Control	17
4840355A	Schematic, Capstan Servo Chassis	16
4840356—	Schematic, Capstan Servo PWA	22

AMPEX

Ampex Corporation
REDWOOD CITY, CALIFORNIA

LIST OF MATERIALS

LM-4850145
SHEET 1 OF 1

E

REVISIONS				CODE IDENT NO.	TITLE
LTR	DESCRIPTION	DATE	APPROVED	92739	CAPSTAN SERVO ASSEMBLY KIT
-	PRODUCTION RELEASE	12/3/71kt			
A	SEE ECN 54478-2, ADD-02	4/14/72kt	<i>[Signature]</i>	-01 SEE TAG	SIGNATURE
B	SEE ECN 54748-8	7-8-72	<i>[Signature]</i>	-02 1/4" & 1"	
				-03 1"	
					DRAWN BY
					CHECKED BY
				CATALOG AG440-8	ENGR APPD
				CATALOG AG-440/445	APPD BY
				NEXT ASSEMBL. USED ON	
APPLICATION					

ITEM NO.	PART NUMBER	DESCRIPTION	REF DESIG	QTY REQD PER DASH NUMBER		
				-01	-02	-03
1	4020352-01	SERVO MOTOR ASSY			-	-
2	4020362-01	CHASSIS ASSY, CAPSTAN SERVO			-	-
3	4050710-01	DUMMY PLUG ASSY			1	1
4	4050659-01	DUMMY PLUG			-	-
5	4100198-02	JUST CAP, CAPSTAN			1	1
6	4230259-01	TENSION ARM			1	1
7	440372-01	WASHER, PCL			1	-
8	4840304	SCHEMATIC, CAPSTAN SERVO KIT	REF		-	-
9	4890319	MANUAL			1	1
10	4930510-01	HOLE TEMPLATE			1	1
11	4840355	SCHEMATIC, CAPSTAN SERVO CHASSIS			REF	REF
12						
13	471-470	SCREW, MACH, PAN HD, 6-32 x 1 1/4		4	4	4
14						
15	496-005	NUT, KEPS, 6-32		4	4	4
16						
17	501-009	WASHER, PLAIN #6		8	8	8
18						
19						
20	4020352-02	SERVO MOTOR ASSY 1/2"			1	-
21	4020362-02	CHASSIS ASSY, CAPSTAN SERVO			1	1
22	4020352-03	SERVO MOTOR ASSEMBLY, 1"			-	1
23	4290659-01	SHIELD, RESISTOR			1	1
24						
25						
26						
27						

15 Capstan Servo Kit LM No. 4850145B

Capstan Servo Chassis Schematic Dwg. No. 4840355A
 Ref. Assy. No. 4850145

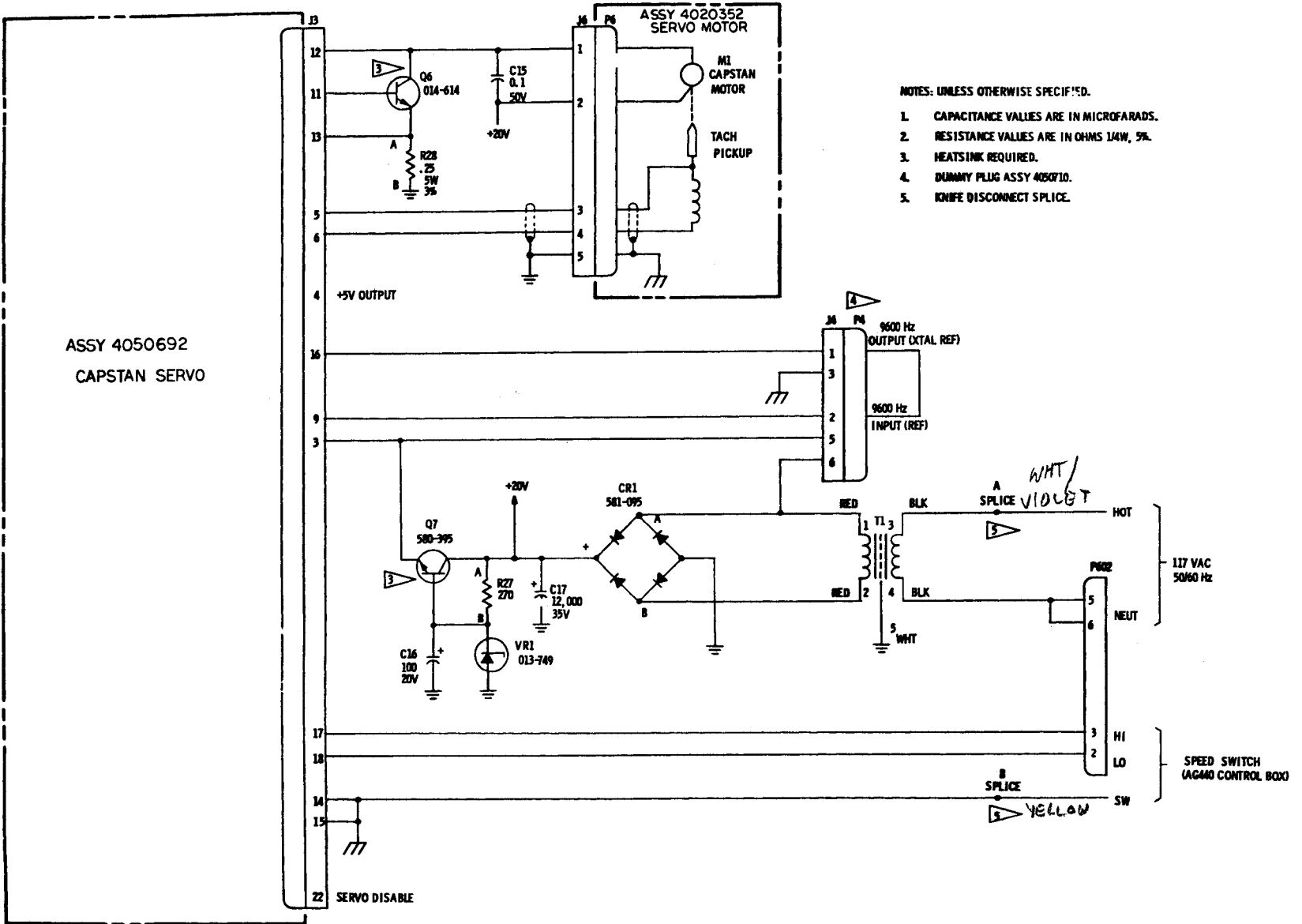

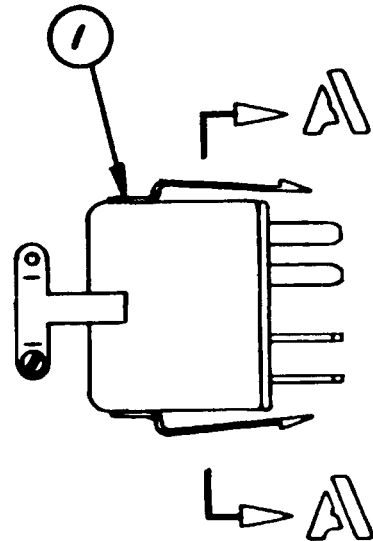
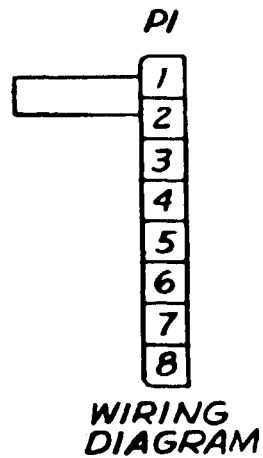
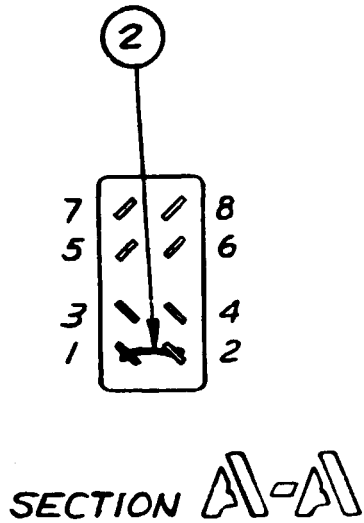

NOTES:

1. PART NO. IS 4050710-01.
2. MARK PART NO. PER BDI-1.

$\frac{1}{R}$	2	615-012	WIRE, BARE, 20AWG
1	1	145-013	CONNECTOR, SIGNAL CIRCUIT, 8 PINS
-01	ITEM NO	PART NUMBER	DESCRIPTION
PARTS LIST			

**Remote Control Dummy Plug Assembly Dwg. No. 4050710-
Next Assy. No. 4850145**

AMPEX		Amplex Corporation REDWOOD CITY, CALIFORNIA		LIST OF MATERIALS		LM-4020362		SHEET 1 OF 2		C	
REVISIONS				CODE IDENT NO.	TITLE						
LTR	DESCRIPTION	DATE	APPROVED	92739	CHASSIS ASSEMBLY, CAPSTAN SERVO						
-	PRODUCTION RELEASE	12/3/71	[Signature]		SIGNATURE						
A	SEE ECH 54501-2	4/18/72	MJA		DATE						
B	SEE ECH 54716	7/17/72	MJA		DRAWN BY						
C	SEE ECH 54820	8/15/72	MJA		CHECKED BY						
					ENGR APPD						
					APPD BY						
					NEXT ASSEMBLY USED ON						
					APPLICATION						
ITEM NO.	PART NUMBER	DESCRIPTION			REF DESG	QTY REQD PER DASH NUMBER					
						-01	-02				
1	1228243-01	TRANSFORMER, POWER			T1		1				
2	4050642-01	CHASSIS, CAPSTAN SERVO									
3	4050644-01	CABLE, POWER					1				
4	4050642-02	PWA, CAPSTAN SERVO					1				
5	4260490-01	CHASSIS, CAPSTAN SERVO									
6	4260490-03	CHASSIS, CAPSTAN SERVO					1				
7											
8	013-603	DIODE, BRIDGE ASSY			CR1		1				
9	013-749	DIODE, ZENER, 1W, 13V			VR3		1				
10	014-614	TRANSISTOR, NPN, POWER			Q6		1				
11											
12	030-145	CAPACITOR, CER., 0.1uF, 50V			C15		1				
13	063-149	CAPACITOR, ELECTROLYTIC, 15,600uF, 50V			C17		1				
14	037-620	CAPACITOR, TANT., 100uF, 20V			C16		1				
15	041-503	RESISTOR, COMP, 270R, 1/2W, 5%			R27		1				
16	043-668	RESISTOR, WIRE WOUND, 250, 5W, 3%			R28		1				
17											
18	065-004	BRACKET, CAPACITOR MOUNTING					1				
19											
20	138-087	CONNECTOR, 6P, 10 CONTACTS									
21	146-006	CONNECTOR, 6 CONTACT, FEMALE			CHASSIS MOUNT J6		1				
22	146-003	CONNECTOR, 8 CONTACT, FEMALE			CHASSIS MOUNT J4		1				
23	143-804	CONNECTOR, PWB, 28 CONTACTS					1				
24	166-438	KEY, PC CONNECTOR					1				
25	171-009	CONNECTOR, KNIFE DISCONNECT					2				
26	172-003	SOLDER LUG, #6					1				
27	172-005	SOLDER LUG #10					4				
28	180-023	TERMINAL STRIP, 2 TERMINALS					1				
29	180-143	TERMINAL STRIP, 5 TERMINALS					2				
30											
31	260-017	GROMMET, 3/8 I.D.					1				
32											
33	471-062	SCREW, MACH, PAN HD, 4-40 X 3/8					1				
34	471-064	SCREW, MACH, PAN HD, 4-40 X 1/2					4				
35	471-085	SCREW, MACH, PAN HD, 4-40 X 5/8					2				
36	471-087	SCREW, MACH, PAN HD, 6-32 X 1/4					3	13			
37	471-470	SCREW, MACH, PAN HD, 6-32 X 1/4					2				

AMPEX		Amplex Corporation REDWOOD CITY, CALIFORNIA		LIST OF MATERIALS		LM-4020362		SHEET 2		C
ITEM NO.	PART NUMBER	DESCRIPTION			REF DESG	QTY REQD PER DASH NUMBER				
						-01	-02			
38										
39										
40	492-034	NUT, PLAIN, SMALL PATTERN, 6-32					2			
41	496-004	NUT, NPS, 4-40						7		
42	496-005	NUT, NPS, 6-32						13		
43										
44	501-008	WASHER, PLAIN, #4						4		
45	501-188	WASHER, PLAIN, #6, SMALL PATTERN						2		
46	502-003	WASHER, LOCK, SPRING, #6						2		
47										
48	530-102	GUIDE, P.C. CARD						2		
49	580-165	HEATSINK							1	
50	580-395	TRANSISTOR, NPN, POWER			Q7				1	
51										
52										
53	611-220	WIRE, INS, 18 AWG, BROWN							A/R	A/R
54	611-256	WIRE, INS, 20 AWG, BLACK							A/R	A/R
55	611-536	WIRE, INS, 18 AWG, RED							A/R	A/R
56	611-543	WIRE, INS, 22 AWG, WHT/BRN							A/R	A/R
57										
58	616-875	WIRE, INS, 24 AWG, WHT/BLU							A/R	A/R
59	616-875	WIRE, INS, 24 AWG, WHT/BLU							A/R	A/R
60	617-050	WIRE, INS, 20 AWG, RED							A/R	A/R
61	617-053	WIRE, INS, 20 AWG, GREEN							A/R	A/R
62	617-054	WIRE, INS, 20 AWG, VIOLET							A/R	A/R
63	616-756	CABLE, SHIELDED, TWISTED PAIR							A/R	

Capstan Servo Chassis Assembly LM No. 4020362B
 Next Assy: No. 4850145

LM-4020362

Power Cable Assembly Dwg. No. 4050664-
Next Assy. No. 4020362

19

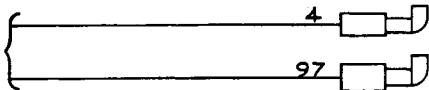
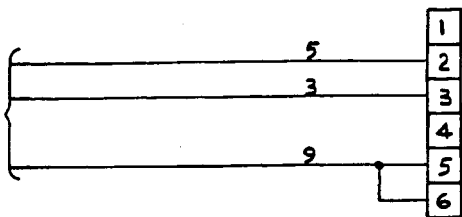
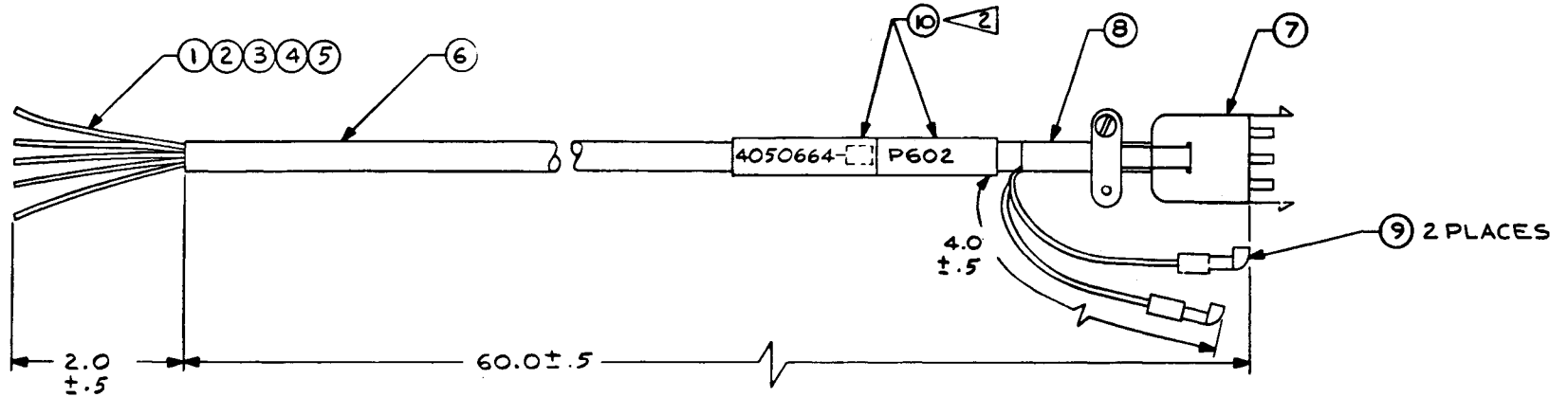

NOTES:

1. PART NO. IS 4050664-01
2. MARK PART NO PER BDI-1.

A/R	10	600-093	SLEEVING, POLYOLEFIN, SHRINKABLE, .375 EXPLD
	2	9 171-009	TERMINAL, QUICK-DISC, KNIFE TYPE
	1	8 262-003	BUSHING, SLEEVE, .312 I.D.
	1	7 145-012	CONNECTOR, SINGLE CIRCUIT, RECT PLUG, 6 PINS
A/R	6	600-009	SLEEVING, PVC, .208 I.D., BLK
A/R	5	617-052	WIRE, INS, 20 AWG, YEL
A/R	4	617-053	WIRE, INS, 20 AWG, GRN
A/R	3	617-050	WIRE, INS, 20 AWG, RED
A/R	2	617-063	WIRE, INS, 20 AWG, WHT/VIO
A/R	1	611-607	WIRE, INS, 20 AWG, WHT
-01	ITEM NO	PART NUMBER	DESCRIPTION
PARTS LIST			

AMPEX		Amplex Corporation REDWOOD CITY, CALIFORNIA		LIST OF MATERIALS		LM-4050692		SHEET 1 OF 2		B	
REVISIONS				CODE IDENT NO.	TITLE						
LTR	DESCRIPTION	DATE	APPROVED	92739	PRINTED WIRING ASSY CAPSTAN SERVO						
A	PRODUCTION RELEASE	4/19/72	<i>[Signature]</i>								
B	REV. ENR 54750	7/19/72	<i>[Signature]</i>								
				SIGNATURE		DATE					
				DRAWN BY		<i>[Signature]</i> 4/19/72					
				CHECKED BY							
				ENGR APPD		<i>[Signature]</i>					
				APPD BY		<i>[Signature]</i> 4/19/72					
				NEXT ASSEMBLY USED ON							
				APPLICATION							
ITEM NO.	PART NUMBER	DESCRIPTION	REF DESIG	QTY REQD PER DASH NUMBER							
1	4500209-02	PRINTED WIRING BOARD		1							
2	4800356	SCHEMATIC	REF								
3											
4	52528-01	HANDLE		1							
5											
6	013-678	DIODE, CD451	CR1	1							
7	013-883	DIODE, ZENER, .4W, 5.6V, CD32	VR1	1							
8											
9	014-652	TRANSISTOR, PNP, CD524	Q3, 7	2							
10	014-698	TRANSISTOR, NPN, CD562	Q1, 2, 6, 8	4							
11	014-793	HYG. PAD, TRANSISTOR	REF: Q1, 2, 6, 7, 8	5							
12	280-130	HYG. PAD, TRANSISTOR	REF: Q3	1							
13	017-122	CRYSTAL, MONITOR, PRODUCTS	Y1	1							
14	030-047	CAPACITOR, CER, DISC, .01uF, 100V, 20%	C2, 3, 6-8, 15, 16, 19	8							
15	030-437	CAPACITOR, MIMO, 0.1uF, 25V	C1, 9	2							
16											
17											
18	055-195	CAPACITOR, MYLAR, .0068uF, 50V, 5%	C18	1							
19											
20	034-283	CAPACITOR, MICA, 820pF, 300V, 5%	C22	1							
21	035-598	CAPACITOR, MYLAR, .04uF, 50V, 5%	C11	1							
22	035-853	CAPACITOR, MYLAR, .056uF, 50V, 5%	C13	1							
23	035-893	CAPACITOR, MYLAR, 0.1uF, 50V, 5%	C14	1							
24											
25											
26	037-347	CAPACITOR, TANT, 2.2uF, 20V, 10%	C17, 20	2							
27	037-620	CAPACITOR, TANT, 100uF, 20V, 10%	C5	1							
28	037-894	CAPACITOR, TANT, 100uF, 10V, 5%	C4, 21	2							
29	041-482	RESISTOR, COMP, 12K, 1/4W, 5%	R37	1							
30	041-484	RESISTOR, COMP, 22K, 1/4W, 5%	R18	1							
31	041-487	RESISTOR, COMP, 3.3K, 1/4W, 5%	R7, 8, 27, 34	4							
32	041-488	RESISTOR, COMP, 10K, 1/4W, 5%	R4, 9, 10, 22-24, 32	7							
33	041-410	RESISTOR, COMP, 1K, 1/4W, 5%	R5, 15, 30	3							
34	041-411	RESISTOR, COMP, 47K, 1/4W, 5%	R2	1							
35	041-412	RESISTOR, COMP, 4.7K, 1/4W, 5%	R14	1							
36	041-415	RESISTOR, COMP, 68K, 1/4W, 5%	R11	1							
37	041-443	RESISTOR, COMP, 33K, 1/4W, 5%	R1	1							

Capstan Servo PWA LM No. 4050692B
Next Assy: 4020362

20

LM-4050692

AMPEX		Amplex Corporation REDWOOD CITY, CALIFORNIA		LIST OF MATERIALS		LM-4050692		SHEET 2		C	
REVISIONS				CODE IDENT NO.	TITLE						
ITEM NO.	PART NUMBER	DESCRIPTION	REF DESIG	QTY REQD PER DASH NUMBER							
38	041-483	RESISTOR, COMP, 27K, 1/4W, 5%	R28, 35	2							
39	041-495	RESISTOR, COMP, 8.2K, 1/4W, 5%	R3	1							
40	041-502	RESISTOR, COMP, 240, 1/4W, 5%	R26	1							
41	041-503	RESISTOR, COMP, 270, 1/4W, 5%	R6	1							
42	041-504	RESISTOR, COMP, 510, 1/4W, 5%	R25	1							
43	041-514	RESISTOR, COMP, 9.1K, 1/4W, 5%	R20	1							
44	041-530	RESISTOR, COMP, 15, 1/4W, 5%	R29	1							
45	041-518	RESISTOR, COMP, 33K, 1/4W, 5%	R36	1							
46	041-394	RESISTOR, COMP, 100K, 1/4W, 5%	R3, 39	2							
47	041-653	RESISTOR, COMP, 390, 1/4W, 5%	R31	1							
48	055-133	CAPACITOR, MYLAR, .0022uF, 50V, 5%	C10	1							
49	055-168	CAPACITOR, MYLAR, .0056uF, 50V, 5%	C12	1							
50											
51	057-137	RESISTOR, METAL FILM, 51K, 1/4W, 2%	R12, 13, 16, 17, 21	5							
52	041-427	RESISTOR, 3300, 1/4W, 5%	R38	1							
53	058-754	RESISTOR, VAR, CER MET, 1000, 1W, 20%	R19	1							
54	143-981	CONNECTOR, JACK	E1-6	6							
55	150-104	HTC BRACKET, CRYSTAL	REF: Y1	1							
56	166-628	PLUG, SHORTING BLOCK, BLK		2							
57											
58	471-062	SCREW, X REC PAN HD, 4-40 X .375 LG		1							
59	492-008	NUT, PLAIN, HEX, 4-40		1							
60	501-008	WASHER, FLAT, #4		1							
61	502-024	WASHER, LOCK #4		1							
62											
63											
64	580-332	HEATSINK	REF: Q5	1							
65	580-395	TRANSISTOR, NPN, 2N5190	Q4, 5	2							
66											
67											
68	584-153	INTEGRATED CIRCUIT, MC846P	A7	1							
69	584-268	INTEGRATED CIRCUIT, UA741C	A4	1							
70	584-283	INTEGRATED CIRCUIT, SN7493N	A1	1							
71	584-309	INTEGRATED CIRCUIT, UA69601	A10	1							
72	584-425	INTEGRATED CIRCUIT, MC853P	A2, 3	2							
73	584-698	INTEGRATED CIRCUIT, UA6950	A6, 8, 9	3							
74	587-086	INTEGRATED CIRCUIT, 8 PIN, LM311N	A5	1							
75	586-680	INTEGRATED CIRCUIT, SN7413J	A11	1							

Capstan Servo PWA Dwg. No. 4050692B
 Next Assy. No. 4020362

21

NOTES:

1. PART NO. IS 4050692-02
2. MARK DASH NO. PER BDI-1.

SPEED STRAPPING			
RANGE	HI	MED	LO
HI	E5 TO E2	E5 TO E3	E5 TO E4
LO	E2 TO E3	E2 TO E4	E2 TO E1

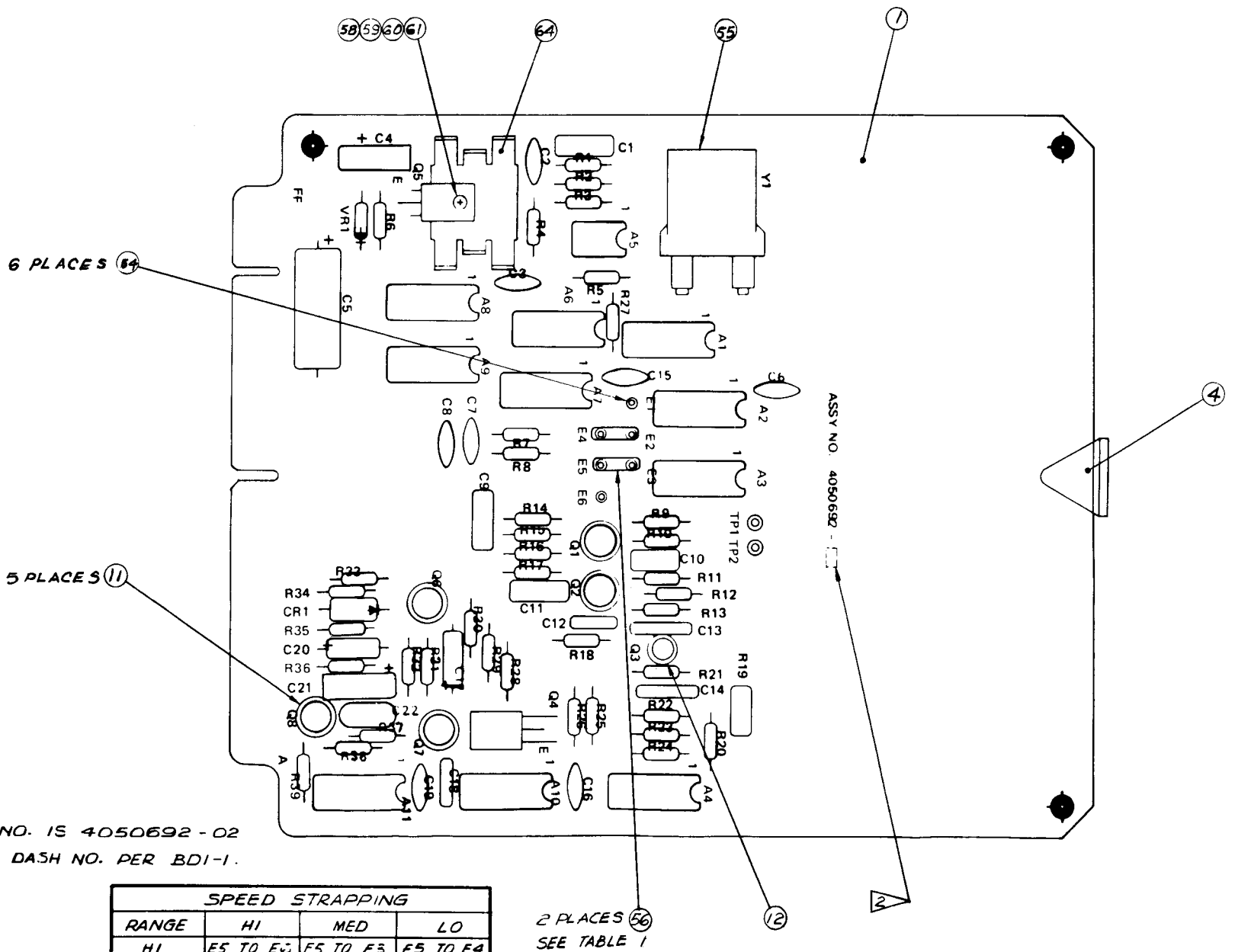

Capstan Servo PWA Schematic Dwg. No. 4840356
 Ref. Assy. No. 4050692

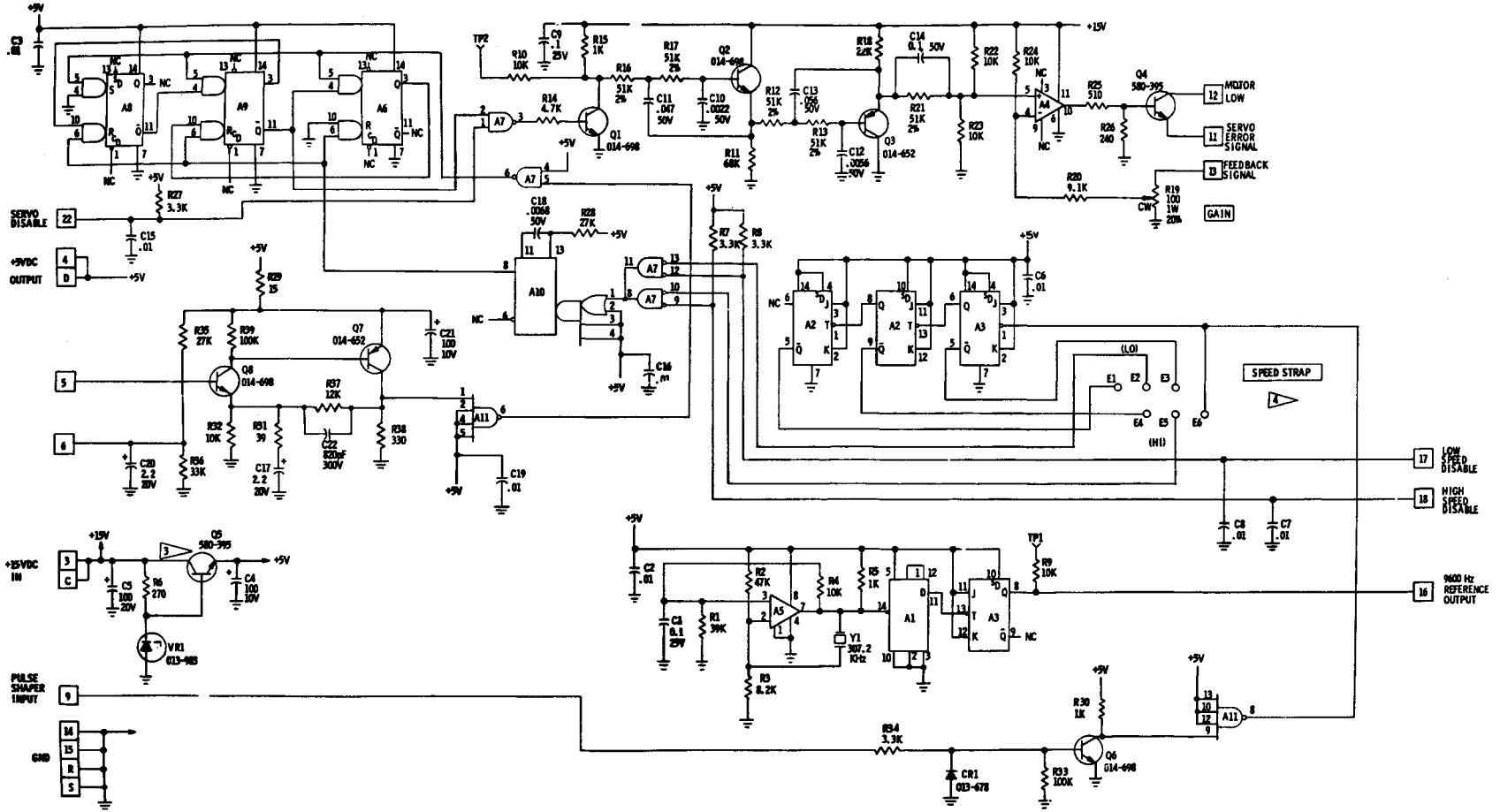

NOTES: UNLESS OTHERWISE SPECIFIED
 1. CAPACITANCE VALUES ARE IN MICROFARADS, 100V.
 2. RESISTANCE VALUES ARE IN OHMS 1/4W, 5%.
 HEATSINK REQUIRED.
 3. SEE TABLE 1 FOR SPEED STRAPPING.

FIELD SERVICE COMPONENT SUBSTITUTION LIST		
AMPEX PIN		NEAREST COMMERCIAL EQUIV.
013-332		1N750A
013-985		1N752A
014-452		2N2906
580-395		2N5190
014-498		NONE
015-678		1N5345

TABLE 1 SPEED STRAPPING				
RANGE	HI	MED	LOW	
HI	E5 TO E6	E5 TO E3	E5 TO E4	
LO	E2 TO E3	E2 TO E4	E2 TO E1	

REFERENCE DESIGNATION		I.C. LIST							
LAST USED	NOT USED	A11	A6, 8, 9	A7	A4	A1	A2, 3	A5	A30
A11 OR C22		586-680	586-690	586-153	586-268	586-280	586-425	587-086	586-300
B99		5N74131	6A 9950	MC 886P	UA 741C	5N7493N	MC 853P	LM-311N	LM 860L
C8									
TP2									
Q4									
VRL									
		VOLTAGE PIN	3A	3A	3A	11	5	1A	8
		GROUND PIN	7	7	7	6	30	7	4, 1