

AMPEX

4890301

AG-440B and AG-445B
Recorder and Reproducer

Operation and Maintenance Manual

AMPEX

4890301-03

CHANGE NOTICE

This change is to be collated into
manual no. 4890301-02
dated: JANUARY 1970 . Superseded
pages are to be destroyed.

AG-440 B / AG-445 B
Recorder / Reproducer
Operation and Maintenance Manual

ISSUED: FEBRUARY 1969

CHANGED: AUGUST 1971

LIST OF PAGES

PAGE NUMBER	CHANGE IN EFFECT	PAGE NUMBER	CHANGE IN EFFECT	PAGE NUMBER	CHANGE IN EFFECT	PAGE NUMBER	CHANGE IN EFFECT
Title	8/71	6-4B	8/71				
"A"	8/71	6-4C	8/71				
		6-4D	8/71				
i - xvi	1/70	6-4E/F	8/71				
		6-5	8/71				
Section 1		6-6	8/71				
8 pages		6-7	8/71				
		6-8	8/71				
Section 2		6-10	8/71				
8 pages		6-11	8/71				
		6-12	8/71				
2-5/6	1/70	6-13	1/70				
2-7/8	1/70	6-14	8/71				
		6-15	8/71				
Section 3		6-16	8/71				
6 pages		6-17	8/71				
		6-18	8/71				
Section 4		6-19	8/71				
54 pages		6-20	8/71				
		6-21	8/71				
4A-1	8/71	6-22	1/70				
4B-5	1/70	6-23	8/71				
4B-8	1/70	6-24	1/70				
4B-9/10	1/70	6-25	8/71				
4C-1	8/71	6-26	1/70				
4C-2	1/70	6-27	8/71				
4C-3	8/71	6-27A/B	8/71				
4C-4	8/71	6-28	1/70				
4C-5	8/71	6-29	8/71				
4C-11	1/70	6-30	8/71				
4C-12	1/70	6-31	1/70				
4E-2	8/71	6-32	8/71				
4E-3	8/71	6-33	1/70				
4E-4	8/71	6-34	8/71				
4F-1	1/70	6-35	8/71				
4F-2	1/70	6-36	8/71				
		6-37	8/71				
Section 5		6-38	8/71				
9 pages		6-39	8/71				
		6-40	8/71				
Section 6		6-41	8/71				
45 pages							
		Section 7					
6-1	8/71	16 pages					
6-2	8/71						
6-3	8/71	7B-1	8/71				
6-4	8/71	7B-2	8/71				
6-4A	8/71	7B-3	8/71				

NOTE: For listing of separable components and accessories, see pages 6-2, 6-3, 6-4, and 1-5.

ISSUE: August 1971



AG-440 Series Recorder/Reproducer (Frontispiece)

AMPEX

COMMUNICATING WITH AMPEX

SERVICE INFORMATION AND PARTS

FIELD ENGINEERING BULLETIN SERVICE (See note below)

Ampex provides a continuous technical support program for its products. This program is partially implemented through field engineering bulletins, which are published by the Ampex Technical Support Group. Approved modifications, information on special tools and accessories, and improved operating and maintenance techniques are typical of the information distributed in these bulletins.

If the installation of your system or accessory was supervised by an Ampex Field engineer, you will be sent these bulletins automatically. If this is not the case, contact the nearest Ampex field office or write to:

Ampex Corporation
Audio Technical Support Group
401 Broadway
Redwood City, California 94063 USA

SERVICE AND REPLACEMENT PARTS (See note below)

For service and replacement parts, contact your nearest Ampex field office. If the installation of your system or accessory was supervised by an Ampex field engineer, you will be sent information regarding the location of the nearest field office. Alternatively, write to the Technical Support Group at the address shown above.

NOTE

In order for the technical support program to function properly, the user must ensure that his communication is addressed to the proper department, and that it includes the following information, most of which can be obtained from the system identification nameplate on the equipment.

1. System name
2. Model number (including revision number)
3. System number
4. Serial number
5. Power requirements
6. System modifications and special accessories
7. Date of purchase
8. Name and address of your organization
9. Job function to which communication should be addressed
10. Physical location of equipment

COMMUNICATING WITH AMPEX

INSTRUCTION MANUAL CHANGES

Another part of the Ampex program of technical support for its products is the continuous revision and modification of instruction manuals as the equipment is improved or modified. In order to ensure that you always receive this information, write to:

Ampex Corporation
Audio/Video Technical Publications Department
401 Broadway
Redwood City, California 94063 USA

NOTE

In order to be sure that you always receive information applicable to your equipment, please include the following information when you write to us:

1. System name
2. Model number (including revision number)
3. Serial number
4. Power requirements
5. System modifications and special accessories
6. Approximate date of purchase
7. Name and address of your organization
8. Job function to which communication should be addressed

SAFETY & FIRST AID

Because personnel working with electronic equipment are exposed to the hazard of high voltage, it is imperative that all safety regulations be consistently observed, and that each individual has a clear understanding of basic First Aid methods.

The following typical hazards must be avoided at all times:

1 Do not attempt adjustment of unprotected circuit controls, or lead dress while the power is ON.

2 Do not change heavily loaded or overheated components without due precaution to avoid burns.

3 Do not assume that no dangerous voltage is present when the power is OFF. Charged capacitors may retain dangerous voltages for long periods, and should be discharged through a suitable resistor before any circuit points are touched.

4 At all times avoid placing any parts of the body in series between ground and circuit points, whether or not power is ON.

5 Do not assume that solid-state circuits and semiconductor cases carry only low voltages.

V08633

For their own protection, and the protection of others, all electronic personnel should become thoroughly familiar with the approved First Aid treatment of burns and shock. There are three principal degrees of burns, recognizable as follows:

1. A first degree burn reddens the skin
2. A second degree burn blisters the skin
3. A third degree burn chars the flesh and frequently places the victim in a state of shock accompanied by respiratory paralysis.

Respiratory paralysis in the victim can cause death within seconds, by suffocation. For this reason it is imperative that the approved method of artificial respiration be initiated immediately and continued until the victim's breathing is normal.

A muscular spasm or unconsciousness may render the victim unable to free himself of the electric power. If this is the case, turn the power OFF immediately.

CAUTION

DO NOT TOUCH HIM, OR YOU MAY SHARE HIS PREDICAMENT.

If the power cannot be turned OFF immediately, very carefully loop a dry rope, article of clothing, length of strong cloth, or a rolled-up newspaper around the victim and pull him free of the power. Carefully avoid touching him or his clothing.

The moment he is clear of the power, place him in a reclining position, cover him with a blanket (or newspapers) to keep him warm, and begin artificial respiration. At the first opportunity, enlist help in the summoning of a doctor. If a doctor cannot be summoned, transport the victim to the doctor, infirmary, or hospital. Be sure that the victim is kept well covered and warm while awaiting professional aid and treatment.

TABLE OF CONTENTS

<u>Paragraph</u>	<u>Title</u>	<u>Page</u>
Section 1.	DESCRIPTION	
1.1	General.	1-1
1.2	Tape Transport	1-1
1.3	Record/Reproduce Electronic Unit.	1-2
1.4	Reproduce Electronic Module	1-2
1.5	Head Assembly	1-4
1.6	Optional Equipment	1-4
1.7	Specifications	1-4
Section 2.	INSTALLATION	
2.1	Unpacking.	2-1
2.1.1	General	2-1
2.1.2	Console-Mounted Equipment.	2-1
2.1.3	Unmounted and Portable Equipment.	2-2
2.2	Mounting Units	2-2
2.3	Console Front Panel Removal.	2-2
2.4	Interconnecting Units.	2-2
2.5	Connecting Signal Lines	2-2
2.5.1	Connectors	2-2
2.5.2	Signal Input Connections.	2-2
2.5.3	Signal Output Connections	2-4
2.5.4	Restrapping Output	2-4
2.6	Connecting Power	2-4
2.7	Installing Accessories or Dummy Plugs	2-4
2.7.1	Input Transformer or Microphone Preamplifier	2-4
2.7.2	Remote Control Unit	2-4
2.7.3	Console Rear Covers	2-4
2.7.4	Scrape-Flutter Idler	2-5
2.8	Checking Cables and Components	2-5
2.9	Initial Lubrication	2-5
Section 3.	OPERATING INSTRUCTIONS	
3.1	Operating Controls and Indicators	3-1
3.1.1	Tape Transport	3-1
3.1.2	Record/Reproduce Electronic Unit	3-2
3.1.3	Reproduce Electronic Module	3-2
3.2	Pre-Operating Procedures	3-4
3.2.1	Applying Power	3-4
3.2.2	Selecting Tape Speed	3-4
3.2.3	Selecting Reel Hub Size	3-4
3.2.4	Threading Tape	3-4
3.2.5	Monitoring Facilities	3-4
3.3	Recording	3-4
3.3.1	Without Sel-Sync*	3-4
3.3.2	With Sel-Sync*	3-4
3.4	Reproducing.	3-5
3.5	Fast-Winding	3-5

* Registered, Ampex Corporation

3.6	Editing	3-6
Section 4.	MAINTENANCE	
4.1	Introduction	4-1
4.2	Contents	4-1
	PART A. CONVERSION	
4A.1	Turntable Repositioning	4A-1
4A.2	Tape-Width Conversion	4A-1
4A.2.1	General.	4A-1
4A.2.2	Rotating Tape Guides.	4A-1
4A.2.3	Changing Heads	4A-2
4A.2.4	Changing Head Cable Box.	4A-2
4A.3	Scrape-Flutter Idler Addition.	4A-2
4A.4	Channel Addition	4A-3
4A.4.1	General.	4A-3
4A.4.2	Record/Reproduce Unit Installation	4A-3
4A.4.3	Reproduce Module Installation.	4A-4
4A.5	Console Rear Cover Installation	4A-4
4A.6	Record and Reproduce Conversion	4A-4
	PART B. PREVENTIVE MAINTENANCE	
4B.1	Eighth-Hour Cleaning	4B-1
4B.1.1	Heads	4B-1
4B.1.2	Tape Guide Elements.	4B-1
4B.1.3	Scrape-Flutter Idler	4B-1
4B.2	Eighth-Hour Demagnetizing	4B-1
4B.3	Lubricating	4B-2
4B.3.1	General.	4B-2
4B.3.2	Drive Motor Initial Lubrication	4B-2
4B.3.3	Motor/Idler Three-Month Lubrication	4B-2
4B.3.4	Idler Yearly Lubrication	4B-3
4B.4	Performance Checkouts	4B-3
4B.4.1	General.	4B-3
4B.4.2	Test Equipment	4B-3
4B.4.3	Test Conditions	4B-4
4B.4.4	Frequency Response Checkout.	4B-4
4B.4.5	Overall Signal-to-Noise Check	4B-6
4B.4.6	Overall Distortion Check	4B-7
4B.4.7	Flutter Check	4B-7
	PART C. ADJUSTMENT AND ALIGNMENT	
4C.1	General	4C-1
4C.2	Tape Transport Adjustments	4C-1
4C.2.1	Test Equipment	4C-1
4C.2.2	Different Tape Sizes	4C-1
4C.2.3	Tape Tension	4C-1
4C.2.4	Brakes	4C-3
4C.2.5	Capstan Idler	4C-5
4C.2.6	Tape Lifter	4C-5

4C.3	Electronic Alignment	4C-6
4C.3.1	Standard Test Tapes	4C-6
4C.3.2	Test Equipment	4C-6
4C.3.3	Test Conditions	4C-7
4C.3.4	Alignment Procedures Introduction	4C-7
4C.3.5	Power Supply	4C-7
4C.3.6	Reproduce-Head Azimuth	4C-7
4C.3.7	Reproduce/Record Alignment	4C-8
4C.3.8	Record-Head Azimuth	4C-10
4C.3.9	Low-Frequency Reproduce Equalization	4C-11
4C.3.10	Record Equalization	4C-11
4C.4	Sel-Sync* Adjustments	4C-12
4C.4.1	Test Equipment	4C-12
4C.4.2	Test Conditions	4C-12
4C.4.3	Sel-Sync* Level Adjustment	4C-12
4C.4.4	Sel-Sync* Bias Trap Adjustment	4C-13

PART D. HEAD MAINTENANCE

4D.1	General	4D-1
4D.2	Adjusting Head Height	4D-1
4D.2.1	Record/Reproduce Heads	4D-1
4D.2.2	Quarter-Track Record/Reproduce Heads	4D-2
4D.2.3	Erase Heads	4D-2
4D.3	Adjusting Tape Wrap and Zenith	4D-2
4D.4	Changing Head Stacks	4D-2
4D.4.1	Record or Reproduce Stack	4D-2
4D.4.2	Erase Head Stack	4D-3
4D.5	Tape Skew Checkout	4D-3

PART E. TRANSPORT MAINTENANCE

4E.1	General	4E-1
4E.2	Servicing Units	4E-1
4E.2.1	Brake Bands	4E-1
4E.2.2	Solenoids	4E-1
4E.2.3	Relays	4E-1
4E.2.4	Capstan Idler	4E-2
4E.3	Head-Cable and Power-Supply Boxes Replacement	4E-2
4E.3.1	Head -Cable Box	4E-2
4E.3.2	Power Supply Removal	4E-2
4E.3.3	Power Supply Installation	4E-2
4E.4	Takeup and Rewind Assemblies	4E-2
4E.4.1	General	4E-2
4E.4.2	Replacing Takeup or Rewind Assembly	4E-2
4E.4.3	Reel Drive Plate Replacement	4E-3
4E.4.4	Turntable Pad Replacement	4E-3
4E.4.5	Brake Assembly Removal	4E-3
4E.4.6	Brake Band Replacement	4E-3
4E.4.7	Brake Solenoids Replacement	4E-3
4E.4.8	Brake Installation and Adjustment	4E-4
4E.4.9	Motor Capacitor Replacement	4E-4

* Registered, Ampex Corporation

4E.5	Drive Motor	4E-5
4E.5.1	Lubrication	4E-5
4E.5.2	Fan and Flywheel Replacement	4E-5
4E.5.3	Drive Motor Replacement	4E-5
4E.5.4	Motor Capacitor Replacement	4E-5
4E.6	Reel Idler	4E-5
4E.6.1	Tape Guide Replacement	4E-5
4E.6.2	Pulley Replacement	4E-5
4E.6.3	Idler Tension Adjustment	4E-6
4E.6.4	Arm Assembly Replacement	4E-6
4E.6.5	Reel Idler Replacement	4E-6
4E.6.6	Ball Bearing Replacement	4E-6
4E.7	Takeup Tension Arm	4E-7
4E.7.1	Arm Spring Adjustment	4E-7
4E.7.2	Safety Switch Adjustment	4E-7
4E.7.3	Tape Guide and Hook Replacement	4E-7
4E.7.4	Tension Spring Replacement	4E-7
4E.7.5	Takeup Tension Arm Replacement	4E-7
4E.8	Capstan Idler	4E-8
4E.8.1	Lubrication and Adjustment	4E-8
4E.8.2	Parts Not Removable	4E-8
4E.8.3	Idler Positioning	4E-8
4E.8.4	Idler Replacement	4E-8
4E.8.5	Capstan Solenoid Replacement	4E-8
4E.9	Tape Lifter	4E-9
4E.9.1	Adjustment Procedure	4E-9
4E.9.2	Solenoid Replacement	4E-9
4E.9.3	Tape Lifter Replacement	4E-10
4E.10	Safety Switch	4E-10
4E.11	Servicing Procedures	4E-10
4E.11.1	General	4E-10
4E.11.2	Control Box Bottom Cover Removal	4E-10
4E.11.3	Control Box Removal	4E-11
4E.11.4	Power Checks	4E-11
4E.11.5	Relay Actuation Check	4E-12
4E.11.6	Solenoid Actuation Check	4E-12
4E.11.7	Drive Motor Check	4E-15
4E.11.8	Takeup Motor Check	4E-15
4E.11.9	Rewind Motor Check	4E-16
4E.11.10	Power Lamp Replacement	4E-17
4E.11.11	Switch Replacement	4E-17
4E.11.12	Record Circuit Check	4E-17

PART F. ELECTRONIC CORRECTIVE MAINTENANCE

4F.1	General	4F-1
4F.2	Extender Boards Use	4F-1
4F.3	Input Power and Indicators Check	4F-1
4F.3.1	Recorder/Reproducer	4F-1
4F.3.2	Reproducer (only)	4F-2
4F.4	Record Relay Check	4F-2
4F.5	Power Supply Check	4F-3
4F.6	Bias Check	4F-3

4F.7	Record/Reproduce Check	4F-4
4F.7.1	General	4F-4
4F.7.2	Record Check	4F-4
4F.7.3	Reproduce Check	4F-4
4F.8	Reproduce Check	4F-4
4F.9	Parts Replacement	4F-5
4F.9.1	Indicator Lamps	4F-5
4F.9.2	Circuit Board Components	4F-5
4F.9.3	Other Components	4F-5
4F.10	Response Curve Check	4F-5
Section 5.	THEORY OF OPERATION	
5.1	Tape Transport	5-1
5.1.1	General	5-1
5.1.2	Tape Supply and Takeup Systems.	5-1
5.1.3	Tape Drive System	5-2
5.1.4	Reel Idler	5-2
5.1.5	Takeup Tension Arm	5-2
5.1.6	Tape Lifter	5-3
5.1.7	Control Circuit	5-3
5.1.8	Tape Scrape-Flutter	5-6
5.2	Electronic Circuits	5-6
5.2.1	Power Supply	5-6
5.2.2	Bias Oscillator and Amplifier Circuits	5-7
5.2.3	Record Amplifier Circuit	5-7
5.2.4	Reproduce Amplifier Circuit	5-8
5.2.5	Sel-Sync* Circuit	5-9
Section 6.	PARTS LISTS AND DRAWINGS (See List of Illustrations)	
6.1	Introduction	6-1
Section 7.	MODIFICATION PROCEDURES	
PART A. TAPE TRANSPORT MODE ALTERATIONS		
7A.1	General	7A-1
7A.2	Modification Procedures	7A-1
7A.2.1	Modification to Enter any Other Mode Directly from the Record Mode	7A-1
7A.2.2	Modification to Defeat all, or any, of the Edit Functions	7A-1
7A.2.3	Modification to Enter the PLAY/EDIT Mode by pressing the EDIT Pushbutton (when Tape is Stopped) Even When the Safety Switch is Open	7A-2
PART B. EXTERNAL MOTOR DRIVE AMPLIFIER ADDITION		
7B.1	General	7B-1
7B.2	Internal Wiring	7B-1
7B.3	Connecting Motor Drive Amplifier.	7B-2
7B.4	Preparing Dummy Plug	7B-2
PART C. SEL-SYNC* REMOTE CONTROL		
7C.1	Description	7C-1

* Registered, Ampex Corporation

7C.2	Switching Unit	7C-1
7C.2.1	General	7C-1
7C.2.2	Mounting	7C-1
7C.2.3	Connecting	7C-1
7C.3	Control Unit	7C-2
7C.3.1	General	7C-2
7C.3.2	Mounting	7C-2
7C.3.3	Connecting	7C-2
7C.4	Remote Operation	7C-2
7C.4.1	Recording	7C-2
7C.4.2	Reproducing	7C-3
7C.4.3	Fast-Winding	7C-4
7C.4.4	Edit Mode	7C-4
7C.5	Adjustments	7C-4
7C.5.1	General	7C-4
7C.5.2	Sel-Sync* Level Adjustment	7C-4
7C.5.3	Sel-Sync* Bias Trap Adjustment	7C-4

* Registered, Ampex Corporation

LIST OF ILLUSTRATIONS

<u>Figure</u>	TITLE	<u>Page</u>
Frontispiece	Ampex Model AG-440B Recorder/Reproducer.	i
1-1	Tape Transport	1-2
1-2	Record/Reproduce Unit	1-2
1-3	Printed Circuit Boards	1-4
1-4	Reproduce Electronic Module	1-4
2-1	Mounting Dimensions	2-2
2-2	Front Panel Mounting Details	2-2
2-3	Tape Transport Connector Panel.	2-3
2-4	Record/Reproduce Unit (Rear)	2-3
2-5	Record and Reproduce Modules	2-5
3-1	Controls and Indicators.	3-3
3-2	Tape Threading Path	3-3
4A-1	Head Assembly (Overlay Removed)	4A-2
4A-2	Head Cable Box	4A-2
4A-3	Scrape-Flutter Idlers Installed	4A-3
4A-4	Record/Reproduce Unit Supports	4A-4
4B-1	Noise Filter Schematic	4B-6
4B-2	ASA "A" -Curve Filter Schematic	4B-6
4C-1	Tape Tension Adjustments	4C-2
4C-2	Brake Adjustments	4C-3
4C-3	Capstan Idler Adjustment	4C-4
4C-4	Capstan Idler Force Measurement	4C-5
4C-5	Power Supply Box Interior	4C-7
4C-6	Head Azimuth Adjustments	4C-8
4D-1	Head Height and Zenith Adjustments	4D-2
4F-1	Record Response Check Setup.	4F-6
4F-2	Reproduce Response Check Setup	4F-6
5-1	Tape Transport	5-2
5-2	Block Diagram	5-6

LIST OF ILLUSTRATIONS (Continued)

<u>Figure</u>	<u>TITLE</u>	<u>Page</u>
5-3	Strapping Circuit, Simplified.	5-9
6-1	Head Assembly, Record/Reproduce, 1/4-inch Tape	6-5
6-2	Head Assembly, Reproduce-only, 1/4-inch Tape	6-6
6-3	Head Assembly, Record/Reproduce, 1/2-inch Tape	6-7
6-4	Head Assembly, Reproduce-only, 1/2-inch Tape	6-8
6-5	Head Connector Assembly	6-9
6-6	Head Cable Box Assembly	6-10
6-7	Scrape-Flutter Idler Assembly	6-11
6-8	Tape Transport Assembly, Front.	6-13
6-9	Tape Transport Assembly, Rear	6-13
6-10	Tape Transport Adjustments	6-14
6-11	Tape Lifter Assembly	6-15
6-12	Takeup Assembly	6-16
6-13	Rewind Assembly	6-17
6-14	Brake Assembly	6-18
6-15	Reel Idler Assembly	6-19
6-16	Drive Motor Assembly	6-20
6-17	Control Box Assembly, Top	6-21
6-18	Control Box Assembly, Inner	6-22
6-19	Printed Wiring Assembly, Record & Tape Lift Delay	6-23
6-20	Tape Transport Schematic	6-25
6-21	Transport Power Supply Diagram.	6-26
6-22	Power Supply Schematic, Record/Reproduce.	6-27
6-23	Power Supply Schematic, Reproduce-only	6-28
6-24A	Electronics Schematic, Record/Reproduce, Sheet 1	6-30
6-24B	Electronics Schematic, Record/Reproduce, Sheet 2	6-31
6-25	Electronics Schematic, Reproduce-only	6-35
6-26	Rear Panel, Electronics	6-36
6-27	Front Panel, Electronics	6-37
6-28	Right Hand Panel, Electronics	6-38

LIST OF ILLUSTRATIONS (Continued)

<u>Figure</u>	<u>TITLE</u>	<u>Page</u>
6-29	Capacitor Mounting Bracket, Electronics	6-39
6-30	Optional Remote Control	6-40
6-31	Optional Microphone Preamplifier	6-41
6-32	Response Curves, Sheet 1	6-42
6-33	Response Curves, Sheet 2	6-43
6-34	Cable, Electronics	6-44
6-35	Cable, Power.	6-45

LIST OF TABLES

<u>Table</u>	<u>TITLE</u>	<u>Page</u>
1-1.	Accessories	1-5
1-2.	Specifications	1-6
4B-1.	Record Level Setting	4B-5
4B-2.	Reproduce Signal/Noise from Peak Record Level	4B-8
4B-3.	Rotational Rates	4B-9
4C-1.	Tension Adjustments	4C-3
4C-2.	Main Brake Force	4C-3
4C-3.	Capstan Idler Force	4C-6
4C-4.	Standard Alignment Tapes	4C-7
4C-5.	Reproduce Equalization Level	4C-9
4C-6.	Record Equalization Level	4C-12

SECTION I

DESCRIPTION

Section 1

DESCRIPTION

1.1 GENERAL

Ampex Model AG-440B and AG-445B Magnetic Tape Recorders and Reproducers (frontispiece) have a very-quiet tape transport usable with 1/4-inch or 1/2-inch tape, and have solid-state plug-in electronic modules. Up to two channels can be used with 1/4-inch tape, and up to four with 1/2-inch tape. The AG-440B is a record/reproduce machine, and the AG-445B is a reproduce (only) machine. Part numbers and details of the different configurations of the AG-440B and AG-445B are given in the first tables in Section 6.

The tape transport, designed for very quiet mechanical action, consists mostly of sub-assemblies which may be removed without unsoldering connections. Heads plug into receptacles inside the head housing for easy removal and installation. Most relays and electronic circuits are also the plug-in type.

The AG-440B tape recorder/reproducer is available either mounted in an Ampex console (frontispiece), mounted in portable cases, or unmounted for vertical or horizontal installation in

a rack or custom console. The basic system consists of a tape transport, a head assembly, and one record/reproduce electronic unit for each channel. Each record/reproduce unit contains a built-in Sel-Sync* circuit for recording added channels in perfect synchronization with previously recorded channels. Plug-in accessories, such as a microphone preamplifier, a balanced line-input transformer, and a remote control unit are available as optional equipment.

The AG-445B reproducer is available either in a console or unmounted for installation in a rack or custom console. Up to four reproduce electronic modules will fit in the supplied mounting tray.

1.2 TAPE TRANSPORT (Figure 1-1)

A rigid-casting base is used to mount all components of the tape transport to assure precision machine-handling of the tape. Mechanical features allow the changing from one tape width to the other in a few minutes.

Two standard tape speed pairs are available: 3-3/4 or 7-1/2 inches per second (ips)

* TM Ampex Corp.

and 7-1/2 or 15 ips. Speed selection is made by a toggle switch, and electronic equalization is automatically switched according to the speed selected.

The transport, as delivered, will accommodate tape reels 10-1/2 inches, 8 inches, 7 inches, and 5 inches in diameter. Any combination of large NAB reel and small EIA reel may be used by setting the REEL (takeup tension) switches accordingly. Also, the turntables can be easily repositioned for use with a 11-1/2-inch CCIR reel.

Tape scrape-flutter is minimized by a scrape-flutter idler mounted (on jeweled bearings) between the record and reproduce head stacks. An optional second idler may be mounted to the left of the record head.

Two solenoid-actuated arms automatically move the tape from contact with the heads during the fast forward or rewind modes. For editing and cueing operations, electronic override of the tape lifter is provided by pressing the EDIT pushbutton.

A plug-in printed circuit card, containing the power supply and master-bias-and-erase oscillator, is mounted in a power supply box on the back of the tape transport. On the AG-455 reproducer, the bias oscillator is omitted.

Pushbutton controls at the transport lower right edge, select operation modes: RECORD, PLAY, REWIND, FAST FWD, STOP, and EDIT. These switches are on the front of the tape transport control box. The control box has externally-mounted main fuses, cable receptacles for transport sub-assemblies, and plug-in relays for the play, rewind, fast forward, and edit functions. One control box receptacle must have the dummy plug installed when the remote control unit is not connected to it.

1.3 RECORD/REPRODUCE ELECTRONIC UNIT (Figure 1-2 and 1-3)

One record/reproduce electronic unit is required for each recorder/reproducer channel. The record/reproduce unit consists of an electronic chassis with three plug-in printed-circuit-board modules.

Front panel controls are: RECORD and REPRODUCE LEVEL, RECORD SELECTOR, and OUTPUT SELECTOR. Pilot lamps light to indicate that the associated channel is ready to record or is recording. A large VU meter monitors levels of the record, reproduce, and bias plug-in modules. The modules, removable through a front panel cutout, are guided to printed-circuit-board receptacles when inserted in the chassis.

The three removable modules provide amplification for record, reproduce, and bias. The record and reproduce modules each contain an equalization printed-circuit-board receptacle that is mounted at right angles to the mainboards, so the board alignment controls are accessible at the module face. Equalization is automatically switched (according to the tape speed selected) by a solid-state switching circuit.

Receptacles for interconnect cables, accessories, and input/output-signal cables are on the back panel of the chassis. The panel also has a line-termination switch (to select correct termination during maintenance procedures), two alignment adjustments for the Sel-Sync electronics, a plug-in record relay, and a power fuse. A supplied dummy plug is inserted in the INPUT ACCESS(ory) socket (on the back panel) during shipment and when an unbalanced-line input is used. A supplied bridging transformer is inserted in the socket for a balanced-line input (input impedance with the transformer is 20,000 ohms).

Internal strapping provides either a +8 dBm, or +4 dBm, nominal output level into a 600-ohm line. The equipment is strapped for a +8 dBm output, which can easily be changed when desired.

1.4 REPRODUCE ELECTRONIC MODULE (Figure 1-4)

The AG-445 reproducer chassis can hold up to four reproduce electronic modules in its 3 1/2-inch high tray. The tray can be mounted in a 19-inch rack, or in a console.

The plug-in reproduce-and-equalizer printed circuit board in the reproduce module is the same as the one in the record/reproduce unit. Each module contains the complete circuitry for one reproduce channel. Any additional components must be mounted on a separate chassis.

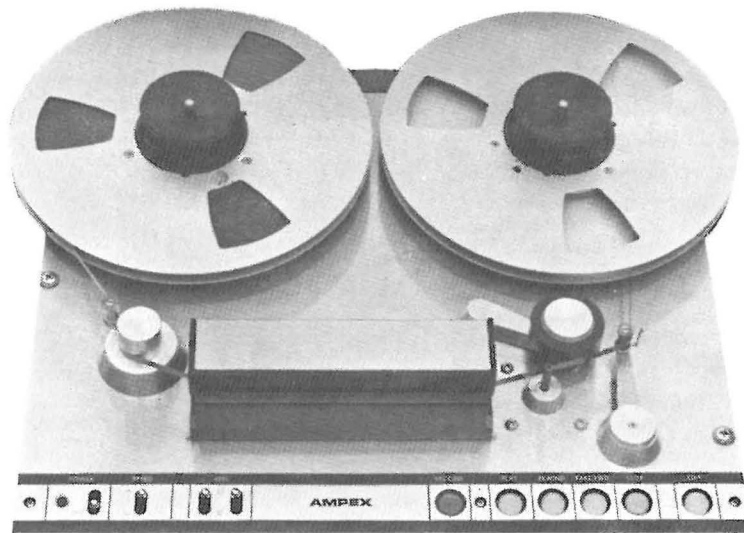

Fig. 1-1 Tape Transport

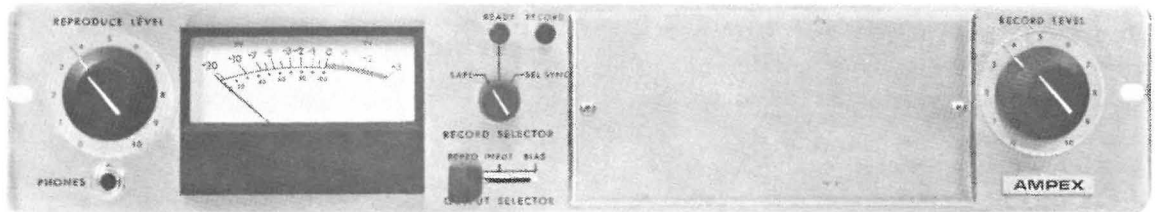

Fig. 1-2. Record/Reproduce Unit

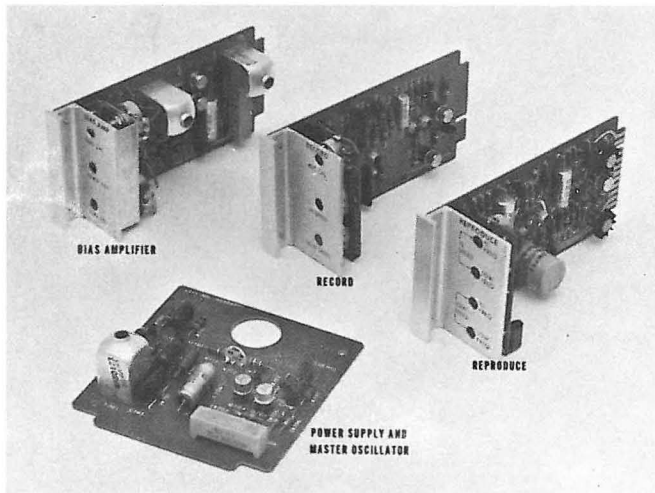

Fig. 1-3. Printed Circuit Boards

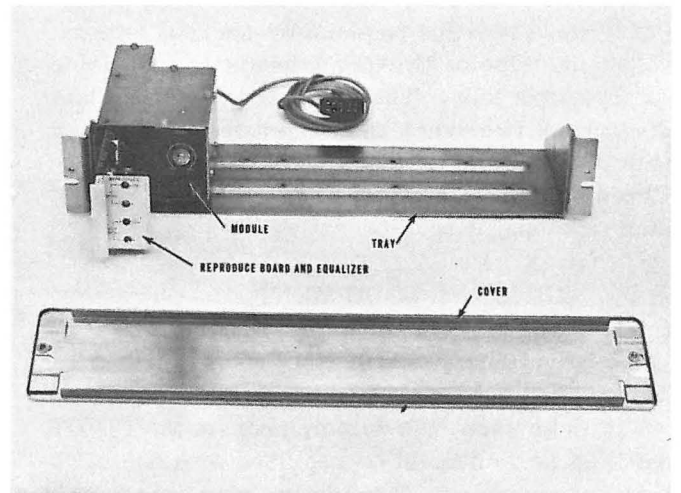

Fig. 1-4. Reproduce Electronic Module

A screwdriver-slot reproduce-level control is on the front panel of each module. The back panel contains the reproduce-head input receptacle, the line-output receptacle, a monitor jack, a line-termination switch (for use during maintenance), and a captive power-cable for connection to the transport power supply box.

1.5 HEAD ASSEMBLY

Although the erase, record, and reproduce head stacks are usually mounted in head-mounting positions 1, 3, and 4, respectively, many other combinations are possible.

For operation with 1/4-inch magnetic tape, a full-track head or a two-track head (for single-channel half-track operation) is available. A special four-stack head is also available which provides two-track erase, two-track record, quarter-track reproduce, and two-track reproduce, with a switch to select either the quarter-track or two-track reproduce head.

For 1/2-inch magnetic tape, three-track or four-track heads are available and are mounted in the normal head positions (1, 3, and 4).

Complete head assemblies can easily be changed to convert from a three or four-channel recorder using 1/2-inch tape, to a one or two-channel recorder using 1/4-inch tape.

Since the AG-445 reproducers contain only reproduce heads, a post is substituted in the erase-head position to maintain correct tape alignment. One or two-track heads are available for 1/4-inch tape. The two-track assembly has the normal two-track head and a 1/4-track head, with a switch for selecting the head desired. Three or four-track heads are available for 1/2-inch tape operation.

1.6 OPTIONAL EQUIPMENT

Available optional equipment is listed in Table 1-1. If a balanced-line or microphone input is to be used, the dummy plug (in the INPUT ACCESS socket) must be replaced with one of these accessories: 1) bridging-input transformer (providing unity gain with an input of 20,000 ohms), 2) matching input transformer (providing a gain of approximately 14 dB) and 3) microphone pre-

amplifier (for recording with a microphone). The preamplifier is a two-stage solid-state unit that is wired so the RECORD LEVEL control is connected between the two stages, making it a variable-gain device usable with a wide range of microphones.

1.7 SPECIFICATIONS

Specifications for significant parameters and features of the AG-440B Recorder/Reproducer and AG-445B Recorder are given in Table 1-2.

TABLE 1-1
ACCESSORIES*

DESCRIPTION	Ampex Part No.
Microphone Preamplifier	4010066
Remote Control Unit	4010080
Matching Transformer (600 ohms input impedance)	4580200-02
Console Rear Cover	4040982
Electronics Assembly Cover	4040984
Console Rear Cover Set	4010076-01 (contains 4040982 and 4040984)
	4010076-02 (contains 4040982 and two 4040984)
	4010076-03 (contains 4040982 and three 4040984)
	4010076-04 (contains 4040982 and four 4040984)
Scrape-Flutter Idler (not interchangeable with furnished idler)	4010069
Extender Boards for Circuit Boards:	
Reproduce	4020151
Record	4020152
Bias Amplifier	4020153
Power Supply	4020154
CCIR Record-Equalizer Module (For Conversion to CCIR recording)	4020269-03
Portable Case (for two electronic units)	4150330-02
(for 3-4 electronic units)	4150331
Blank Panel (for unused case spaces)	4290620-01
Support, Electronic Unit (used in pairs)	4260404
Reel, 10 1/2", 1/4" Tape (identical to reel supplied)	4690003-10
Reel, 10 1/2", 1/2" Tape	4690003-20
* Supplied with all required installation hardware.	

TABLE 1-2
SPECIFICATIONS

PARAMETER/FEATURE	DESCRIPTION
<u>Tape Width and Channels</u>	1/4-inch Tape -- 2 Channels max. 1/2-inch Tape -- 4 Channels max.
<u>Tape Speeds</u>	3-3/4 and 7-1/2 ips; or 7-1/2 and 15 ips
<u>Reel Size</u>	5-inch, 7-inch, 10-1/2-inch, EIA or NAB. Can accept 11-1/2-inch CCIR reel with adaptors. (Turntable reel switches provide correct tension for large or small reel hubs.)
<u>Input</u>	100,000 ohms unbalanced; convertible to 20,000 ohms balanced, with supplied bridging transformer. Accepts line levels from -17 dBm, to produce recommended operating level.
<u>Output</u>	600 ohms balanced or unbalanced, with nominal output levels of +4 dBm or +8 dBm.
<u>Equalization</u>	Automatically switched by transport speed selector.
<u>Electronics</u>	All Solid-state. Plug-in printed circuit boards for record, reproduce, and bias amplifiers. Built-in Sel Sync ** (selective synchronization) circuit. Power supply-and-bias oscillator for AG-440B; power supply, only, for AG445B (on separate plug-in printed circuit board in tape transport power supply box).
<u>Overall Frequency Response</u> *	15 ips NAB: ± 2 dB, 30 Hz to 18,000 Hz 7-1/2 ips NAB: ± 2 dB, 40 Hz to 15,000 Hz 3-3/4 ips: ± 2 dB, 50 Hz to 7,500 Hz
<u>Signal-to-Noise Ratio*</u>	Measured from peak record level (6 dB above Ampex operating level) to unweighted noise; while erasing a 500 Hz signal recorded at peak record level, with a filter to attenuate noise outside the audio spectrum.

<u>Tape Speed</u>	<u>Full-Track</u>	<u>Half-Track, or 2-Track</u>	<u>3-Track</u>	<u>4-Track</u>
15 ips NAB	66 dB	60 dB	62 dB	60 dB
7-1/2 ips NAB	66 dB	60 dB	62 dB	60 dB
3-3/4 ips	63 dB	56 dB	-----	-----

* Using Series 404 low-noise tape, biased for maximum sensitivity at 15 mil wavelength.

** TM Ampex Corp.

Signal-to-Noise Ratio*

Measured on an ASA "A" weighted curve

<u>Tape Speed</u>	<u>Full-Track</u>	<u>Half-Track, or 2-Track</u>	<u>3-Track</u>	<u>4-Track</u>
15 ips NAB	70 dB	64 dB	65 dB	64 dB
7-1/2 ips NAB	70 dB	64 dB	65 dB	64 dB
3-3/4 ips (120 micro secs.)	65 dB	58 dB	-----	-----

Bias Oscillator-and-Power Supply

(In tape transport power supply box)

Nominal bias/erase frequency 150,000 Hz.

Tape Lifting

Tape automatically lifts from heads in fast forward or rewind modes. (Manual or electronic override available during local control; electronic override on remote control.)

Even-Order Distortion

Second harmonic distortion of a 500 Hz signal, recorded at peak level, is less than 0.2%.

Flutter and Wow

Measuring all wavelengths from 0.5 Hz to 200 Hz according to ASA Z57.1-1954.

At 15 ips:	Maximum 0.08% rms
7-1/2 ips:	Maximum 0.1% rms
3-3/4 ips:	Maximum 0.15% rms

Start Time

Attains speed in 0.1 second; stable tape motion within 3.5 seconds (motion within Flutter and Wow specification).

Tape Recommended

Specifications are based on use of Ampex Series 404, Low-Noise Tape (or equivalent).

Speed AccuracyWithin $\pm 0.2\%$.Rewind Time

1 minute (approx.) for 2400-foot NAB reel.

Electronic Overload Margin

Record Amplifier: record level (before clipping) is 28 dB or more above normal operating level. Distortion is less than 1%, up to the clip level.

Reproduce Amplifier: output level (before clipping) is +28 dBm, which is +20 dB above normal operating level.

* Using Series 404 low-noise tape, biased for maximum sensitivity at 15 mil wavelength.

Operating Controls

Input and output-level rotary controls.

Record selector: "Safe", "Ready", and "Sel-Sync" positions.

Output and Meter Selector: "Reproduce", "Input", and "Bias" positions.

Toggle switches: Power, Tape Speed, and Reel (2).

Mode Control Pushbuttons: Play, Fast Forward, Rewind, Record, Stop, and Edit. (Edit modes available are Stop/Edit, Play/Edit, and Fastwinding/Edit. All modes except Stop/Edit and Play/Edit can be remotely controlled.)

Power Requirement

105-125 vac, 60 Hz (50 Hz system available).

Power Consumption

Systems:	Amps (Approx.);
1 channel:	2.3
2 channel:	2.5
3 channel:	2.7
4 channel:	2.9

SECTION II

INSTALLATION

Section 2

INSTALLATION

2.1 UNPACKING

2.1.1 General

Examine equipment for any sign of damage and check the packing list to determine that all items have been received. Immediately report any damage or shortage to the Ampex distributor and the transportation company.

NOTE

Plug-in electronic modules, and associated equalizer circuits, are shipped mounted behind a cover on the front panel of the electronic assemblies. The power supply and bias oscillator board is mounted in the power supply box in back of the tape transport.

Remove all materials (adhesive tape, rubber bands, etc.) used to secure tape-handling and other moving components during shipment.

2.1.2 Console-Mounted Equipment

Equipment ordered with the console is shipped mounted in the console with interconnections completed. The console is shipped lying on its back, with the tape transport rotated 90° to the horizontal position. Open the shipping container completely. Assure that the casters are fully inserted (to avoid bending their shafts when the recorder is tilted upright). Place a board in position to block the casters, then grasp the console vertical-support channels, between the electronic housing and the tape transport.

port, and tilt the console up and forward until it rests on the four casters. Manually stabilize the transport, then loosen the knurled knob on the left inner side of the console base, and rotate the transport to the horizontal position. Retighten the knob to secure the transport in position.

2.1.3 Unmounted and Portable Equipment

Equipment which is unmounted, or is mounted in portable cases, is shipped packaged separately. Use special care in unpacking unmounted equipment to prevent damage, especially to critical components, such as the capstan, head assembly and takeup tension arm.

2.2 MOUNTING UNITS (See Figure 2-1)

Equipment ordered with the console, or with portable cases, is mounted in position at the factory. Unmounted equipment can be mounted in a standard 19-inch rack, or in a custom cabinet. Mounting dimensions are given in Fig. 2-1. Insure that adequate ventilation space is provided between units.

2.3 CONSOLE FRONT PANEL REMOVAL (See Figure 2-2)

The console has a front panel (extending down and around the bottom of the control panel) which must be removed to perform some installation procedures. The panel has a duct portion around the drive motor fan. To remove the panel, release the two captive thumbscrews at the far corners (under the transport). Press up on the angled portion of the panel, to remove the cover lip from the transport frame slot. Move the panel clear of the transport frame, then lower it until the duct clears the fan.

To replace the panel, position the duct around the drive motor fan, insert the panel lip in the transport slot, press the lip firmly into position, then engage and tighten the two captive thumbscrews.

2.4 INTERCONNECTING UNITS (See Figure 2-3 and 2-4)

Equipment in a console is interconnected at the factory, however always insure that cable connectors are firmly seated and cables are undamaged. Portable equipment connections must

be made each time the recorder is set up in the field. Always route power and control cables as far as possible from the input-output cables and the head cables to avoid electrical interference.

Open the rear covers for access, and then make the following connections:

a. The power-and-control cable(s) from any tape transport POWER TO ELECTRONICS receptacle J701 through J704 to record/reproduce unit receptacle J11 (the four transport receptacles are connected in parallel, so any one may be used). On reproduce/modules, mate the power cable (captive) to any transport J701 through J704 receptacle.

b. Head cables (captive) to the corresponding receptacles (record, erase, reproduce) on electronic units. On multi-channel equipment, the head cables are marked with the track number, with the outermost track designated as track 1. Head cables for reproduce units have a three-pin connector; record head cables, a two-pin connector; and erase, a one-pin connector.

2.5 CONNECTING SIGNAL LINES (See Figure 2-4)

2.5.1 Connectors

The signal connectors, on the rear panel of the electronic units, are standard XL receptacles. Mate the supplied connectors with them.

2.5.2 Signal Input Connections

Connect two-conductor shielded cables to the line input, by wiring the signal leads to pin 3 and pin 2 (ground), and the shield to pin 1. With this connection, 1) the supplied dummy plug provides an unbalanced-line input, 2) either of the accessory plug-in transformers provides a balanced-line input, and 3) the accessory microphone preamplifier provides a microphone input. These units are connected at the input accessory receptacle on the back panel on the electronic units.

Connect single-conductor shielded lines with the conductor at pin 3 and the shield at pin 2 (applicable only to unbalanced-line inputs),

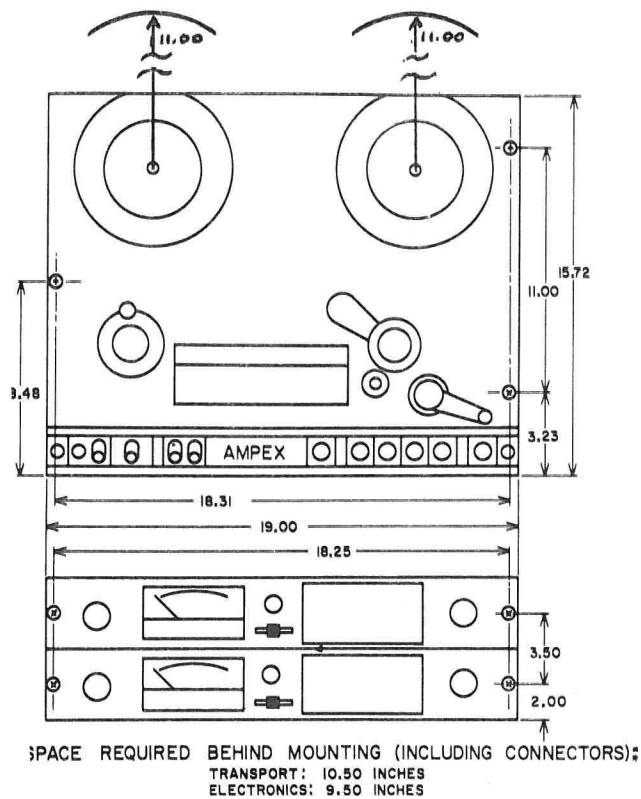

Fig. 2-1. Mounting Dimensions

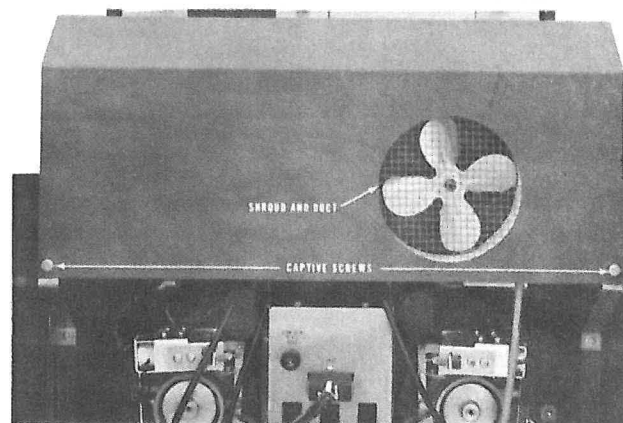

Fig. 2-2. Front Panel Mounting Details

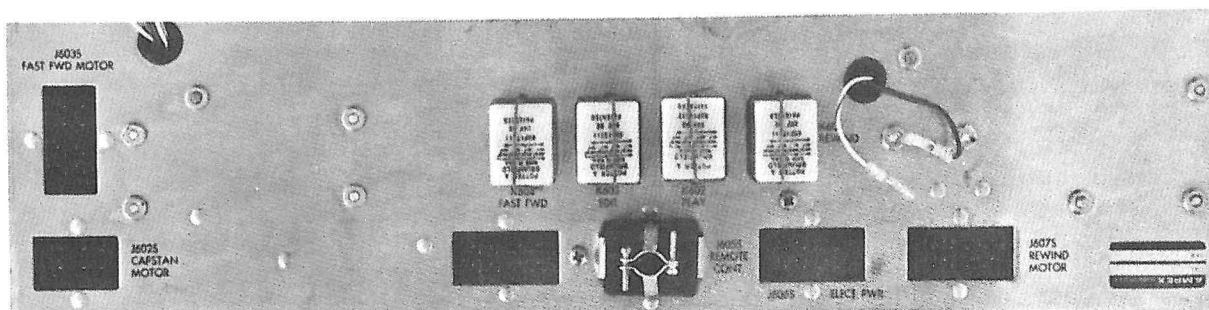

Fig. 2-3. Tape Transport Connector Panel

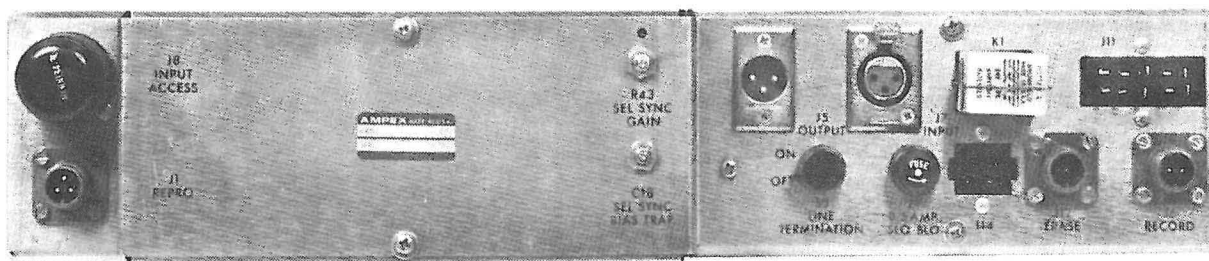

Fig. 2-4. Record/Reproduce Unit (Rear)

and insert the dummy plug in the INPUT ACCESS receptacle.

2.5.3 Signal Output Connections

An unbalanced-line output, requires a two-conductor shielded cable, with the signal leads wired to pin 3 and pin 2 (ground), the shield wired to pin 1, and a jumper from pin 1 to pin 2. A balanced-line output requires the same connections with the jumper omitted. For a single-conductor shielded cable (unbalanced line only) wire the conductor to pin 3, the shield to pin 2, and the jumper to pins 1 and 2.

The two-position LINE TERMINATION switch (see Figure 2-4), is usually at OFF, except during test or adjustment procedures. However, if the equipment is to be used to drive a high-impedance load (2,000 ohms or more), the switch must be in the ON position.

2.5.4 Restrapping Output (See Figure 6-28)

Record/reproduce units are delivered with the output strapped to provide a +8 dBm operating-level output into a 600-ohm line. If a +4 dBm operating-level output is required, the circuit can easily be restrapped as follows:

Step 1: Remove the top cover from electronic unit.

Step 2: On the right panel, terminal strip TB3 (toward the back of the assembly) has a jumper wire between terminals 2 and 3. Disconnect the jumper end from terminal 3, and reconnect it to terminal 1.

Step 3: If the operating level output is affected, recalibrate the record, reproduce, and bias levels according to paragraph 4C.3.7.

NOTE

The AG-445 reproducer has no optional strapping. The output is adjusted to the desired level by means of the LEVEL control.

2.6 CONNECTING POWER

Connect the power cable from AC POWER receptacle J601S, on the tape transport control box, to the power source.

2.7 INSTALLING ACCESSORIES OR DUMMY PLUGS (See Figure 2-4)

2.7.1 Input Transformer or Microphone Preamplifier

The equipment is shipped with a dummy plug (Catalog No. 4030034-30) in the INPUT ACCESS receptacle on the back panel of each record/reproduce unit. This plug provides correct input for an unbalanced line with input impedance 100,000 ohms. For a balanced-line input, remove the dummy plug and insert the bridging input transformer in the accessory socket; input impedance with the transformer is 20,000 ohms. For a balanced-line input with the matching input transformer (Catalog No. 4580200-02), gain is approximately 14 dB and input impedance is 600 ohms.

To record from a microphone, the optional microphone preamplifier (Catalog No. 4010066) must be installed in the accessory socket.

2.7.2 Remote Control Unit

Except for the edit function, all modes can be controlled from a remote location by the optional Ampex remote control unit (Catalog No. 4010080). This unit is plugged into REMOTE CONTROL receptacle J605S on the tape transport control box.

The remote control can disconnect the automatic tape-lifting mechanism, so that cueing can be quickly accomplished in the fast-winding modes.

If remote control is not used, the dummy plug (provided with the equipment) must be inserted in J605S or the recorder will not operate.

2.7.3 Console Rear Covers (See Table 1-1)

Rear covers for console-mounted equipment consist of a cover for the console base and

individual covers for each electronic assembly. The optional rear covers are secured to the console back uprights by captive spring-loaded thumbscrews, which mate with threaded holes in the uprights.

2.7.4 Scrape-Flutter Idler

The optional second scrape-flutter idler (Catalog No. 4010069) is mounted between head positions 2 and 3. The optional idler is larger in diameter than the one normally supplied, so the idlers are not interchangeable. Install the optional idler per paragraph 4A.3.

2.8 CHECKING CABLES AND COMPONENTS

Check and secure the following connections, components, and plug-in assemblies that could vibrate loose during shipment:

- a. Captive cable from takeup motor to receptacle J603S on the tape transport control box.
- b. Captive cable from rewind motor to receptacle J607S on the tape transport control box.
- c. Captive cable from capstan drive motor to J602S on the tape transport control box.
- d. Captive cable from electronic power supply box on the tape transport to J606S on the tape transport control box.
- e. The record/reproduce unit plug-in printed circuit boards. Especially check that the bias amplifier board, the record board, and the reproduce board are firmly in position.
- f. Reproduce modules (mounted in tray behind a solid-front cover secured by captive thumbscrews). Especially check printed-circuit board in each module.
- g. Equalizer circuit boards at the forward end of the record and reproduce modules (see Figure 2-5).
- h. Fuses: two on the tape transport control box, one on the tape transport power supply box, and one on the rear panel of each record/reproduce unit or reproduce module; also check that fuses are intact.

- i. Plug-in relays, four on the tape transport control box, and one on each record/reproduce unit back panel.

- j. Circuit board for power supply and-bias oscillator (power supply only, on the AG-445 reproducer) in the power supply box on the back of the tape transport.

2.9 INITIAL LUBRICATION

Before operating the equipment, lubricate the drive motor according to paragraph 4B.3.2.

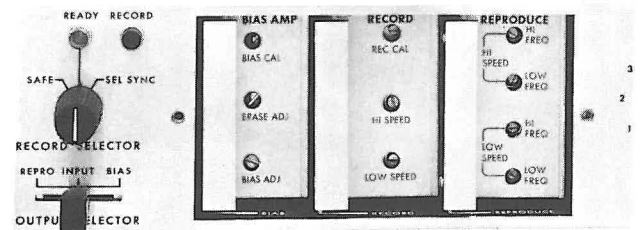

In Place

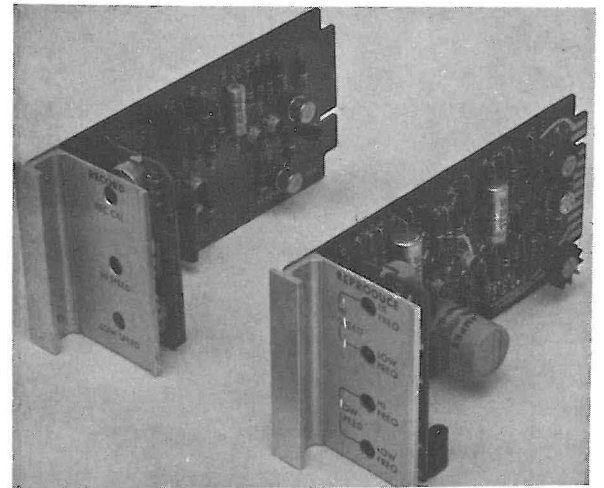

Removed

Fig. 2-5. Record and Reproduce Modules

INSTALLATION INSTRUCTIONS
FOR
REEL IDLER FLYWHEEL

SECTION 2 ADDENDUM

1.0 INTRODUCTION

The flywheel has been removed to prevent possible damage to bearings in shipment.

2.0 TOOLS

1. A 3/32 inch Allen wrench (with handle and long shaft).
2. Feeler gauge.

3.0 INSTALLATION PROCEDURE

1. If console unit, refer to Section 2, Page 2-2, Para. 2.3 (Console Front Panel Removal).
2. Proceed as follows:
 - a. Remove grommet from shaft of idler pulley.
 - b. Rotate pulley until pulley shaft flat is toward the outer edge of the rewind motor.
 - c. Hold flywheel to the shaft (setscrew side in).
 - d. Align setscrew to the flat and place flywheel on shaft. (End play must be 0.003-0.005 inch to avoid damaging the ball bearings.)
 - e. Check the end play by firmly holding the pulley down in the housing and checking with a feeler gauge between the pulley and the housing (at the side opposite the arm).
 - f. To this measurement add 0.004 inch and select feeler gauge leaves equal to the total.
 - g. Insert the gauge between the pulley and the housing, at the side opposite the idler arm.
 - h. Hold the pulley firmly down on the gauge and push the flywheel so that it firmly contacts the bottom of the housing.
 - i. Tighten the flywheel setscrew and remove the feeler gauge.

- 4.0 If console unit, refer back to Section 2, Page 2-2, Para. 2.3 to replace the front panel.

SECTION III

OPERATING INSTRUCTIONS

OPERATING INSTRUCTIONS**3.1 OPERATING CONTROLS AND INDICATORS****3.1.1 Tape Transport (see Fig. 3-1)**

POWER toggle switch	Controls application of power to entire equipment.
POWER indicator lamp (amber)	Lights when power is applied.
SPEED toggle switch	Selects slow (♣) or fast (♠) speed. (Equalization is automatically switched in accordance with speed selection.)
REEL toggle switches (2)	Used to select correct tension for large (O) or small (o) reel hubs. (One switch for each turntable.)
RECORD pushbutton	Sets the equipment in the record mode. (Tape motion must first be started by pushing the PLAY pushbutton with the RECORD SELECTOR at READY.)
EDIT pushbutton	Changes equipment to stop/edit or play/edit mode from, respectively, stop or reproduce (play) mode. Also overrides automatic tape lifter in the fast-winding modes, to provide fast-winding/edit mode.

REWIND pushbutton	Sets tape supply reel to the fast-winding mode. (Can be initiated from any mode except the record or play/edit modes.)
FAST FWD pushbutton	Sets tape takeup reel to the fast-winding mode. (Can be initiated from any mode except the record or play/edit mode.)
STOP pushbutton	Stops the equipment from any mode.
PLAY pushbutton	Sets equipment for the reproduce mode. (Must be pressed before the record mode can be initiated.)

3.1.2 Record/Reproduce Electronic Unit (see Fig. 3-1)

REPRODUCE LEVEL rotary control	Used to adjust reproduce level.
Meter	VU meter indicates reproduce, record or bias level, as selected at the OUTPUT SELECTOR switch. Meter lights when power is applied.
RECORD SELECTOR rotary switch	Selects one of three conditions: SAFE (Channel cannot be placed in the record mode.) READY (Channel can be placed in the record mode). SEL SYNC*(Channel will operate in the Sel Sync* condition, refer to paragraph 3.3.2).
PHONES	Output signal for headphone monitoring
Ready indicator light (amber)	Lights when RECORD SELECTOR is at READY; and remains lit while the channel is in the record mode.
Record indicator light (red)	Lights when the channel is in the record mode.
OUTPUT SELECTOR slider switch	Connects one of three signals as follows: REPRO: Signal reproduced from the tape is connected to monitor and output lines, and to the VU meter. INPUT: Signal to be recorded is connected to monitor and output lines, and to the VU meter. BIAS: Bias signal (record mode) is connected to VU meter.
RECORD LEVEL rotary control	Adjusts record level.

3.1.3 Reproduce Electronic Module

LEVEL screwdriver control	Adjusts reproduce level.
---------------------------	--------------------------

*TM Ampex Corp.

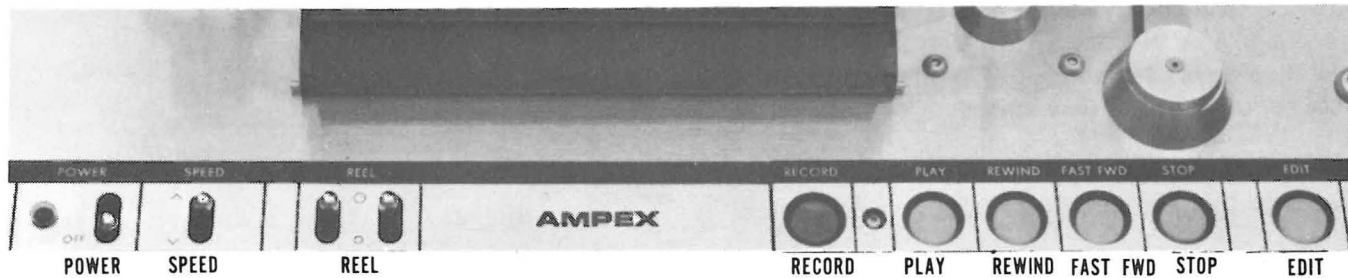

Tape Transport

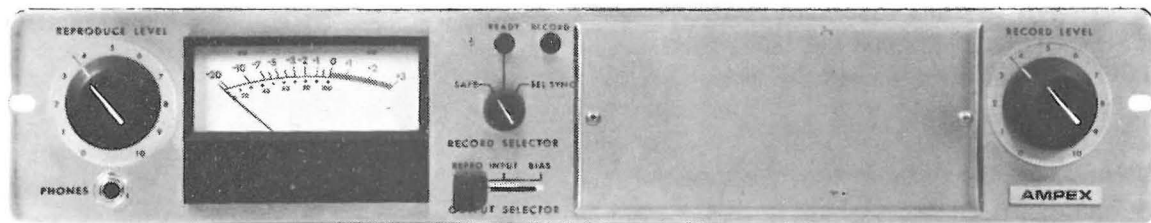

Record/Reproduce Unit

Fig. 3-1. Controls and Indicators

3.2 PRE-OPERATING PROCEDURES

3.2.1 Applying Power

Set tape transport POWER (toggle switch) to ON (on record/reproduce unit, POWER and VU meter lamps light).

3.2.2 Selecting Tape Speed

The two available tape transport speeds are 3-3/4 or 7-1/2 ips, and 7-1/2 or 15 ips. Low or high speed is selected by setting the SPEED toggle switch to ∇ (low speed) or \wedge (high speed).

Electronic equalization is automatically switched to conform to the tape speed selected.

3.2.3 Selecting Reel Hub Size

A REEL toggle switch for the supply reel, and one for the takeup reel are set to conform with the size of the hubs on the reels in use. For NAB hubs (4-1/2-inch diameter) the switch is set at O (large hub). For EIA hubs (2-1/4-inch diameter) the switch is set at o (small hub). A large hub may be used on one turntable and a small one on the other.

3.2.4 Threading Tape (see Figure 3-2)

To facilitate tape threading, apply power, turn tension arm until safety switch clicks, press EDIT pushbutton, then release the arm; this reduces the turntable braking force, so the reels can be easily hand-turned. Thread the tape, then press the STOP pushbutton to end the stop/edit mode.

Anchor the tape to the hub of the takeup reel, then hand-turn the takeup reel until the supply reel moves. This should remove all tape slack, and hold the takeup tension arm out of contact with the safety switch.

3.2.5 Monitoring Facilities

For audio monitoring, plug headsets (or an amplifier/speaker) into the record/reproduce unit PHONES jack (on the front panels).

3.3 RECORDING

3.3.1 Without Sel-Sync

Step 1: Switch POWER to ON.

Step 2: Thread blank tape on transport, then close head gate.

NOTE

Always bulk-erase any tape that was recorded on equipment with a different head configuration, to make sure that it is completely erased.

Step 3: At tape transport, set tape speed, and set REEL toggle switches for the size of reel hubs in use.

Step 4: Set record/reproduce unit RECORD SELECTOR to READY (READY indicator will light). For channels not to be recorded, set the RECORD SELECTOR at SAFE.

Step 5: Set OUTPUT SELECTOR to INPUT. Using a rehearsal-run or test signal, adjust RECORD LEVEL so the VU meter indicates "0" for most audio peaks (extreme peaks can indicate +2 or +3).

Step 6: Press PLAY pushbutton to start tape in motion, then press RECORD (channels set at READY then record, and the RECORD lamps light).

NOTE

During the record run, the input signal may be compared with the recorded signal by setting OUTPUT SELECTOR switch(es) alternately to INPUT and REPRO.

Step 7: Press STOP pushbutton (tape motion stops and record mode ends).

3.3.2 With Sel-Sync

The Sel-Sync circuitry of each record/reproduce unit allows initial recording, and then additional recording in synchronization with the recorded material on other channels.

Step 1: Make recording according to paragraph 3.3.1.

Step 2: Rewind tape to align heads with the tape location to start re-recording.

Step 3: On record/reproduce unit(s) which recorded the previous run(s), set RECORD SELECTOR switch(es) to SEL-SYNC.

Step 4: Set RECORD SELECTOR switch(es) on the recording record/reproduce units at READY and OUTPUT SELECTOR switch(es) at INPUT. Use a rehearsal-run or test signal to adjust RECORD LEVEL so the VU meter indicates "0" for most audio peaks (extreme peaks can indicate +2 or +3).

Step 5: Set OUTPUT SELECTOR on recording channels to REPRO.

Step 6: Place monitor headset on performer.

Step 7: Press PLAY, then RECORD pushbuttons (performer hears recording, so he can perform in synchronization with it).

Step 8: Press STOP pushbutton (tape motion stops and record mode ends).

Step 9: For each channel the performer is to monitor, set the corresponding RECORD SELECTOR at SEL-SYNC, and set all others at SAFE.

Step 10: Repeat procedure for each additional channel to be recorded.

3.4 REPRODUCING

Step 1: Switch POWER to ON.

Step 2: On all record/reproduce units, set RECORD SELECTOR at SAFE.

Step 3: Thread recorded tape on transport then close head gate. On two-channel equipment with the normal two-track head and a 1/4-track head, push the switching knob down-to select the two-track head, or up-to select the 1/4-track head.

Step 4: Select tape speed corresponding to speed at which tape was recorded. Set REEL toggle switch on each turntable for the size of the reel hubs in use.

Step 5: Set OUTPUT SELECTOR to REPRO on record/reproduce units (otherwise there will be no output).

Step 6: Press PLAY pushbutton (tape starts in the reproduce mode). Adjust REPRODUCE LEVEL as necessary (on reproduce modules the control is behind the mounting tray front cover).

Step 7: Press STOP pushbutton (if tape runs completely off the supply reel, operation will automatically stop).

3.5 FAST-WINDING

For tape editing or cueing, the tape is rapidly wound by pressing the REWIND or FAST FWD pushbuttons. The pushbuttons can be pressed alternately, without first stopping tape motion. When the desired tape area is reached, press the STOP pushbutton (if tape runs off either reel, operation will automatically stop). Either fast-winding mode can also be entered from the stop or play modes, but is locked-out when in the record, or play/edit mode (in play/edit the takeup tension arm doesn't hold the safety switch closed, thus fast-winding is locked-out).

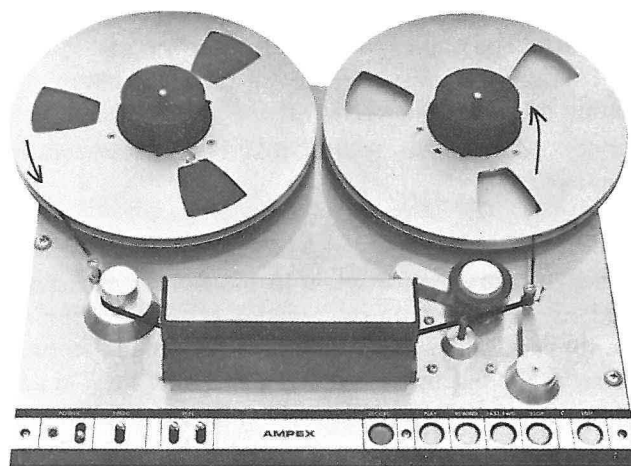

Fig. 3-2. Tape Threading Path

To enter other modes from the fast-winding modes, press the STOP pushbutton, then when tape motion stops, actuate the control for the mode selected.

CAUTION

Allow fast-winding tape motion to stop before pressing the PLAY pushbutton to avoid breaking or stretching the tape.

Two automatic tape-lifter arms (removing tape from head contact) are automatically actuated in both fast-winding modes. For fast-winding audio monitoring, the EDIT pushbutton is then pressed (this overrides the tape lifter). When manual override is desired, open the head gate and push the head-lifter post back.

3.6 EDITING

The three edit modes available are stop/edit, play/edit, and fast-winding edit.

The stop/edit mode can be initiated, with the tape stationary, by pressing the EDIT pushbutton. If the tape isn't threaded, the takeup-tension arm must be held away from the safety switch to reduce turntable braking force, so the reels can be easily rotated by hand. The stop/edit function facilitates manual cueing and threading of the tape. To end the stop/edit mode, press the STOP pushbutton.

The play/edit mode can be initiated from the reproduce mode by pressing the EDIT pushbutton. The tape continues in motion (speed controlled by the capstan) but the takeup turntable stops and the tape spills off the transport right side. This mode is used mainly to cut out unwanted tape.

Fast-winding/edit is entered by pushing the EDIT pushbutton when in the fast forward or rewind mode. This overrides the tape lifter so audio monitoring is possible. This mode is primarily for quickly reaching a desired tape area (for rough cueing).

SECTION IV

MAINTENANCE

Section 4
**MAINTENANCE
FOREWORD**

4.1 INTRODUCTION

This section is divided into the following six parts; and all data numbering includes the part designation as the second digit:

- A. Conversion
- B. Routine Maintenance
- C. Adjustment/Alignment
- D. Head Maintenance
- E. Transport Maintenance
- F. Electronics Maintenance

4.2 CONTENTS

Part A, CONVERSION, contains procedures such as repositioning turntables (for the large CCIR reels), converting to another tape width, adding optional accessories (such as the second tape scrape-flutter idler, and the console rear covers), adding more channels, and converting from a reproducer to a recorder-reproducer.

Part B, PREVENTIVE MAINTENANCE, including cleaning, demagnetizing, lubricating, and overall performance checkout.

Part C, ADJUSTMENT/ALIGNMENT, contains normal mechanical/electronic adjustment and adjustment procedures to correct faults indicated by the overall performance checks.

Parts D, E, and F contain corrective maintenance procedures for the magnetic heads, tape transport, and electronic assemblies respectively.

NOTE: Refer to the Table of Contents and Index Lists to find specific information.

Section 4

MAINTENANCE**Part A. Conversion****4A.1 TURNTABLE REPOSITIONING**

The takeup and rewind assemblies, including turntables, are secured to the reel guards through slotted holes (in the top plate) that permit adjustment to or from the transport center. When shipped, both assemblies are positioned as near as possible to the center; this position allows the use of reels up to 10-1/2 inches in diameter. When the turntables are positioned fully outward, transports cannot be mounted side-by-side on standard 19-inch racks, because the reels protrude over the rack edges.

For use with 11-1/2 inch CCIR reels both turntables can easily be repositioned as follows:

Step 1: At the back of the tape transport, loosen the three self-locking nuts (item 77, Fig. 6-9) which secure each assembly to the reel guard.

Step 2: Slide the takeup and rewind assemblies as far as possible from the center of the transport.

Step 3: Check that reel guard flats are parallel to transport top edge, and that turntables are centered in the guards, then tighten the nuts.

4A.2 TAPE-WIDTH CONVERSION**4A.2.1 General**

Changing between 1/2-inch and 1/4-inch magnetic tape is easily accomplished on the tape transport by rotating the two tape guides in their mountings. Changing channels between tape sizes or adding channels, may require changing of the head assembly or head cable box. The head azimuth adjustment and electronic alignment is required after any change of heads. The required procedures follow:

4A.2.2 Rotating Tape Guides

To rotate the two tape guides (on the reel idler and the takeup tension arm), lift the guides against the spring pressure and turn them until the correct-size guide is in the tape threading path. The guides snap down into position when correctly aligned. After tape width conversion, adjust tape tension (Table 4C-1).

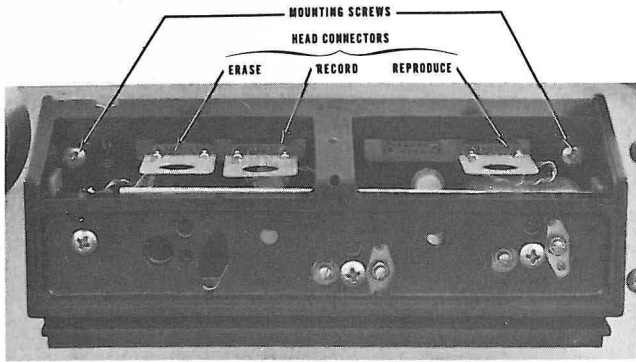

4A-1. Head Assembly (Overlay Removed)

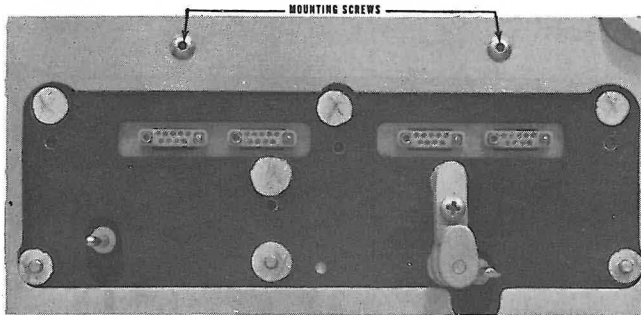

4A-2. Head Cable Box

4A.2.3 Changing Heads (See Figure 4A-1)

Remove the stainless-steel head cover by loosening the captive screw on the head slanted rear surface. On a four-position head, the switching knob (at the cover center) must be unscrewed to free the cover. Disconnect all head connectors, remove the two screws holding the head to the top plate, and (avoiding the bumping or scratching of the scrape-flutter idler) lift the head up and off. If the head cable box is to be changed, change it per paragraph 4A.2.4 before reinstalling the heads.

Clean the mounting surfaces on the tape transport and the head, then replace the assembly in the reverse order of removal procedures. Assure that head connectors are correctly mated as shown in Fig. 4A-1.

NOTE

Catalog numbers of the various head assemblies are listed in the parts lists, Section 6.

4A.2.4 Changing Head Cable Box (See Figure 4A-2)

The two conditions under which the head cable box must be changed are: 1) equipment is to have channels added; and 2) conversion to handle 1/4-inch tape (using the four-stack head) or re-conversion to handle 1/2-inch tape. To remove the head cable box for inspection (head removal is unnecessary) just remove the head overlay and disconnect the heads from the receptacles. Change the head cable box as follows:

Step 1: Remove the head assembly per paragraph 4A.2.3.

Step 2: Disconnect all head cables from receptacles.

Step 3: Manually support head cable box and remove the two screws immediately behind the head assembly. This frees the box and it can be removed.

Step 4: Replace the box in the reverse order to removal procedures.

NOTE

Catalog numbers of various head cable box configurations are given in Section 6.

4A.3 SCRAPE-FLUTTER IDLER ADDITION (See Figures 4A-2 and 4A-3).

The tape scrape-flutter idler kit (Catalog No. 4010069) contains the idler, a mounting screw, and a lockwasher. The furnished idler, with small roller (3/8 inch), is mounted between head position 3 and 4. The optional idler, with the large roller (15/32 inch), must be mounted between head positions 2 and 3. Install the optional idler as follows:

Step 1: Remove the head assembly per paragraph 4A.2.3.

Step 2: Mount the idler on the locating pin and boss and secure it with the screw and washer.

Step 3: Replace the head assembly.

Step 4: Check head azimuth and adjust as necessary per paragraphs 4C.3.6 and 4C.3.8.

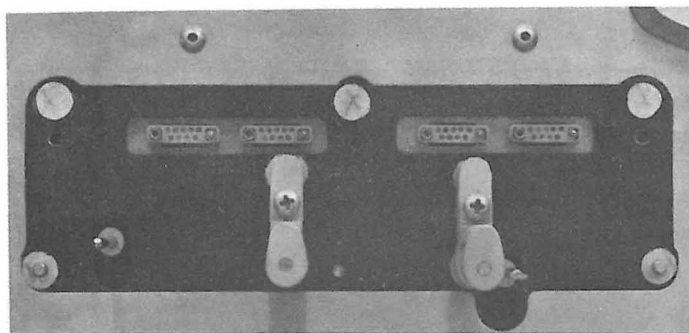

4A-3. Scrape-Flutter Idlers Installed



4A-4. Record/Reproduce Unit Supports

4A.4 CHANNEL ADDITION

4A.4.1 General

To add channels (up to a total of four), change the head per paragraph 4A.2.3, and the head cable box per paragraph 4A.2.4. Then add one record/reproduce unit for each added channel as follows:

4A.4.2 Record/Reproduce Unit Installation (See Table 1-2 and Figure 4A-4)

One interconnecting cable (Catalog No. 4050442) must be connected to each added record/reproduce unit. Optional plug-in input units such as the balanced-line transformer, microphone pre-amplifier, etc. (described in Section 1) may be added.

1. For mounting in racks, or in custom consoles, secure the record/reproduce unit in position next to the installed units. Mounting dimensions are shown in Fig. 2-1.

2. The two portable cases for the record/reproduce units are a two-unit case (Catalog No. 4150330) and a four-unit case (Catalog No. 4150331). Two two-unit cases may be used for three or four-channel portable systems; and stacked on top of each other during use. For one channel or three channel equipment, a blank panel (Catalog No. 4290620) is available for the space left empty. Each unit is secured in the case by two 12-24 x 3/4 oval-head Phillips screws, used with white nylon cup-washers.

3. Each additional record/reproduce unit mounted in an Ampex console requires two supports (Catalog No. 4260404) installed as follows:

Step 1: Remove the top cover over the installed record/reproduce unit(s), and remove the uppermost unit.

Step 2: Attach the new supports to the installed supports (one on each side) with the two supplied 6-32 x 5/8 pan-head screws, two flat washers, two lockwashers, and two 6-32 hex nuts.

Step 3: Replace the top cover and mount the record/reproduce units. Secure each assembly to the supports with two 12-24 x 3/4 oval-head Phillips screws, and two white nylon cup-washers.

Step 4: Connect the record/reproduce units to the tape transport according to paragraphs 2.4 through 2.7.

If the console is equipped with optional rear covers, individual covers (Catalog No. 4040984) should be ordered for each additional record/reproduce unit.

4A.4.3 Reproduce Module Installation

When adding a reproduce module to a system, an equalizer circuit board is also required. Catalog numbers of the equalizers and the module are given in the first tables of Section 6. The reproducer tray holds up to four modules, and may be rack-mounted or console mounted. Install the module as follows:

Step 1: Remove the plug-in reproduce board from the chassis.

Step 2: Remove the front cover of the reproducer tray.

Step 3: Slide the chassis into position in the tray, and secure it with three No. 6 self-tapping screws inserted up through the bottom of the tray.

Step 4: Mate the equalizer connector to the receptacle at the front of the reproduce board.

Step 5: Slide the reproduce board into the chassis on the guides until it mates with its receptacle.

Step 6: Connect the reproduce module to the tape transport according to paragraphs 2.4 through 2.7.

4A.5 CONSOLE REAR COVER INSTALLATION

The optional rear covers (see Table 1-2) are attached to the uprights by captive, spring-loaded, thumbscrews mating with threaded holes in the uprights.

4A.6 RECORD AND REPRODUCE CONVERSION

To convert between reproducer and record/reproduce units: 1) change the circuit board in the electronics power supply (record/reproduce equipment uses a card containing a power supply and a bias oscillator; the bias oscillator is omitted on the reproducer board), 2) change the head assembly and head cable box per paragraphs 4A.2.3 and 4A.2.4, and 3) add the electronic unit(s) per paragraph 4A.4.

NOTE

Catalog numbers of the power supply boards, heads, head cable box assemblies, and the electronics units are included in the first tables of Section 6.

Section 4

MAINTENANCE

Part B. Preventive Maintenance

4B.1 EIGHTH-HOUR CLEANING

4B.1-1 Heads

Clean heads, and all other components in the tape threading path, after each eight hours of operation, or oftener if visual inspection indicates the need. This is to remove the oxide (deposited from the magnetic tape) which will degrade equipment performance as it accumulates. Clean each head thoroughly with a cotton-tipped applicator dampened with Ampex Head Cleaner (Catalog Nos. 4010823 or 087-007).

CAUTION

When cleaning the heads, use only the recommended solvent, to avoid damaging the heads. Keep solvent off of plastic finishes and the capstan idler tire. Do not use metal tools which might scratch the heads.

4B.1-2 Tape Guide Elements

Use iso-propyl alcohol to clean all tape-guiding elements, the capstan, and the capstan idler.

CAUTION

Do not use head-cleaning solution on these components, it will damage the idler rubber tire and cause tape slippage if applied to the capstan.

4B.1-3 Scrape-Flutter Idler

Clean scrape-flutter idlers with a dry cotton-tipped applicator. Be sure to remove all oxide from the top and bottom of the roller holder assemblies.

4B.2 EIGHTH-HOUR DEMAGNETIZING

Heads and other components in the tape threading path can acquire permanent magnetization that increases signal noise and distortion,

and partially erases high frequencies on recorded tapes. Demagnetize components after each eight hours of operation, or oftener if required, using an Ampex Head Demagnetizer (Catalog No. 4010820), or equivalent, as follows:

Step 1: Turn equipment power off, and remove any recorded tape near the transport (tape could be partially erased by the demagnetizer).

Step 2: Cover the demagnetizer tips with pressure-sensitive tape (to prevent scratching the heads) and plug the demagnetizer into a 110-120 volt a-c power source.

Step 3: Simultaneously and lightly touch one demagnetizer tip to each face of one head.

Step 4: With a slow even motion, move the tips up and down the stack several times. Slowly withdraw the demagnetizer (slow withdrawal is required for effective demagnetization).

Step 5: Repeat Steps 3 and 4 at each head stack, tape guide (on the reel idler and takeup tension arm), and scrape-flutter idler.

Step 6: Move the demagnetizer at least three feet from the recorder before de-energizing it.

4B.3 LUBRICATING

4B.3.1 General

The only components requiring lubrication are bearings in the capstan drivemotor, capstan idler, and scrape-flutter idler. Ampex Lubricating Oil (Catalog Nos. 4010825 or 087-579) should be used for the drive motor and capstan idler. (Equivalent oils are Esso Standard Oil Co., Teresso No. 47; and Socony Mobil Oil Co., Mobiloil DTE, Medium.) Scrape-flutter idlers require the special equipment and oil described in paragraph 4B.3.4.

4B.3.2 Drive Motor Initial Lubrication

When the equipment is first received (or a replacement motor is installed) the motor bearing might have dried out, even with oil in the reservoir. Running the motor may result in bearing damage before the oil reaches it, so lubrication before operation is required as follows:

Step 1: Use a knife blade (or similar tool) to gently pry the cone-shaped dust cap (item 11 or 12, Fig. 6-8) from the top plate. This exposes a portion of the motor bearing.

Step 2: Manually rotate the capstan while applying four or five oil drops around the base of the capstan shaft (where it enters the motor).

Step 3: After the oil works down around the shaft, secure the takeup tension arm away from the rest position with a piece of pressure-sensitive tape.

Step 4: Apply power to the equipment, and allow the drive motor to operate for approximately 15 minutes.

Step 5: Wipe off any excess oil and replace the dust cap. Remove the tape.

4B.3.3 Motor/Idler Three-Month Lubrication

Every three months, or after each 1,000 hours of operation, (whichever occurs first) lubricate the drive motor and capstan idler as follows:

For drive motor lubrication, pry off the capstan dust cap. On motors that have an oil hole in the end bell, fill the oil reservoir through that hole. On motors without an oil hole, lubricate by applying 10 drops of oil around the base of the capstan shaft, do not overlubricate (the oil will reach the bearing through the shaft). Wipe off excess oil, and replace the dust cap.

For capstan-idler bearing lubrication pry the dust cap from the idler hub. On the exposed felt washer, place not more than three drops of oil.

CAUTION

If oil gets on the idler rubber tire, immediately remove it with isopropyl alcohol. Oil will deteriorate the tire.

4B.3.4 Idler Yearly Lubrication

Ultrasonic-clean and lubricate the scrape-flutter idlers once a year, or after each 2,000 hours of operation (whichever occurs first). This may be done by a local jeweler or watchmaker, who would usually have the ultrasonic cleaner and special jewel oil required. Disassemble and oil the idler as follows:

4B.3.4.1 Disassembly/Lubrication

Step 1: Remove head per paragraph 4A.2.3

Step 2: The idler is secured to the top plate by one screw and lockwasher. Remove screw and lift idler off locating pin. Retain screw and lockwasher for future use.

Step 3: To indicate correct positioning, scribe-mark the holders at the setscrew centerlines (see Fig. 6-7): upper holder on the top circular surface, and the lower holder on the periphery.

Step 4: Remove the two jewel holders and the roller, by loosening the two setscrews (item 6, Fig. 6-7) at the front and sliding holders (item 1, Fig. 6-7) out of yoke (item 4, Fig. 6-7).

Step 5: Ultrasonically clean the two holders and the roller.

NOTE

If cleaning doesn't remove all traces of oxide from the roller shafts, polish it off with jeweler's rouge (or equal). After polishing, re-clean the roller ultrasonically.

Step 6: Lubricate each jewel bearing with one drop of jewel oil (or Ampex precision instrument oil No. 087-239) applied with a No. 21 gauge hypodermic needle.

4B.3.4.2 Reassembly

Assemble the idlers with great care as follows:

Step 1: Align the scribe marks with the centerline of the setscrews as shown in Fig. 6-7.

Step 2: Tighten the setscrew on the lower jewel holder.

Step 3: Apply slight finger pressure on the upper holder, to eliminate endplay, then tighten the upper setscrew.

Step 4: Check that the idler rotates freely. If it doesn't, readjust setscrews to reduce friction.

4B.4 PERFORMANCE CHECKOUTS4B.4.1 General

These checkouts should be regularly scheduled to determine when tape transport adjustment/alignment is required. Adjustment/alignment procedures are given in part C of this section. Erased tape or blank tape can be used for the performance checks or recorded tape can be erased during the recording portion of the procedure. Reproducer checkout is explained at the start of each checkout procedure.

NOTE

Always bulk-erase any tape that was recorded on equipment with a different head configuration, to make sure that it is completely erased.

4B.4.2 Test Equipment

Obtain the following test equipment, or equivalent:

1. Signal Generator, Hewlett-Packard Model 200C.
2. Vacuum Tube Voltmeter, AC, Hewlett-Packard Model 400D.

3. Wave analyzer (if available).
4. Flutter Meter, Mincom (Bahr) Model B8100.
5. Ampex Standard 1/4-inch Flutter-Test Tapes, as applicable:
 - 15 ips No. 01-31316-01
 - 7-1/2 ips: No. 01-31326-01
 - 3-3/4 ips: No. 01-31336-01
 (flutter tapes for 1/2-inch equipment are available on special order.)

6. Noise Filter (see Fig. 4B-1) or ASA "A" Curve Filter (see Fig. 4B-2)

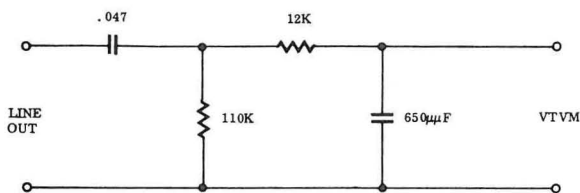

Fig. 4B-1. Noise Filter Schematic

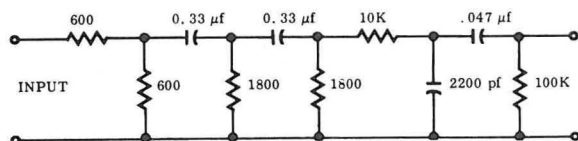

Fig. 4B-2. ASA "A"-Curve Filter Schematic 04773

4B.4.3 Test Conditions

Check that the following test conditions are met:

1. LINE TERMINATION switch (on back of electronics assemblies) at ON, to terminate equipment.
2. Dummy plug in INPUT ACCESS socket (instead of accessory transformer or preamp connector).
3. Heads cleaned and demagnetized.
4. Top and bottom covers installed on electronic assemblies.
5. Low-noise tape, Ampex Series 404 or equal, installed.

4B.4.4 Frequency Response Checkout

4B.4.4.1 AG-445B Checkout

The frequency response of a reproducer can be checked with a tape recorded on a correctly-adjusted recorder with the same head configuration as the reproducer (if unavailable, use a standard tape per paragraph 4C.3.7, steps 2 through 9 keeping in mind the low-frequency limitations given for this tape).

4B.4.4.2 AG-440B Checkout

The following procedure gives a precise indication of overall frequency response, using external meters (an alternate checkout accurate within approximately ±1 dB, using the equipment VU meters is described in paragraph 4B.4.4.3).

Step 1: Apply power, and thread blank tape on the transport. Select the desired tape speed, and set REEL switches for reel hub sizes in use.

Step 2: Connect signal generator to the INPUT receptacle and set it to 500 Hz at a nominal 1-volt rms level.

Step 3: Connect the vtvm to OUTPUT receptacle.

Step 4: Set OUTPUT SELECTOR to INPUT, and adjust RECORD LEVEL for the vtvm indication in Table 4B-1 (the level depends on tape speed, and whether equipment is strapped for +8 dBm or +4 dBm operating level output).

Step 5: Place tape in motion, with test channel in the record mode.

Step 6: Set OUTPUT SELECTOR to REPRO, and adjust REPRODUCE LEVEL for the output level given in Table 4B-1. While simultaneously recording and reproducing, change the signal generator frequency in uniform steps. The response on the vtvm should be within specifications, throughout the frequency range for the tape speed used (refer to Table 1-2, Specifications).

OUTPUT STRAPPING	TAPE SPEED	SET FOR VTVM INDICATION:
+8 dBm	15 ips	0 dBm
	7-1/2 ips	-10 dBm
	3-3/4 ips	-10 dBm
+4 dBm	15 ips	-4 dBm
	7-1/2 ips	-14 dBm
	3-3/4 ips	-14 dBm

Table 4B-1. Record Level Setting

Step 7: For two-channel equipment with an additional quarter-track head, set controls for the quarter-track head and repeat Step 6 on track one. Check track two per paragraph 4B.4.4.3.

Step 8: Set equipment to second tape speed and repeat procedures starting with Step 4.

Step 9: Repeat the procedure for each additional channel.

Step 10: Any of the following corrective actions may be required to bring the equipment within specifications:

- a. Heads, clean/demagnetize per paragraphs 4B.1 and 4B.2.
- b. Signal generator, adjust for a flat output.
- c. Head azimuths, adjust per paragraphs 4C.3.6 and 4C.3.8.
- d. Bias level, adjust per paragraph 4C.3.7.
- e. Reproduce equalization, adjust per paragraphs 4C.3.7 and 4C.3.9.

- f. Record calibration, adjust per paragraph 4C.3.7.
- g. Record equalization, adjust per paragraph 4C.3.10.
- h. Tape tensions, adjust per paragraph 4C.2.3.

4B.4.4.3 Frequency Response Check

A check of frequency response, accurate to approximately ± 1 dB, can be made using an Ampex Standard Alignment Test Tape, a signal generator, and the equipment VU meter(s). The check can be made simultaneously on all channels, because test tapes are full-track recorded and the signal generator can be connected in parallel to all INPUT connectors. Catalog numbers of the test tapes are given in Table 4C-4.

Step 1: Apply power and set tape speed. Set REEL switches for reel hub sizes in use.

Step 2: Thread the applicable standard alignment tape on the transport.

Step 3: Start the tape in motion to find the level-set tone on the tape. (At 3-3/4 and 7-1/2 ips, only the last tone on the tape is at the standard operating level.)

Step 4: During level-set tone reproduction, adjust REPRODUCE LEVEL control(s) for a 0 VU meter indication and lock the control(s).

Step 5: Wind tape back to its original reel (as explained in paragraph 4C.3.1c) and remove the reel.

Step 6: Connect the signal generator to the INPUT connector(s), then set it for a nominal 1-volt rms output at 1,000 Hz (15 ips), or 500 Hz (7-1/2 ips), or 250 Hz (3-3/4 ips).

Step 7: Thread blank tape on transport and start it in motion, with the test channel(s) in the record mode.

Step 8: Set OUTPUT SELECTOR to INPUT and adjust the RECORD LEVEL control(s) for a 0 VU meter(s) indication.

Step 9: For tape speeds of 3-3/4 ips and 7-1/2 only, record and reproduce (switch OUTPUT SELECTOR between INPUT and REPRO) while gradually reducing the RECORD LEVEL control setting, and advancing the REPRODUCE LEVEL control setting. Continue adjustment as far as possible, while maintaining a VU meter indication of 0 at the REPRO setting. It should be possible to reduce the record level to between -15 and -20 on the VU meter.

Step 10: Set OUTPUT SELECTOR at REPRO, while still recording and reproducing. Change the frequency of the signal generator in uniform steps across the frequency band of the tape speed being used (refer to Overall Frequency Response specification, Table 1-2). Check the response indicated on the VU meter.

4B.4.5 Overall Signal-to-Noise Check

This check requires a noise filter or an ASA "A"-curve filter to attenuate noise outside of the audible frequencies. Schematic diagrams of the filters are given in Figures 4B-1 and 4B-2. With the noise filter, signal-to-noise ratio is computed, conventionally, from a peak record level at 6 dB above normal operating level. Therefore, on equipment strapped for a +8 dBm operating level, the vtvm noise indication must be increased in magnitude by 14 dB (i.e. a vtvm reading at -46 becomes -60 dB. On equipment

strapped for a +4 dBm operating-level output, the vtvm indication must be increased in magnitude by 10 dBm. When an "A" weighted-curve noise measurement is being made, using the ASA filter, increase the vtvm indication by 10 dB for a +8 dBm output, or 6 dB for a +4 dBm output. Check signal-to-noise ratio of the recorded reproducer as follows:

Step 1: Apply power, and thread blank tape on transport. Set tape speed and set REEL switches for reel hub sizes in use.

Step 2: Connect the signal generator to the INPUT receptacle, then set it to 500 Hz at a nominal 1-volt rms level.

Step 3: Connect the chosen filter to the OUTPUT receptacle, then connect the vtvm to the filter output.

Step 4: Set OUTPUT SELECTOR at INPUT. Adjust the RECORD LEVEL for a vtvm indication of +14 dBm (if strapped for a +8 dBm output) or +10 dBm (if strapped for a +4 dBm output).

Step 5: Place the tape in motion, with the test channel in the record mode (be sure the head gate is closed). Record a section of tape with the 500 Hz signal (recorded at peak level).

Step 6: Stop the tape and rewind it to the beginning of the recording just made.

Step 7: Disconnect the signal generator from the INPUT receptacle. Set OUTPUT SELECTOR to REPRO.

Step 8: Start the tape in motion (with the test channel in the record mode), but with no input signal (be sure the head gate is closed). The noise level (while thus erasing the 500 Hz signal) will be indicated on the vtvm.

Step 9: Repeat Steps 4 through 8 at second tape speed.

Step 10: Repeat the procedure for each additional channel.

Step 11: To check reproducer noise, remove the tape and connect the vtvm through the

noise filter to the OUTPUT receptacle. With pressure-sensitive tape, or a rubber band, secure the takeup tension arm away from the safety switch. Press the PLAY pushbutton, the signal-to-noise should be as shown in Table 4B-2 (the figures are also computed from peak level, as explained in the overall check).

4B.4.5.1 Noise Causes and Corrections

If the signal-to-noise ratio fails to meet the specifications in Section 1, check for all possible causes, including the following:

- a. Head gate open during noise check.
- b. Magnetic tape not as specified; correct per paragraph 4B.4.3.
- c. External fields from nearby motors, generators, etc; provide shielding or separate the equipment.
- d. Heads need cleaning or demagnetizing; correct per paragraphs 4B.1 and 4B.2.
- e. Erase current not at peak; correct per paragraph 4C.3.7 steps 12 thru 14.
- f. Head cables being rubbed by transport moving parts.
- g. Head azimuth incorrectly adjusted; correct per paragraphs 4C.3.6 and 4C.3.8.
- h. Head height incorrectly adjusted; correct per paragraph 4D.2.
- i. Tape wrap or head zenith incorrectly adjusted; correct per paragraph 4D.3.
- j. Record or reproduce level incorrectly adjusted; correct per paragraph 4C.3.7.

4B.4.6 Overall Distortion Check

For accurately checking distortion, use a wave analyzer which measures individual distortion products (instruments that measure total harmonic distortion are affected by tape noise and modulation noise). Also, to avoid error, use a signal generator with less than 0.1% distortion.

To check distortion, record a 500-Hz signal on blank tape, at normal operating level, then reproduce the signal. The second harmonic content should not exceed 0.2%, and the third should be 0.6 to 1.1%.

Check reproducer distortion with a tape recorded on a unit that is correctly adjusted, and has a head track configuration identical to the reproducer.

4B.4.6.1 Distortion Causes

Excessive second harmonic distortion is usually caused by magnetized heads, or a malfunctioning bias oscillator, bias amplifier, record amplifier, or reproduce amplifier. To eliminate a high second-harmonic distortion, check the erase-adjust control per paragraph 4C.3.7, adjust the slugs in T3 and T4 of the bias amplifier card (on an extender) using plastic tuning wand of the proper size, but don't adjust them so the second-harmonic distortion at the output is less than the distortion of the signal generator in use.

Third harmonic distortion may result from the type of magnetic tape used, the bias setting, or the accuracy of the "normal operating level" adjustment. Most tape will have a third harmonic distortion of 0.8% to 1.1% at operating level.

4B.4.7 Flutter Check

This check must be made with Ampex Standard Flutter Test Tapes (refer to paragraph 4B.4.2). These tapes, recorded on very precise equipment, have an inherent flutter below 0.3% rms--which can be ignored. Flutter test tapes must be used only at the speed they are made for. For storage and handling of standard

TAPE SPEED	HEAD TYPE (1/4-inch tape)	REPRODUCE CIRCUIT SIGNAL/NOISE
3-3/4 ips	Full Track	66 dB
	Half Track	61 dB
	Two Track	61 dB
7-1/2 ips	Full Track	70 dB
	Half Track	66 dB
	Two Track	66 dB
15 ips	Full Track	70 dB
	Half Track	66 dB
	Two Track	66 dB
TAPE SPEED	HEAD TYPE (1/2-inch tape)	REPRODUCE CIRCUIT SIGNAL/NOISE
7-1/2 ips	Three Track	66 dB
	Four Track	66 dB
15 ips	Three Track	66 dB
	Four Track	66 dB

Table 4B-2. Reproduce Signal/Noise from Peak Record Level

tapes refer to paragraph 4C.3.1. Flutter measurement is the same for the reproducer and the record/reproduce units.

Flutter meters are sensitive to amplitude modulation that results from poor head-to-tape contact or from signal dropouts. Therefore heads must be cleaned and demagnetized per paragraphs 4B.1 and 4B.2 before flutter tests are made.

This procedure applies to the use of the Mincon (Bahr) Model B8100 flutter meter. If a different flutter meter is used, the manufacturer's instructions should be followed. Check tape flutter as follows, on any correctly aligned reproduce channel:

Step 1: Set RECORD SELECTOR on all record/reproduce units to SAFE (to avoid accidentally entering the record mode, which will erase the flutter-test tape).

Step 2: Connect reproduce channel OUTPUT connector to the flutter meter EXT SIGNAL, SIGNAL INPUT connector.

Step 3: On the flutter meter, set FLUTTER WEIGHTING to NAB UNWTD; MOD INPUT SELECT to 100 MB-5V EXT SIGNAL; and FLUTTER % FULL SCALE to 0.1% or 0.3% (depending upon tape speed).

Step 4: Apply power to the recorder and the flutter meter.

Step 5: Thread the flutter-test tape on the tape transport, with the tape reel on the takeup turntable. Rewind the tape to a reel on the supply turntable. Set tape speed to conform to the test tape. Set REEL switches for the reel hub sizes in use.

Step 6: Start the test tape in motion in the reproduce mode (NORMAL lamp on flutter meter should light, otherwise there is no reproduce output to the meter, the DEMOD INPUT SELECT is incorrectly positioned, or lamp circuit is defective).

Step 7: Read indication on the FLUTTER meter, and if necessary, reposition the FLUTTER % FULL SCALE control. Flutter

COMPONENT	TAPE SPEED		
	3-3/4 ips	7-1/2 ips	15 ips
	ROTATIONAL RATE (Hz)		
Drive Motor (Capstan)	10	20	20
Capstan Idler	0.6	1.2	2.4
Reel Idler	0.8	1.6	3.2
Scrape-Flutter Idler (Normal)	3.4	6.3	12.7
(Optional)	2.5	5.1	10.2

Table 4B-3. Rotational Rates

should meet the specification given in Table 1-2.

Step 8: Allow the flutter-test tape to completely unwind from the supply reel.

4B.4.7.1 Flutter Causes

Excessive flutter can be caused by any component that affects the tape motion, but is usually caused by the following:

- a. Oxide or dirt; on components in the tape-handling path.
- b. Drive motor; not in synchronism (too-low line voltage); excessive tape tension; defective motor capacitor; bearings defective or need lubrication; or motor shaft bent.
- c. Supply motor; excessive or erratic holdback tension; dragging brakes; or bent shaft.
- d. Capstan idler; defective rubber tire; bearing defective or needs lubrication; pressure incorrectly adjusted.
- e. Reel idler; bent shaft; flywheel not balanced; damaged bearing.
- f. Head assembly; poor tape guiding.

- g. Tape scrape; warped or damaged reels.

4B.4.7.2 Flutter Troubleshooting Aids

As an aid in troubleshooting, a sound-and-vibration analyzer (such as General Radio Type 1564-A) can be used to isolate flutter to certain frequencies, by connecting the analyzer to the flutter meter output. Compare the results with the rotational rates in Table 4B-3 for an indication of the cause of trouble.

If flutter is caused by the supply motor assembly, the frequency will vary from low, when the tape quantity on the supply reel is large, and will progressively increase as the tape quantity gets smaller. The takeup motor assembly seldom causes appreciable flutter, because it is isolated from the heads by the capstan and capstan idler. If it causes flutter, the frequency would vary inversely to that of the supply motor (high with a small tape pack on the takeup reel and decreasing as the pack increases).

Section 4

MAINTENANCE

Part C. Adjustment and Alignment

4C.1 GENERAL

When a failure is noted during the performance checks of Routine Maintenance (part B) the following applicable adjustment or alignment procedures must be performed:

Transport Adjustment Procedures paragraph 4C.2; Electronic Alignment Procedures, paragraph 4C.3; and Sel Sync Adjustments, paragraph 4C.4; Procedures for removal/installation, special positioning, and troubleshooting are included in Corrective Maintenance as follows: Part D, Heads; Part E, Tape Transport; and Part F, Electronic Assemblies.

4C.2 TAPE TRANSPORT ADJUSTMENTS

4C.2.1 Test Equipment

Obtain the following equipment or equivalent:

1. Spring scales, 0-16 oz. and 0-10 lbs, Chatillon.
2. Cord or twine, about 30 inches long, with small loop at one end.
3. Empty reel, NAB hub.

4. Technician tools.

4C.2.2 Different Tape Sizes

Tape transports for one or two-channel equipment are adjusted at the factory for use with 1/4-inch tape. Transports for three or four-channel equipment are adjusted for use with either 1/4-inch or 1/2-inch tape (so the quick conversion feature can be used). If only one tape width is to be used, make adjustments for that tape only. In the following procedures, correct indications are given for all three conditions of operation:

- a. For a transport used only with 1/4-inch tape.
- b. For a transport used only with 1/2-inch tape.
- c. For a transport used with both 1/4-inch and 1/2-inch tape.

4C.2.3 TAPE TENSION (See Figure 4C-1)

Tape tension is determined indirectly by measuring the torque of both tape reel motors. Required tension adjustments are made by positioning sliders on the resistors under the cover of the transport control box. The resistors, and what they adjust, are listed in Table 4C-1. The circuit schematic is shown on Figure 6-20.

CAUTION

WHEN TRANSPORT POWER SWITCH IS ON, FULL LINE VOLTAGE IS PRESENT AT THE RESISTORS. TURN POWER OFF WHEN ADJUSTING THESE RESISTORS.

In the following steps, an empty NAB 4-1/2 inch hub) reel is used, and the cord (or twine) is wrapped, on the reel being checked, in the same direction as recording tape is pulled onto that reel. The spring scale is hooked onto a small loop formed in the free end of the cord and is held stationary, with little or no slack in the cord, so that it will indicate cord tension when PLAY or a FAST WIND button is pushed. Always assure that both the REEL HUB size switches are in the same position during the test procedures.

NOTE

An empty EIA (2-1/4" hub) reel may be used, but in this event, all of the scale readings of tables 4C-1 and 4C-2 must be doubled in value.

a. In adjusting resistors during the following steps, loosen contact screws just enough to slide the contacts, then tighten screws just enough to make good electrical contact.

b. Turn power ON and set SPEED to high or low.

c. Use tape or a rubber band, to hold the take-up tension arm away from the safety switch.

d. Install the empty NAB reel on the take-up turntable and set the REEL HUB size

switches to the SMALL REEL HUB position. Press the FAST FORWARD button and adjust R606 for 8 to 9 oz.

e. Press STOP. Press the PLAY button and adjust R605 for the scale reading given in Table 4C-1 in the PLAY TENSION column for the tape width used. Switch the REEL HUB switches to the LARGE REEL HUB position and check for the scale reading given in Table 4C-1 in the PLAY TENSION column for the tape width used. It may be necessary to switch between LARGE REEL HUB position and SMALL REEL HUB position to optimize R605 in both positions. If these specs cannot be met, return to step d. and readjust R606 slightly, but within range of its specified tension, then repeat step e.

f. Press STOP. Place the REEL HUB size switches in the LARGE REEL HUB position. Press the REWIND button and adjust R607 for 1/2 to 1 oz.

g. Press STOP. Install the empty NAB reel on the supply turntable and set the supply REEL HUB size switches to the SMALL REEL HUB position. Press the REWIND button and adjust R608 for 8 to 9 oz.

h. Press STOP. Press the PLAY button and adjust R604 for the scale reading given in Table 4C-1 in the PLAY TENSION column for the tape width used. Switch the REEL HUB switches to the LARGE REEL HUB position and check for the scale reading given in Table 4C-1 in the PLAY TENSION column for the tape width used. It may be necessary to switch between LARGE REEL HUB position and SMALL REEL HUB position to optimize R604 in both positions. If these specs cannot be met, return to step g, and readjust R608 lightly, but within range of its specified tension, then repeat step h.

Tape Usually in Use	PLAY Tensions Hold-back Tension. Adjust R604 Take-up Tension. Adjust R605		FAST MODE Tensions	
			Small Reel Hub Fast Forward Take-up Tension. Adjust R606	Hold-back Tension. Adjust R607
			Small Reel Hub Rewind Take-up Tension. Adjust R608	Small Reel Hub Position Hold-back Ounces
	SMALL REEL HUB Position Ounces	LARGE REEL HUB Position Ounces	Small Reel Hub Position Take-up Ounces	Small Reel Hub Position Hold-back Ounces
1/4 inch	2-1/2 to 3-1/2	5 to 6	8 to 9	1/2 to 1
1/2 inch	N/A	8 to 11	8 to 9	1/2 to 1
Both	3 to 4	6 to 7	8 to 9	1/2 to 1

Table 4C-1. Tape Tension Adjustments (NAB 4-1/2" Hub Reel)

TAPE USED	SUPPLY REEL	TAKEUP REEL
	CCW Motion	CW Motion
1/4-inch (only)	15 to 17 oz.	15 to 17 oz.
1/2-inch (only)	16 to 21 oz.	16 to 21 oz.
1/4-inch and 1/2-inch	15 to 17 oz.	15 to 17 oz.

Table 4C-2. Main Brake Force*

4C.2.4 Brakes *(See Table 4C-2)

The main brake system on each reel stops reel rotation and maintains tape tension. An edit brake system partially releases the brake bands to reduce braking force when the stop/edit mode is selected.

Torrington clutches on both brake drums eliminate CW braking of the supply reel and CCW braking of the takeup reel. Braking is applied only to the reel supplying the tape at the time STOP mode is initiated.

Required adjustments are made with the nuts shown in Fig. 4C-2; in adjusting the main braking force, the two nuts for the main brake adjustment must be turned equally.

Step 1: Apply power to equipment. Place the NAB reel on the supply turntable.

Step 2: Wrap the cord or twin on reel hub counterclockwise with the loop at the cord free end.

Step 3: Insert the spring scale hook in cord loop. Pull the scale to rotate the reel and check the scale indication while the reel is moving slowly and steadily. Adjust brake nuts as necessary (screw in to increase force, and out to decrease force).

NOTE

The force required to start reel rotation will be much higher than that required when the reel is rotating slowly and steadily.

*Brake force is affected by humidity and temperature extremes.

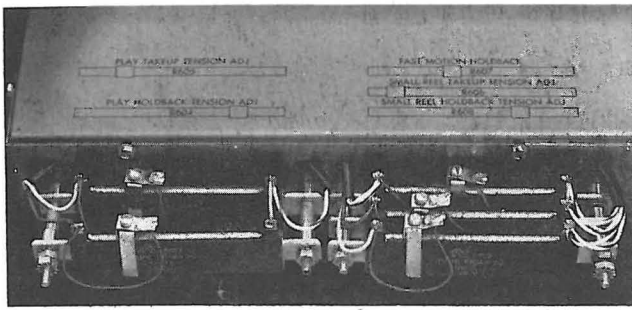

Fig. 4C-1. Tape Tension Adjustments

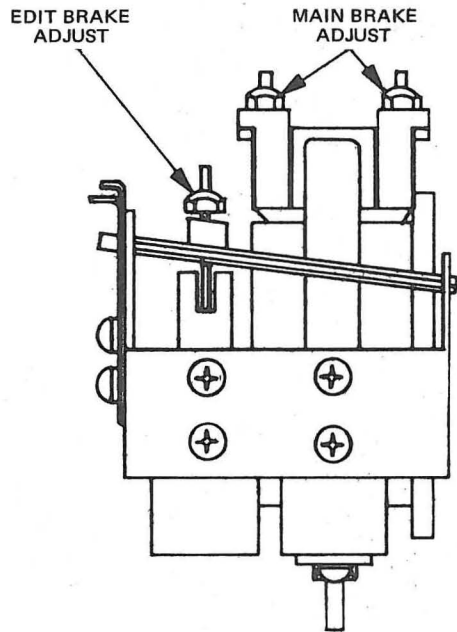

Fig. 4C-2. Brake Adjustments

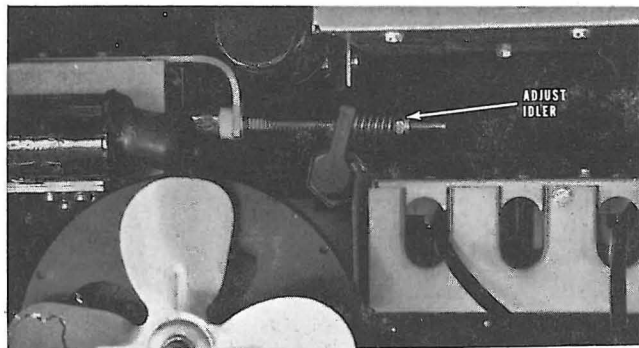

Fig. 4C-3. Capstan Idler Adjustment

IDLER AT INSTANT IT LEAVES CAPSTAN

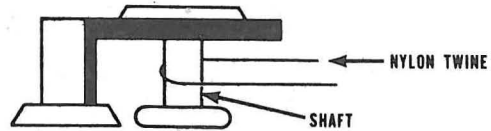
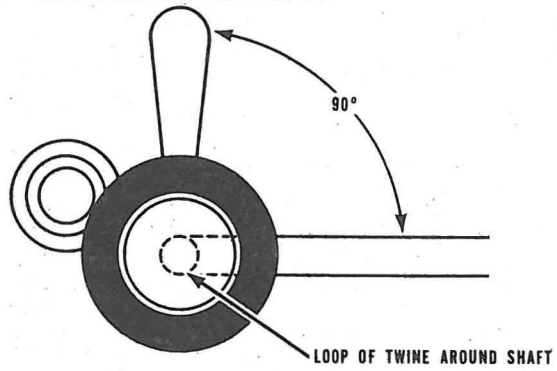

Fig. 4C-4. Capstan Idler Force Measurement

PLUG-IN BOARD VOLTAGE ADJUST

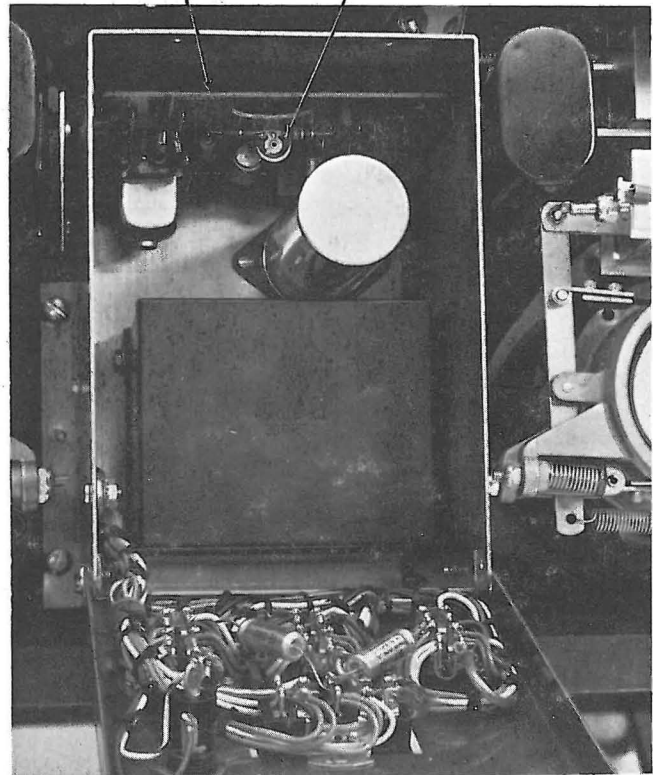

Fig. 4C-5. Power Supply Box Interior

Step 4: Rewind the cord on the reel hub, counterclockwise. Press the EDIT pushbutton.

NOTE

In the following steps, edit brake force can be set as preferred by each operator. The minimum tension specified ensures holding the takeup tension arm away from the safety switch.

Step 5: Insert the spring scale hook in the cord loop. Pull the scale to rotate the reel and check the scale indication while the reel is moving slowly and steadily. Scale should indicate 1 to 4 ounces. Adjust edit-brake nut as necessary (screw in to decrease force, and out to increase force). Adjust so there is no braking difference between the directions of rotation. Press the STOP pushbutton.

Step 6: Move the empty reel to the takeup turntable. Wind the cord on the hub clockwise. Measure and adjust brake nut per Step 3.

Step 7: Rewind the cord on the reel hub clockwise. Press EDIT pushbutton. Measure and adjust the edit braking force per Step 5.

Step 8: Press the STOP pushbutton.

4C.2.5 Capstan Idler (See Figures 4C-3 and 4C-4)

The capstan idler force against the moving capstan is determined by the capstan solenoid spring. The force is adjusted by a lock nut on the capstan solenoid spade bolt shown in Figure 4C-3.

As the solenoid temperature rises, its resistance also rises. When power line regulation is poor, allow 30 minutes or more for warm-up (operating in the reproduce mode) before adjusting the capstan idler force. At the factory, the solenoid is checked to be sure it will bottom at line voltages of 90 volts (cold) and 105 volts (hot).

Step 1: Apply power to equipment. Use pressure-sensitive tape or a rubber band to hold takeup tension arm away from the safety switch.

Step 2: Tie the cord together to form a continuous loop. Place the loop around the capstan idler shaft as shown in Fig. 4C-4.

Step 3: Press PLAY pushbutton (the idler moves to contact the capstan, and then both rotate).

Step 4: Insert the spring scale hook through the loop, then pull the cord taut at a 90° angle to the idler arm.

Step 5: Pull on the scale, and note the scale indication when the idler just loses contact with the capstan (the idler stops when touched).

Step 6: If indications are not as shown in Table 4C-3, adjust idler spring-tension nut as necessary. After any adjustment, check that capstan-idler solenoid bottoms in the reproduce mode; if it doesn't, screw out spring-tension nut until it does.

4C.2.6 Tape Lifter

The automatic tape lifter is actuated by a solenoid that energizes in either of the fast-wind modes. A spring mechanically couples the solenoid plunger to the tape lifter. When deenergized, no slack is permitted between the solenoid plunger,

TAPE IN USE	SCALE INDICATION
1/4-inch (only)	6 to 7 lbs
1/2-inch (only)	6 to 7 lbs
1/4 and 1/2-inch	6 to 7 lbs

Table 4C-3. Capstan Idler Force

the spring, and the tape lifter bracket. However, the spring should not be extended, and the tape lifter arms should be 1/16-inch from the slot end. When the solenoid energizes, the tape lifter arms should stop 1/16-inch from the other end of the slot.

If any of these conditions are not met, a complete adjustment of the tape lifter is required per paragraph 4E.9.

4C.3 ELECTRONIC ALIGNMENT

4C.3.1 Standard Test Tapes

The system's reproduce function is aligned while playing an Ampex Standard Alignment Test Tape, and the record circuit is then adjusted with the reproduce circuit as a reference.

Standard test tapes are precisely recorded in an Ampex laboratory and must be correctly handled and stored to retain their accuracy. The following requirements should especially be followed:

- a. Clean and demagnetize equipment heads and other tape-handling components before installing the test tape.
- b. Never store test tapes in areas where there are temperature or humidity extremes.
- c. Remove test tapes from equipment only after a normal play run (never after a fast-winding mode).

4C.3.1.1 Tape Degradation

After extensive use, high-frequency

tones may drop as much as 2 dB, and flutter indications may rise even though actual flutter remains unchanged. Flutter increase is caused by: demagnetization of the recorded signal from repeated runs; tape deformation due to tape tension, changes in temperature and humidity; and increased dropouts resulting from tape wear.

The test tape is threaded in the normal tape path (from the supply to takeup turntable). During the alignment procedures, the rewind and fast forward modes may be used as necessary. After alignment, wind the tape completely on the takeup reel, interchange reels, thread the tape, and place the equipment in the reproduce mode to wind the tape back on its original reel.

All tones on 15-ips standard alignment tapes are recorded at operating level. On slower speed tapes, all tones are recorded 10 dB below operating level, except for the last tone.

4C.3.2 Test Equipment

Obtain the following test equipment, or equivalent:

1. Voltmeter, dc, 20,000 ohms-per-volt.
2. Vacuum Tube Voltmeter, ac, Hewlett-Packard Model 400D.
3. Signal Generator, Hewlett-Packard Model 200C.
4. Noise Filter, (see Fig. 4B-1) or ASA "A" Curve Filter (see Fig. 4B-2).
5. Ampex Standard Alignment Tapes that apply (see Table 4C-4).

TAPE SPEED	TYPE OF EQUALIZATION	MAGNETIC TAPE	
		1/4-inch	1/2-inch
15 ips	NAB	01-31311-01	01-31311-05
	CCIR	01-31313-01	01-31313-05
7-1/2 ips	NAB	01-31321-01	01-31321-05
	CCIR	01-31323-01	01-31323-05
3-3/4 ips	120 micro sec	01-31331-01	-----
	200 micro sec	01-31334-01	-----

Table 4C-4. Standard Alignment Tapes

6. Technician tools.

4C.3.3 Test Conditions

Check for the following test conditions:

- a. LINE TERMINATION switch at ON.
- b. Dummy plug, instead of accessory transformer or preamp, in INPUT ACCESS socket.
- c. Heads cleaned and demagnetized.
- d. Covers installed on electronic units.
- e. Magnetic tape of low-noise type, Series 404, or equivalent.

4C.3.4 Alignment Procedures Introduction

Procedures in paragraphs 4C.3.5 through 4C.3.8 will usually correct deficient operation. Other adjustments (seldom required) are 4C.3.9 and 4C.3.10. Sel-Sync adjustments are described in paragraph 4C.4.

4C.3.5 Power Supply (See Figure 4C-5)

The power supply (with the bias and erase oscillator) is mounted on a plug-in printed circuit board in the transport power supply box. Operation can be checked by connecting the dc voltmeter across pin 9 (positive) and pin 5 of any of the four receptacles (J701 through J704) on the power supply box. With the equipment operating in the reproduce mode, the voltmeter should

indicate 39 (-1/2, +1) volts.

If adjustment is necessary, open the cover on the power supply box (see Fig. 4C-5).

WARNING

Full line voltage is present in the box. Do not touch the fuse post or transformer leads while the system is energized.

With the voltmeter connected as previously described, place the equipment in the reproduce mode, then adjust R712 (see Fig. 4C-5) for an indication of 39 (-1/2, +1) volts.

4C.3.6 Reproduce-Head Azimuth (See Fig. 4C-6)

The VU meter on each record/reproduce unit can be simultaneously used to measure the output of each head. This simultaneous metering facilitates determination of the optimum setting. For a reproducer, use a vtm for each head track, or use one vtm to adjust one head and then another-working back and forth to reach an optimum setting.

Standard alignment tapes for the 15 ips speed have all tones recorded at normal operating level, while standard tapes for slower speeds have all tones (except the last) recorded at 10 dB below operating level. If the recorder/reproducer has a 15 ips speed, make the normal-operating-level adjustment at that speed. If speed is 3-3/4 or 7-1/2 ips, it will probably be necessary to turn the REPRODUCE LEVEL control full

clockwise (do not exceed a VU meter indication of 0) in Step 7. For a reproducer, adjust the level control for any convenient vtm indication.

CAUTION

Do not adjust any nut or screw on the head assembly except the azimuth adjustment nut.

Step 1: Remove the head cover by loosening the captive screw on its angled back surface.

Step 2: Apply power to equipment. Set tape speed (15 ips if available) and set REEL switches for reel sizes in use.

Step 3: Set RECORD SELECTOR switches on all record/reproduce units to SAFE (this prevents accidentally entering the record mode and erasing the test tape).

Step 4: Set OUTPUT SELECTOR switch(es) on all record/reproduce units to REPRODUCE.

Step 5: Thread the correct speed test tape on the transport. If this is a reproducer, connect the vtm(s) to the output connector(s).

NOTE

Voice announcements on the test tape can be monitored through headsets, or by an amplifier/speaker connected to the phones jack, or to the output.

Step 6: Start the test tape in motion in the reproduce mode.

Step 7: For adjustments at 15 ips tape speed, adjust the REPRODUCE LEVEL control on each record/reproduce unit for an indication of 0, as the first tape tone is reproduced. (Any convenient indication on the vtm is used for a reproducer. If a slower speed is being used, and it is impossible to achieve this level, set the REPRODUCE LEVEL control to the full-clockwise position.

Step 8: The second tone on the test tape is the azimuth adjustment tone. As this tone reproduces, adjust the reproduce head azimuth adjustment nut (not the screw) for a maximum output indication on the VU meters (or vtm). On multi-channel equipment, if all heads do not peak at the same setting, adjust for optimum output of all the heads.

NOTE

If the azimuth is far out of adjustment, minor peaks will appear on each side of the correct setting. Correct adjustment results in an output markedly higher than the minor peaks.

Step 9: Replace the head cover.

4C.3.7 Reproduce/Record Alignment

The initial alignment run, for setting bias and record levels, should be made at the speed at which the equipment will usually be run. When both speed pairs will be used about equally, the initial run should be made at 7-1/2 ips (which provides optimum bias and record adjustments for both speed pairs). The second run, at the other speed, will then be made only for reproduce equalization at that speed.

For a reproducer, perform Steps 1 through 9 for reproduce equalization, using a vtm.

Step 1: Remove cover from record/reproduce unit front panel (or reproducer electronics tray).

Step 2: Apply power to equipment. Set tape speed, and set REEL switches for reel hub sizes.

Step 3: Set RECORD SELECTOR switches on all record/reproduce units to SAFE (this prevents accidentally entering the record mode and thus erasing the standard tape).

Step 4: Set OUTPUT SELECTOR switch of record/reproduce channel under test to REPRODUCE.

OUTPUT STRAPPING	TAPE SPEED	SET AT VTVM INDICATION:
+8 dBm	15 ips	+8 dBm
	7-1/2 ips	-2 dBm
	3-3/4 ips	-2 dBm
+4 dBm	15 ips	+4 dBm
	7-1/2 ips	-6 dBm
	3-3/4 ips	-6 dBm

Table 4C-5. Reproduce Equalization Output

Step 5: Connect vtvm to OUTPUT connector of the channel under test.

Step 6: Thread correct-speed test tape on transport.

Step 7: Start test tape in motion in the reproduce mode. As the first tone reproduces, adjust REPRODUCE LEVEL control for the output level indication shown on Table 4C-5. Lock the control in that position.

Step 8: Reproduce the test tone series from the recorded test tape, starting with the highest frequencies. Adjust the appropriate HIGH FREQ control (at the front of reproduce board) as necessary for the flattest possible response, within specifications, but do not move response more than ± 2 dB from the theoretical response curve (refer to Figs. 6-32, 6-33, and to paragraph 4F.10). If further adjustment is indicated, there is trouble in the record/reproduce process not correctable by equalization adjustment.

NOTE

The test tape is recorded full track. When reproduced by a half-track or multi-track head, the "fringing" effect produces invalid response at frequencies below 700 Hz (15 and 7-1/2 ips) or 500 Hz (3-3/4 ips). This effect, which results in high indications in the lower frequencies, does not occur when tapes are recorded and reproduced

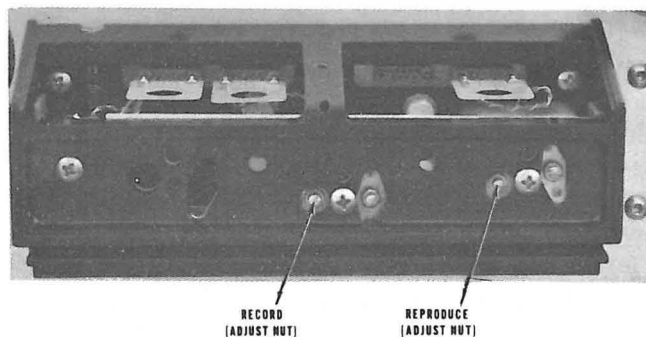

Fig. 4C-6. Head Azimuth Adjustments

with heads mounted in the same configuration.

Step 9: For tests at 7-1/2 or 3-3/4 ips tape speed, as the last tone reproduced, adjust the REPRODUCE LEVEL control for a vtvm indication of +8 dBm, or +4 dBm (depending on equipment strapping). The VU meter should indicate 0 ($\pm 3/4$ dB).

NOTE

This completes the reproduce equalization adjustment and reproduce level setting, as required for record calibration. Do not change this reference level until after Step 18.

Step 10: Wind the test tape on its original reel, in the reproduce mode (per paragraph 4C.3.1), and remove the reel.

Step 11: Connect the signal generator to the INPUT connector, with the vtvm still connected to the output.

Step 12: Set the signal generator to provide a nominal 1-volt rms output at the frequency that applies: at 15 ips, 1,000 Hz; at 7-1/2 ips, 500 Hz; or at 3-3/4 ips, 250 Hz.

Step 13: Thread blank tape on transport. Set OUTPUT SELECTOR switch to BIAS, and RECORD SELECTOR switch to READY. Start the tape in motion, with the test channel operating in the record mode.

Step 14: Adjust the ERASE ADJ control, (at bias amplifier module front) for a VU meter peak indication, then readjust the BIAS CAL control as necessary to keep the VU meter indicator on scale. The peak is very broad. When the approximate peak is found, turn the control counterclockwise until a distinct drop is indicated on the VU meter. Then turn the control very slowly clockwise to pass through the peak until the meter indication just starts to fall. Return the control setting just to the point where the drop-off started, turning it clockwise.

Step 15: Set OUTPUT SELECTOR switch to REPRO. Adjust BIAS ADJ control for maximum output indication on vtm, turning it clockwise.

Step 16: Reset OUTPUT SELECTOR to BIAS. Adjust BIAS CAL control for a 0 VU meter indication.

Step 17: Reset OUTPUT SELECTOR switch to REPRO. Set the signal generator for a 500 Hz output. Adjust RECORD LEVEL control for a vtm indication of +8 or +4 dBm, depending on equipment output strapping.

Step 18: Set OUTPUT SELECTOR switch to INPUT. Adjust REC CAL control (at record module front) for a 0 VU meter indication.

Step 19: Disconnect the signal generator from INPUT connector.

Step 20: Repeat Steps 2 through 9 for the second tape speed, using the correct speed test tape and adjusting the applicable HIGH FREQ control as necessary.

Step 21: Repeat the complete procedure for each channel (steps 1 through 20).

4C.3.8 Record-Head Azimuth (See Figure 4C-6)

This adjustment (similar to the reproduce head azimuth adjustment) is made while simultaneously recording and reproducing. The record head azimuth is adjusted to coincide with the reproduce head (previously adjusted to a reference position). This procedure doesn't apply to a reproducer.

CAUTION

Do not adjust any head assembly nut or screw, except the nut for azimuth adjustment on the record head.

Step 1: Remove the head cover, by loosening the captive screw on the angled back surface.

Step 2: Connect the signal generator to the INPUT connector. On multi-channel equipment, connect the signal generator to all INPUT connectors (in parallel).

Step 3: Apply power to equipment, set tape speed, and set REEL switches for the reel hub sizes.

Step 4: Set the signal generator for a nominal 1-volt rms output, at the frequency that applies: at 15 ips, 15,000 Hz; at 7-1/2 ips, 15,000 Hz; and at 3-3/4 ips, 7,500 Hz.

Step 5: Thread blank tape on equipment.

Step 6: Set RECORD SELECTOR switch for each channel to READY.

Step 7: Set OUTPUT SELECTOR switch for each channel to INPUT. Then adjust RECORD LEVEL control(s) for the following VU meter indication: at 15 ips, 0; at 7-1/2 ips, -10; and at 3-3/4 ips, -10.

Step 8: Set OUTPUT SELECTOR switch for each channel to REPRO, then start tape in motion with all channels operating in the record mode.

Step 9: While thus simultaneously recording and reproducing, adjust REPRODUCE LEVEL control(s) for 0 VU meter(s) indication. If adjustment is being made at 7-1/2 or 3-3/4 ips, and it is impossible to reach the 0 level, set the REPRODUCE GAIN control at full-clockwise position.

Step 10: Adjust record head azimuth nut (not the screw) for maximum output indications on the VU meter(s). On a multi-channel recorder, if all heads do not peak at the same setting, adjust for optimum output of all heads.

NOTE

Minor peaks may appear on each side of the correct setting. Correct adjustment, however, is indicated by a definitely higher output.

Step 11: Return the reproduce level to normal operating condition, replace the head cover, and change the frequency of the signal generator to 500 Hz.

Step 12: While simultaneously recording and reproducing, set OUTPUT SELECTOR switch to INPUT and adjust the RECORD LEVEL control for a 0 VU meter indication. Then set OUTPUT SELECTOR switch to REPRO and adjust the REPRODUCE LEVEL control for a 0 VU meter indication.

4C.3.9 Low-Frequency Reproduce Equalization

This procedure will seldom be required. The cover must be removed from the front panel of the reproduce/recorder unit (front cover on the reproduce electronic tray).

The reproduce circuit is adjusted to compensate for head "bumps" which occur at low frequencies. The adjustment of a reproducer requires that the head track configuration be the same as on the recorder that made the tape.

Step 1: Connect the vtvm to the OUTPUT connector.

Step 2: Connect the signal generator to the INPUT connector and set it to 500 Hz at a nominal 1-volt rms level.

Step 3: Apply power to equipment. Set tape speed, and set REEL switches for the reel hub sizes.

Step 4: Thread blank tape on equipment.

Step 5: Set OUTPUT SELECTOR switch to INPUT, and adjust the RECORD LEVEL control as necessary for a normal record level (+8 dBm or +4 dBm, depending on equipment output strapping) as indicated on the vtvm.

Step 6: Set OUTPUT SELECTOR switch to REPRO, and start the tape in motion with the test channel operating in the record mode.

Step 7: Adjust REPRODUCE LEVEL control as necessary for a normal operating level (+8 dBm or +4 dBm, depending on equipment output strapping) as indicated on the vtvm.

Step 8: While thus simultaneously recording and reproducing, vary signal generator frequency from 250 Hz to 30KHz, and note the magnitude of any positive-going or negative-going head "bumps".

Step 9: Adjust the applicable LO FREQ control (at front of reproduce board) for the flattest possible response, within specifications. This is done by adjusting head "bump" excursions for an equal magnitude above or below the reference frequency of 500 Hz.

Step 10: Repeat Steps 8 and 9 for the second tape speed.

Step 11: Repeat the complete procedure for each channel.

4C.3.10 Record Equalization

Remove the small cover over the record/reproduce plug-in modules and proceed as follows:

Step 1: Perform Steps 1 through 4 of paragraph 4C.3.9.

Step 2: Set OUTPUT SELECTOR switch to INPUT, and adjust the RECORD LEVEL control for the vtvm indication shown in Table 4C-6 (this establishes the 500 Hz reference level).

TAPE SPEED	OUTPUT STRAPPING	SET FOR VTVM INDICATION
15 ips	+8 dBm +4 dBm	+8 dBm +4 dBm
7-1/2 ips	+8 dBm +4 dBm	-10 dBm -14 dBm
3-3/4 ips	+8 dBm +4 dBm	-10 dBm -14 dBm

Table 4C-6. Record Equalization Level.

Step 3: Change the frequency of the signal generator to conform to the tape speed: at 15 ips, 18,000 Hz; at 7-1/2 ips, 15,000 Hz; or at 3-3/4 ips, 8,000 Hz.

Step 4: Start the tape in motion, with the test channel operating in the record mode.

Step 5: Set OUTPUT SELECTOR switch to REPRO.

Step 6: While thus simultaneously recording and reproducing, change the signal generator frequency in uniform steps over the upper half of the response spectrum for the applicable tape speed. Adjust HI SPEED or LOW SPEED control (at front of record board) for the flattest possible high-frequency response, referenced to 500 Hz, conforming to specifications.

Step 7: Repeat Steps 3 through 6 for the second tape speed.

Step 8: Repeat the complete procedure for each additional channel.

4C.4 SEL-SYNC ADJUSTMENTS

Both adjustments require access to the record/reproduce unit back panels. Sel-Sync adjustments are not applicable to the reproducer.

4C.4.1 Test Equipment

Obtain the following equipment:

1. Ampex Standard Alignment Tape (see Table 4C-4).

2. Technician's tools.

4C.4.2 Test Conditions

Check for the following test conditions:

1. LINE TERMINATION switch (on back of record/reproduce unit) ON.
2. Dummy plug (not the accessory transformer or preamp) in INPUT ACCESS socket.
3. Heads cleaned and demagnetized.
4. Covers installed on electronic units.

4C.4.3 Sel-Sync Level Adjustment

Step 1: Set RECORD SELECTOR switch on each record/reproduce unit to SAFE (this prevents entering the record mode accidentally and thus erasing the tape).

Step 2: Apply equipment power, set tape speed, and set REEL switches for the reel hub sizes.

Step 3: Thread the correct-speed standard alignment tape on the transport.

Step 4: Set OUTPUT SELECTOR switches to REPRO.

Step 5: Run the standard alignment tape to operating-level tone (first tone on 15-ips tape, and last tone on a tape for slower speeds).

Step 6: As the operating-level tone reproduces, adjust REPRODUCE LEVEL controls for 0 VU meter indications.

Step 7: Rewind tape to beginning of the operating-level tone. Set all RECORD SELECTOR switches to SEL SYNC.

Step 8: Place tape in motion in the reproduce mode. As the operating level tone reproduces, adjust SEL SYNC GAIN controls (on back panel of each record/reproduce unit) for 0 VU meter indications.

Step 9: Wind tape on original reel (per paragraph 4C.3.1) and remove reel.

4C.4.4 Sel-Sync Bias Trap Adjustment

When operating with Sel-Sync, the bias from one recording channel could leak into another. Nothing would be recorded on the latter channel, but VU meter monitoring could be masked, so a trap is provided to minimize the leakage.

The bias trap (adjusted at the factory) usually requires no readjustment. If the bias from recording channels affects VU meter indications for other channels, adjust as follows: Operate one channel with Sel Sync, and all other channels in the record mode. Adjust the operating Sel-Sync BIAS TRAP control (on record/reproduce unit back panel) to null the VU meter indication. Repeat the procedure for each channel.

MAINTENANCE

Part D. Head Maintenance

4D.1 GENERAL

Head cleaning and demagnetizing is given in part B, Preventive Maintenance. Head azimuth adjustment is given under Electronic Alignment Procedures in Part C, Adjustment/Alignment. Changing the complete head assembly is described in Part A, Conversion. Head and tape adjustments are given in the following paragraphs. The head height is precisely set at the factory, so head adjustment is seldom required except when a head stack is changed.

4D.2 ADJUSTING HEAD HEIGHT

4D.2.1 Record/Reproduce Heads (Not 1/4-Track))

Adjust head height as follows:

Step 1: Remove the head housing cover by disengaging the captive screw on the angled back surface.

Step 2: Thread tape on transport, and initiate the play mode at the highest speed available.

Step 3: Loosen two nuts (items 42 and 43, Fig. 6-1) approximately 1/4 turn.

Step 4: Turn the two hex-socket setscrews (see Fig. 4D-1) clockwise the same number of turns, until the head laminations barely appear at the tape bottom edge.

Step 5: Carefully count the turns, while turning the two hex-socket setscrews counterclockwise (in exactly equal turns) until the head laminations barely appear above the tape top edge.

Step 6: Turn the same two setscrews back half the number of turns counted in Step 5. Turn the two nuts loosened in Step 3 clockwise until they are snug.

Step 7: Stop tape motion.

Step 8: Check head zenith and tape wrap per paragraph 4D.3. Check head azimuth per paragraphs 4C.3.6 and 4C.3.8.

Step 9: Replace head housing cover.

4D.2.2 Quarter-Track Record/Reproduce Heads

To set the height of a quarter-track record or reproduce head: repeat Steps 1, 2, and 3, paragraph 4D.2.1; then adjust the two hex-socket setscrews so that the mu-metal portion of the outermost head is exactly even with the outermost edge of the tape.

4D.2.3 Erase Heads

Erase head height is adjusted with shims (0.010, 0.002, 0.003, and 0.005 inch thick, Ampex Part Nos. 4350025-01, 4350025-02, 4350025-03, and 4350025-04 respectively). To change shims, the head must be removed by removing one cross-head screw (item 40, Fig. 6-1; or item 31, Fig. 6-3).

Except for quarter-track erase heads, shim the heads until the ferrite portion of the outermost head is just visible at the outermost edge of the tape. Add shims until the similar portion of the bottom head is barely visible below the tape bottom edge. Then remove exactly half the shim thickness needed to move the head stack from the top to bottom of the tape.

If a quarter-track erase head is used, use shims to position the ferrite portion of the outermost head even with the outermost edge of the tape, then remove shims to raise the head 0.006 inches. (The erase head is wider than the record or playback heads, so it must be positioned above the outermost edge of the tape.)

4D.3 ADJUSTING TAPE WRAP AND ZENITH

The head gap must be centered in the tape contact area, and the tape must contact the head top and bottom equally.

To check tape wrap and head zenith, lightly cover the head face with grease pencil or crayon. Thread tape on transport, initiate the high speed play mode, and stop it after ten seconds. Lift the tape from the head, the head area visibly cleaned by the tape should be centered on the head gap (this checks tape wrap). The head tape-contact area should also be equally clean at the top and bottom (this checks head zenith).

If tape wrap adjustment is indicated, remove the head housing cover by disengaging the captive screw on the angled back surface. Loosen the large cross-head screw (item 40, Fig. 6-1; or 31, Fig. 6-3). Beneath the mounting screw there is a smaller cross-head screw in a hole. Loosen the small cross-head screw, and carefully use a screwdriver to pry at the side of the head stack (not the shield) in the required direction. Check that the shield is aligned with the head gate shield then tighten the screws. Recheck the tape wrap per the preceding paragraph. Repeat the process until the tape wrap is correct. The erase head is adjusted for tape wrap by loosening the mounting screw, rotating the head as required, and tightening the screw.

To adjust the head zenith, use the two hex-socket setscrews (also used for head height adjustment, see Fig. 4D-1). As the adjustment is being made, visually check the zenith by lining up the head with the capstan or the scrape-flutter idler. Turn the outermost setscrew in and the innermost setscrew out, to move the stack bottom in (away from the tape). To move the bottom of the head out (toward the tape), reverse the procedure. Be sure both setscrews remain snug. When the zenith adjustment seems correct, recheck it with the grease pencil method described above. Repeat the adjustment until the head zenith is correct (no zenith adjustment is required for the erase head).

Whenever head zenith or tape wrap is changed, check the head azimuth and height per paragraphs 4C.3.6, 4C.3.8, and 4D.2.

4D.4 CHANGING HEAD STACKS

4D.4.1 Record or Reproduce Stack

Step 1: Remove the complete head assembly per paragraph 4A.2.3.

Step 2: Remove the large cross-head screw (item 41, Fig. 6-1; or item 31, Fig. 6-3) and then the shield (containing the head stack).

Step 3: If the replacement head stack is in a shield, mount the shield in position. Check (through the bottom of the casting) that the head stack shield is aligned with the head shield, and is parallel to the casting top front edge, then

tighten the mounting screw.

Step 4: If the head stack is not in a shield, use a screwdriver to remove the two slot-head screws and the nuts (items 39-42 and 39-43, Fig. 6-1; or items 30-32 and 30-33, Fig. 6-3) and remove the head stack from the shield. Be careful not to lose the double-coil lockwasher. Remove head stack and two head springs (item 3, Fig. 6-1 and Fig. 6-3) from the shield. Unsolder the leads at the head stack.

Step 5: Pass the leads from the connector assembly through the hole in the back of the shield, and solder them to the terminals on the new head stack as shown in Figs. 6-2, 6-3, or 6-5.

Step 6: Turn the two hex-socket setscrews out until the ends are even with the inside of the shield.

Step 7: Obtain the two slot-head screws and the nuts removed in Step 3. Turn the nuts tightly against the screw heads. Place the double-coil lockwasher over the end of the screw with the plain hex nut (the other screw has a self-locking nut).

Step 8a: On heads for 1/4-inch tape, place the two head-springs in the indentations in the top of the head stack. Slip the head stack into the shield without displacing the springs.

Step 8b: On heads for 1/2-inch tape, hold the shield upside down, and place the two head-springs in the indentation in the shield (looking through the shield open side, the indentations are at the right front and right rear). Without displacing the springs, slide the head stack (upside down) into the shield.

Step 9: Insert the two slotted-head screws through the plate and shield, along with the screw, plain hex nut, and double-coil lockwasher, in the position shown for items 39 and 42, Fig. 6-1; or items 30 and 32, Fig. 6-3. Engage the two screws in the head stack holes, and tighten them firmly.

Step 10: Secure the head stack and shield in the head assembly with the large cross-head screw removed in Step 2. Check (through

the bottom of the casting) that the head stack shield is aligned with the head shield, and is parallel to the casting top front edge, then tighten the mounting screw.

Step 11: Turn-in the two hex socket-head setscrews to lower the head stack, until head height is approximately correct.

Step 12: Turn the two nuts on the cross-head screws down against the plate, and use the azimuth-adjusting nut (see Fig. 4C-6) to set the head azimuth to the approximate correct position.

Step 13: Install head assembly on the transport and mate the connectors with the correct receptacles (see Fig. 4A-1).

Step 14: Check and adjust head height per paragraph 4D.2; tape wrap and zenith per paragraph 4D.3; and head azimuth per paragraph 4C.3.6 (reproduce) or 4C.3.8 (record).

4D.4.2 Erase Head Stack

To change an erase head stack, remove the complete head assembly from the transport. Remove the large cross-head screw (item 40, Fig. 6-1, or 31, Fig. 6-3), then remove the erase head stack, spacer, and shims.

Place the spacer and shims on the new assembly and mount them on the casting with the mounting screw. Check erase head height per paragraph 4D.2.3, and the tape wrap per paragraph 4D.3.

4D.5 TAPE SKEW CHECKOUT

To check tape skew, play back the 15-Hz tone on a 7-1/2 ips Ampex Standard Test Tape, then adjust the reproduce level control for a convenient VU meter indication. Manually stall the reel idler, then the scrape-flutter idler, the VU meter indication should not drop over 1 dB in either case.

To correct excess drop, check that the tape guides (in the tape housing) are set 0.750 inch from the top of the transport stainless-steel overlay, then adjust reproduce head azimuth per paragraph 4C.3.6. Recheck tape skew by

manually stalling reel idler and the scrape-flutter idler; if the meter indication is still outside of tolerance, proceed as follows:

Step 1: Loosen the two tape-guide mounting screws on the reproduce side of the head assembly (item 37, Fig. 6-1; or item 29, Fig. 6-2) so they will maintain the guide position, but can be moved.

Step 2: Adjust the tape guide very slightly up or down, then repeat the tape skew check. If the high frequency drop is still not within tolerance, move the tape guide in minute increments until tape skew is corrected. Tighten the guide mounting screws, then adjust head azimuths per paragraphs 4C.3.6 and 4C.3.8.

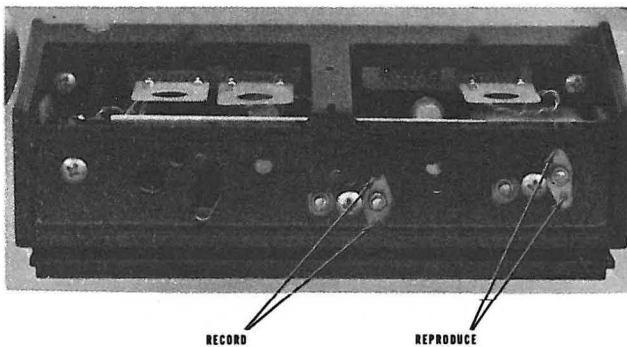

Fig. 4D-1. . Head Height and Zenith Adjustments

Section 4

MAINTENANCE**Part E. Transport Maintenance****4E.1 GENERAL**

The following paragraphs contain transport corrective maintenance, parts replacement, and the special adjustment procedures required thereafter. Most of these procedures require removal of the console front panel per paragraph 2.3.

NOTE

Transport preventive maintenance procedures (cleaning, lubricating, etc.) are in part B of this section, and normal checkout and adjustment procedures are in paragraph 4C.2.

4E.2 SERVICING HINTS**4E.2.1 Brake Bands**

Glazed brake bands that are not contaminated with oil can sometimes be renovated by abrading them only with sandpaper 4.0 grit or finer. Do not use emery cloth or carborundum-coated paper.

4E.2.2 Solenoids

A corroded solenoid plunger, which doesn't slide freely, can be renovated by rotating it in a drill press while holding crocus cloth against it.

CAUTION

Do not lubricate plungers, since oil can eventually cause sticking.

4E.2.3 Relays

To visually check if a relay is energizing, remove the snap-on cover with a thin-blade tool. Rub any contaminated relay contacts clean with bond paper or a relay-contact burnishing tool.

Since most relays are identical, play/record operations may be continued in an emergency by interchanging a defective play/record relay with a sound fast-forward, rewind, or edit relay (depending on importance of the function).

4E.2.4 Capstan Idler

The capstan idler (item 90, 91, Figure 6-8) is removed from idler arm (39) by loosening setscrew (75). No other parts of the idler arm assembly are replaceable (refer to paragraph 4E.8.2).

4E.3 HEAD-CABLE AND POWER-SUPPLY BOXES REPLACEMENT

The head-cable and power-supply boxes must sometimes be removed during corrective maintenance procedures.

4E.3.1 Head-cable Box

Remove and install the head-cable box per paragraph 4A.2.4.

4E.3.2 Power Supply Removal

To remove the power supply, disconnect cables from receptacles J701 through J704. Disconnect the captive power-supply cable from the receptacle on the transport control box. Remove the four mounting screws and remove the power supply box.

CAUTION

A power transistor is mounted on the side of the power supply, next to the transport. Use care not to damage the transistor while removing the power supply.

4E.3.3 Power Supply Installation

Install the power supply in reverse order to removal procedures. (The captive cable is routed from under the power supply box, out of the side toward the transport control box.)

4E.4 TAKEUP AND REWIND ASSEMBLIES

4E.4.1 General

Major components in the takeup and rewind assemblies are the torque motor and the brake. The turntable and brake drum (fixed to the motor shafts) cannot be adjusted or individually replaced. The fixed position of the turntable also prevents removal of the motor flange. If any of these three components are damaged beyond use, the complete motor assembly must be replaced.

The takeup and rewind assembly drawings are shown in Figs. 6-12 and 6-13.

Adjustment of tape tension (motor torques) and braking force are given in paragraphs 4C.2.3 and 4C.2.4.

4E.4.2 Replacing Takeup or Rewind Assembly

The takeup and rewind assemblies are each secured, through slotted holes in the top plate, to the reel guards (for quick conversion to 11-1/2-inch CCIR reels). When either assembly is removed, the reel guard will also be released.

To remove either assembly, disconnect the connector from the tape transport, slide the plastic sleeving from the capacitor solderless connectors and disconnect them. Manually support the assembly, and remove the three nuts and washers (items 77 and 79, Fig. 6-9) from the assembly and the reel guard. Remove the reel guard, then guide the turntable through the top plate hole and remove the assembly.

Reinstall the assembly in the reverse order of removal procedures. If the 10-1/2-inch NAB reel is the largest to be used, secure the assembly in the innermost position. If the 11-1/2-inch CCIR reel is to be used, secure the assembly in the outermost position. Before tightening the mounting nuts, check that the flat portion of the reel guard is parallel with the transport top edge (see Fig. 6-8) and that the turntables are centered in the guard. Connect the leads to the motor capacitor as shown in Fig. 6-12 (takeup assembly) or 6-13 (rewind assembly).

4E.4.3 Reel Drive Plate Replacement

A reel drive plate (item 4, Fig. 6-12), in the center of each turntable, has three extrusions which mate with the EIA reel hubs. Three screws secure the plates to the turntable. To replace the drive plate, remove the three screws, lift the plate from the spindle, place the new drive plate in position, and reinstall the screws.

4E.4.4 Turntable Pad Replacement

To replace the cork pad (item 3, Fig. 6-12) on the turntable top, use a putty knife (or similar tool) to lift one edge of the pad, then peel it off the turntable. Clean all adhesive from the turntable, with lacquer thinner, MEK, or similar solvent. Peel the backing from the new pad (exposing the adhesive surface) and carefully align the reel holddown holes in the pad with those in the turntable. Press the pad firmly in position.

4E.4.5 Brake Assembly Removal (See Figure 6-12)

Remove cable clamp which secures the wires to the solenoid bracket. Slide the plastic sleeving from the solderless connectors on the two solenoids, and disconnect the wires. Remove the three screws (item 9, Fig. 6-12), then manually actuate the main brake solenoid (the one closest to the motor) and slide the entire assembly from the brake drum.

Install the brake assembly per paragraph 4E.4.8.

4E.4.6 Brake Band Replacement (See Figure 6-14)

Remove the brake assembly from the takeup or rewind assembly per paragraph 4E.4.5, then proceed as follows to replace the brake band:

Step 1: Remove the brake spring (item 11, Fig. 6-14).

Step 2: Remove the two socket-head cap-screws and washers, below item 27, Fig. 6-14, which secure the brake band (at the end farthest from the solenoids). A band link clamp will also be released.

Step 3: Loosen (do not remove) the two socket-head cap-screws at the other end of the brake band. Take care not to lose the leaf spring, then slide the brake band end from between the clamp and the screws, and remove the brake band.

Step 4: Insert the new brake band through the holes in the housing, with the slotted end toward the solenoids.

Step 5: Secure the brake band end, farthest from the solenoids, with the band link clamp, the two socket-head cap-screws, and the lockwashers removed in Step 2.

Step 6: Insert the brake band's slotted end between the band link and its clamp. Install the leaf spring between the brake band and the band-link clamp (so the spring is on the band inner side, which is on the same side as the lining). Tighten the two socket-head cap-screws snugly, but so the brake band will still slide in and out of the clamp.

Step 7: Reinstall the brake spring removed in Step 1.

Step 8: Adjust the brake assembly per paragraph 4E.4.8.

4E.4.7 Brake Solenoids Replacement (See Figure 6-14)

Remove cable clamp which secures the wires to the solenoid bracket. Slide the plastic sleeving from the solderless connectors on the two solenoids, and disconnect the wires.

To remove the edit brake solenoid (the one farthest from the motor) remove the two screws and washers (items 29 and 38, Fig. 6-14). These screws and washers are used in four places; remove the two from the edit solenoid and its bracket (item 7 or 8, Fig. 6-14; the solenoid plunger will slide partly out. If the plunger must be removed, remove the self-locking nut (item 37, Fig. 6-14) and the spring beneath it, and slide the spade bolt (item 34, Fig. 6-14) out through the hole in the edit-solenoid stop-plate (item 18, Fig. 6-14). Remove the plunger from the spade bolt by removing the cotter pin and clevis pin (items 24 and 25, Fig. 6-14).

To remove the main brake solenoid, remove the two screws and washers (items 29 and 38, Fig. 6-14). These screws are used in six places, remove the two from the main brake solenoid and the edit solenoid bracket (item 7, Fig. 6-14). Remove the two screws (item 31, Fig. 6-14) from the end of the main brake solenoid and the solenoid bracket (item 6, Fig. 6-14). Pivot the edit brake solenoid bracket for access, then remove the main brake solenoid (the plunger slides partly out of the solenoid). If the plunger must be removed, remove the cotter pin and clevis pin (items 24 and 25, Fig. 6-14).

Replace the solenoids in the reverse order to removal procedures. Check that both solenoids faces are aligned with the edit solenoid bracket. Perform adjustment procedures given in paragraph 4E.4.8.

4E.4.8 Brake Installation and Adjustment (See Figures 6-10 and 6-12)

To replace the complete brake assembly on the reel motor, manually actuate the main brake solenoid, insert the brake band over the brake drum on the motor shaft, and secure the assembly in position with the three screws (item 9, Fig. 6-12).

After installing any item on the brake assembly, adjust the brakes as follows:

NOTE

Parts that are adjusted are illustrated in the takeup and supply brake adjustment portion of Fig. 6-10.

Step 1: Check that the edit-brake solenoid is flush with the edit solenoid bracket. Adjust the edit solenoid bracket so it is 1/16 inch above the inboard face of the main-brake solenoid.

Step 2: Move the edit-solenoid spring-anchor fully forward.

Step 3: Manually actuate the main-brake solenoid, and measure the plunger protrusion

from the solenoid in its bottomed position.

Step 4: Check that the brake band is correctly aligned to the drum. Slide the slotted end of the band (see Fig. 6-10) into its clamp until the main-brake solenoid plunger is 5/32 to 3/16 inch from the fully-bottomed position measured in Step 3 (solenoid not actuated). Secure the band in that position by tightening the two socket-head capscrews.

Step 5: Manually actuate the main-brake solenoid and check that the brake band does not buckle (buckling will be visible near the brake band adjustment point). If buckling is evident, slide the band end into the clamp just to the point where buckling is removed.

Step 6: Manually actuate the main brake solenoid. Rotate the motor and check for the band dragging on the brake drum. If dragging is noted, the band was shortened too much in Step 5, and must be lengthened by sliding it out of the clamp. The final adjustment must result in no band buckling or drag, with the solenoid fully bottomed.

Step 7: Position the edit-solenoid spring-anchor so the edit-solenoid stop-plate clears the main-brake solenoid plunger by 1/16 ($\pm 1/64$) inch, then secure the anchor in that position.

Step 8: Connect the solderless connectors to the solenoids and slide the plastic sleeving over the connectors.

Step 9: Using cable clamps, secure all leads to the solenoid bracket (item 6, Fig. 6-14) and away from rotating parts.

Step 10: Adjust the main brake and edit brake per paragraph 4C.2.4.

4E.4.9 Motor Capacitor Replacement (See Figure 6-9)

To remove a takeup or rewind motor capacitor (item 22, Fig. 6-9) remove the power supply per paragraph 4E.3. Slide the plastic sleeving from the solderless connectors on the capacitor leads, and disconnect the wires. Loosen the two screws on the mounting plate (item 42,

Fig. 6-9), and slide the capacitor and plate from the casting. Remove the mounting plate and use the removed screws, nuts, and washers to secure the new capacitor on the plate (do not tighten the screws). Slide the capacitor and plate into position, then tighten the screws. Connect the leads (see Figs. 6-12 for takeup; or 6-13 for rewind) and reinstall the power supply.

4E.5 DRIVE MOTOR

4E.5.1 Lubrication

Drive motor lubrication is given in paragraphs 4B.3.1, 4B.3.2, and 4B.3.3.

4E.5.2 Fan and Flywheel Replacement

The fan and the flywheel are secured to the drive motor shaft by setscrews. To remove the components, loosen the setscrews and slide the parts off the shaft.

To reinstall the components, slide the flywheel on the shaft until the hub is against the shaft shoulder (the hub setscrew portion should be away from the motor). Tighten the setscrew against the shaft flat. Slide the fan on the shaft (setscrew side toward the motor) and bottom it against the flywheel hub. Tighten the setscrew against the shaft flat.

4E.5.3 Drive Motor Replacement (See Figures 6-8 and 6-9)

CAUTION

Do not bump or scrape the capstan as the motor is removed or installed.

To remove the drive motor, disconnect the drive motor cable from the tape transport. Remove the transport capstan idler (item 4, 5, Fig. 6-8) by loosening the setscrew (item 75, Fig. 6-8) and lifting the idler from the arm (item 39, Fig. 6-8). Manually support the drive motor, and remove the four screws (item 60, Fig. 6-8) from the motor and the top plate (the motor shield is also released).

Install the drive motor in the reverse order of removal procedures. Be sure to

reinstall the motor shield (item 37, Fig. 6-9) as pictured. Install the capstan idler so that the top of the rubber tire is $1/32$ ($\pm 1/64$) inch below the capstan shaft end.

4E.5.4 Motor Capacitor Replacement (See Figure 6-9 and 6-10)

The drive motor capacitor (item 13, Fig. 6-9) is secured by two screws to the capstan solenoid-mounting plate (item 43, Fig. 6-9). Slide the plastic sleeving from the solderless connectors on the capacitor leads, and disconnect the wires. Use a short screwdriver (or offset screwdriver) to remove the two screws and washers (items 69 and 80, Fig. 6-9) and remove the capacitor. Use the removed screws and washers to mount the new capacitor in position, and reconnect the leads as shown in Fig. 6-10.

4E.6 REEL IDLER

4E.6.1 Tape Guide Replacement (See Figure 6-15)

To remove the tape guide from the reel idler arm, unscrew the spring-loaded screw (item 9, Fig. 6-15), then remove the guide, the idler, screw, spring, and flat washers (used as shims). To install the tape guide, insert the spring and screw in the top of the guide, and install all of the washers; seat the guide slot (in the bottom) over the spring pin on the arm, and tighten the screw.

4E.6.2 Pulley Replacement (See Figure 6-15)

The pulley is held in the reel idler housing by the reel idler flywheel, which is secured to the pulley shaft by a setscrew. The setscrew is in the side of the flywheel toward the transport, and must be found by feel. Rotate the flywheel so the pulley shaft flat is toward the outer edge of the rewind motor. Insert a $3/32$ Allen wrench (with a handle and long-shaft) past the outer edge of the rewind motor, and then into the setscrew hole by feel. If the transport is face down, manually support the reel idler pulley while loosening the setscrew and removing the flywheel, then slide the pulley out of the housing.

Install the pulley by sliding the pulley shaft back through the housing, and then remounting the flywheel. End play must be 0.003-0.005 inch to avoid damaging the ball bearings.

Check the play by firmly holding the pulley down in the housing and using a feeler gauge between the pulley and the housing (at the side opposite the arm). To this measurement add 0.004 inch, and select the feeler gauge leaves equal to the total. Insert the gauge between the pulley and housing, at the side opposite the idler arm. Hold the pulley firmly down on the gauge, and push the flywheel (setscrew side in) so it firmly contacts the bottom of the housing. Tighten the flywheel setscrew, and remove the feeler gauge.

4E.6.3 Idler Tension Adjustment (See Figure 6-15)

The idler tension is not critical; however, if it becomes too high, and cannot be correctly adjusted, it indicates that reel idler damage is causing binding.

Measure the force at the outer end of the arm with a spring scale. Approximately two ounces of pressure should be required to move the arm from its stop.

If adjustment is indicated, remove the pulley assembly per paragraph 4E.6.2, which reveals two screws (item 21, Fig. 6-15). Loosen the screws, and rotate the bushing (item 2, Fig. 6-15) clockwise to increase pressure, or counterclockwise to decrease pressure. Tighten the two screws, and recheck the spring force. Repeat the procedure until force is approximately 2 ounces.

Reinstall the pulley per paragraph 4E.6.2.

4E.6.4 Arm Assembly Replacement (See Figure 6-15)

To remove the arm assembly, remove the pulley per paragraph 4E.6.2, then remove the two screws (item 21, Fig. 6-15). Remove the arm, bushing, and idler mount (items 5, 2, and 8, Fig. 6-15) from the housing. The arm is between the bushing and the mount; they are press-fit together to a very close tolerance and, therefore, cannot be ordered separately. Contact Ampex Audio Technical Support Department if replacement is required. The tension spring can easily be replaced by unhooking it from two pins, one on the arm and the other on the mount.

To install the arm assembly, insert it in the housing with the arm in the upper left slot. Install the two screws loosely, then check and adjust arm tension per paragraph 4E.6.3. Replace the pulley per paragraph 4E.6.2.

4E.6.5 Reel Idler Replacement (See Figure 6-9)

To remove the reel idler, remove the pulley per paragraph 4E.6.2. At the back of the tape transport, two screws and washers (items 66 and 85, Fig. 6-9) secure the reel idler to the casting. Manually support the reel idler, remove the screws, and remove the idler from the transport.

Install the idler in the reverse order of removal procedures. If the arm was removed from the housing, check and adjust the arm tension per paragraph 4E.6.3. Install the pulley per paragraph 4E.6.2.

4E.6.6 Ball Bearing Replacement (See Figure 6-15)

To replace the ball bearings (item 17, Fig. 6-15) in the reel idler, remove the idler from the transport per paragraph 4E.6.5. Remove the arm from the housing per paragraph 4E.6.4. Insert a pencil (or similar object) up through the hole in the lower bearing to push the top bearing out.

To remove the lower ball bearing, use Truarc pliers to remove the lower retaining ring, then insert the pencil (or similar object) from the top of the housing to push the bearing out.

CAUTION

When installing the new bearings, use no lubrication. Insert the bearings into the housing with finger pressure only, being very careful not to cock the bearings in the housing.

Install the lower bearing, against the retaining ring, by pushing only on the bearing outer race (not toward the inside) with equal pressure on opposite sides of the bearing. Install the lower retaining ring below the bearing,

then push the other bearing into position.

Mount the idler housing on the transport, and install the arm assembly. Check and adjust the arm tension per paragraph 4E.6.3. Install the pulley per paragraph 4E.6.2.

4E.7 TAKEUP TENSION ARM

4E.7.1 Arm Spring Adjustment

This adjustment is always required if the transport mounting is changed between the horizontal and vertical positions.

To check force on the takeup tension arm, use a spring scale to measure the tension at the tape guide on the arm outer end. With the scale, pull the arm so the arm centerline is parallel to the transport bottom edge. The scale should indicate from 1/4 to 3/8 ounce (7 to 11 grams).

To adjust the tension, remove the socket-head screw from the cover cap, then remove the cover cap from the tension arm base. A spring wound around the bushing (below the arm) has one end in a hole in the bushing. The other spring end is hooked to one of two pins that are 180° apart and upright on the base. Adjust the tension by using a soldering aid (or similar tool) to move the spring hook progressively from one pin to the next until the correct force is obtained. A spacer beneath the spring hook must also be moved. Wind the spring tighter around the bushing to increase force, or loosen it to decrease the force.

4E.7.2 Safety Switch Adjustment

To check the position where the takeup tension arm actuates the safety switch (to stop tape motion) move the arm to the tape threaded position. Allow the arm to return slowly toward the rest position, listening closely for the click when the safety switch actuates. At that point, the tape guide tape-contacting surface should be 3-3/4 (+0, -3/4) inch from the transport bottom edge.

Required adjustments are made from the transport back. Remove the connectors for drive and takeup motors from the transport con-

trol box. Hold other wires aside so the safety switch (item 23, Fig. 6-9) is accessible. Use long-nose pliers to bend the safety switch spring actuator out from the switch to actuate with the takeup tension arm higher; and toward the switch for a lower position. Reconnect the drive motor and takeup motor connectors.

4E.7.3 Tape Guide and Hook Replacement

Remove the tape guide and hook from the takeup tension arm by removing the spring-loaded screw from the top of the guide.

To install the hook and guide, use the spring pin to mate the hook locating hole to the guide bottom slot, with all shim washers repositioned between the guide and hook. Insert the spring and screw in the guide, then tighten the screw in the arm.

4E.7.4 Tension Spring Replacement

To replace the tension spring around the bushing, remove the base cap by removing the socket-head screw in the cap. Unhook the spring end from the pin, and allow it to unwind. Remove the spring straight end from the bushing hole. Use long-nose pliers to start the spring's top end over the arm, then unscrew the spring from the bushing.

To install the spring, start the straight end onto the bushing and screw it on. Insert the spring straight end into the hole in the bushing base; tighten the spring, by winding the hook end around the pins two or three times; then hook the end to one of the pins on the base. Check and adjust the arm spring force per paragraph 4E.7.1.

4E.7.5 Takeup Tension Arm Replacement (See Figure 6-9)

Replacement of replaceable parts of the takeup tension arm assembly is given in paragraphs 4E.7.3 and 4E.7.4. If any other component is defective, the complete assembly must be replaced.

To remove the takeup tension arm assembly, disconnect the drive-motor and takeup-motor cables from the transport. Secure other wires aside for access to the tension arm base.

Remove one screw (item 68, Fig. 6-9), and lift the assembly off the transport, while carefully guiding the drive pin (protruding from the assembly inner end) out through the top plate.

Remove the setscrew (item 73, Fig. 6-9) from the base, and install it in the new assembly so it protrudes 3/16 inch. Guide the end of the new assembly through the top plate hole and mate the setscrew with the upper left hole. Secure the assembly to the transport with the removed setscrew.

Check and adjust the safety switch actuation per paragraph 4E.7.2. Reconnect the drive-motor and takeup-motor cables to the transport control box.

4E.8 CAPSTAN IDLER

4E.8.1 Lubrication and Adjustment

Lubrication of the capstan idler is given in paragraph 4B.3.3. The adjustment of idler force against the capstan is given in paragraph 4C.2.5.

4E.8.2 Parts Not Removable

The capstan idler arm (item 39, Fig. 6-8) and associated components cannot be removed from the transport, because the solenoid arm (item 33, Fig. 6-9) is secured to the idler arm shaft by a press-fit rollpin. Removing and installing this rollpin requires special tools. The solenoid arm will not pass through the hole in the transport, so parts between the idler arm and the solenoid arm cannot normally be removed. If any of these parts should ever require replacement, the transport should be returned to the factory for repair.

CAUTION

Do not use a drift pin and hammer to drive the rollpin out or in, since irreparable transport distortion can result.

4E.8.3 Idler Positioning (See Figure 6-9)

The normal clearance between the idler tire and the capstan should be 1/2-5/8 inch.

To adjust the clearance, loosen the two screws securing the stop to solenoid (item 9, Fig. 6-9). Slide the stop to the position that provides correct clearance, then tighten the screws. Check and adjust the capstan idler pressure per paragraph 4C.2.5.

4E.8.4 Idler Replacement (See Figure 6-8)

The rubber-tired idler (item 4, 5, Fig. 6-8) is held on the idler arm (item 39, Fig. 6-8) by a setscrew (item 75, Fig. 6-8). To remove the idler, loosen the setscrew and slide the idler shaft from the arm.

Install the idler so the tire top surface is 1/32 ($\pm 1/64$) inch below the capstan top surface, then tighten the setscrew.

4E.8.5 Capstan Solenoid Replacement (See Figure 6-9)

To remove the capstan solenoid (item 9, Fig. 6-9) remove the drive motor (with capacitor) per paragraphs 4E.5.3 and 4E.5.4. Disconnect the takeup motor cable from the transport control box. Remove the self-locking nut and the adjustment spring from the end of the bolt in the solenoid arm (item 33, Fig. 6-9). Slide the plastic sleeving from the solderless connectors on the solenoid leads, and disconnect them. Remove the mounting plate that clamps the solenoid to the transport by loosening the four screws (items 63 and 67, Fig. 6-9). Slide the plate and solenoid off, while guiding the bolt out of the solenoid arm.

To install the solenoid, loosely secure the mounting plate to the solenoid with the four removed screws and washers. (The solenoid leads are fastened in a cable clamp (item 58, Fig. 6-9) that is secured with one screw (item 67, Fig. 6-9)). Place the solenoid return spring on the bolt as shown in Fig. 6-9, then insert the bolt end through the solenoid arm (item 33, Fig. 6-9). Slide the plate and solenoid over the casting extrusions. Tighten the screws to clamp the solenoid in position. Install the solenoid adjusting spring, and then the self-locking nut on the bolt. Connect the leads to the solenoid. Install the drive motor and its capacitor per paragraphs 4E.5.3 and 4E.5.4, respectively. Reconnect the takeup motor cable. Check and adjust the cap-

stan idler per paragraph 4E.8.3. Check and adjust the capstan idler pressure per paragraph 4C.2.5.

4E.9 TAPE LIFTER

4E.9.1 Adjustment Procedure (See Figure 6-10)

During the play mode, the tape lifter arms must not touch the tape. In either fast-wind mode, the lifter must remove the tape from head contact; however, the tape must not contact the head gate shield covers. Adjustment is usually required only when a tape lifter component, or the solenoid is replaced.

To adjust the tape lifter, remove the reel idler flywheel and pulley per paragraph 4E.6.2. Disconnect the transport rewind-motor and power-supply cables. Remove the dummy plugs (or cables) from the 60-Hz-amplifier and remote-control receptacles, and remove the four transport plug-in relays. If head cables are in the way, move them to one side. Refer to the tape lifter portion of Fig. 6-10, then proceed as follows:

Step 1: Loosen the two stop screws and position the stop 21/32 inch from the solenoid face. Tighten the two screws (this position may have to be re-adjusted later).

Step 2: Loosen the hex-head screw at each end of tape lifter bracket. Slide bracket fully toward solenoid. Insert tape lifter spring (between solenoid plunger link, and tape lifter bracket) and hook it in nearest tape lifter bracket hole that doesn't require stretching of spring (usually third or fourth hole from solenoid).

Step 3: Hold either tape lifter arm so there is a 1/16-inch clearance between it and the back of the slot (see Fig. 6-10). Slide tape lifter bracket away from solenoid until all slack is removed from the tape lifter spring, the solenoid plunger link, and the plunger (plunger must be fully against stop). Tighten the two hex-head screws to secure the tape lifter bracket.

Step 4: If slack is not removed, slide tape lifter bracket toward solenoid, and move tape lifter spring hook to the next hole in the bracket. Then repeat step 3.

Step 5: Manually move solenoid plunger to fully-bottomed position. Tape lifter arm should move to 1/16 inch from other end of slot.

Step 6: If clearance is not 1/16 inch, reposition the tape lifter solenoid stop from the 21/32 inch clearance set in step 1 (move stop farther from solenoid face for more arm travel, or closer for less travel; adjustment is a 2:1 ratio, so moving the solenoid stop 1/16 inch will change arm travel by 1/8 inch). If the solenoid stop is repositioned, steps 2 through 5 must be repeated until the final adjustment results in a 1/16 inch clearance between the arm and each end of the slot (with solenoid deenergized, then energized).

Step 7: Replace the reel idler pulley and flywheel per paragraph 4E.6.2. Connect all cables, and reinstall relays and dummy plugs on the transport control box.

4E.9.2 Solenoid Replacement (See Figures 6-9 and 6-10)

To remove the tape lifter solenoid, remove the reel idler pulley and flywheel per paragraph 4E.6.2. Disconnect the rewind-motor and electronic-power-supply cables from the transport control box. Remove tape lifter spring (refer to Fig. 6-10). Slide the plastic sleeving from the solderless connectors on the solenoid leads and disconnect the wires. The solenoid (item 10, Fig. 6-9) is clamped to the transport casting by a mounting plate (item 41, Fig. 6-9). Use an open-end wrench to loosen the two hex-head screws (item 62, Fig. 6-9), then slide solenoid and plate off.

To install the solenoid, mount the plate on the solenoid end with the two removed screws, lockwashers, and flat washers (items 62, 84, and 88, Fig. 6-9). Slide the solenoid and plate onto the extrusions on the casting, and use an open-end wrench to tighten the two mounting screws. Connect the leads to the solenoid, and reinstall the tape lifter spring in its original position. Adjust tape lifter action per paragraph 4E.9.1. Reinstall the reel idler pulley and flywheel per paragraph 4E.6.2, and reconnect cables.

4E.9.3 Tape Lifter Replacement (See Figures 6-9 and 6-11)

To remove the tape lifter assembly, remove the reel idler pulley and flywheel per paragraph 4E.6.2. Disconnect the transport rewind-motor and power-supply cables, remove the dummy plugs (or cables) in the 60-Hz-amplifier and remote-control receptacles, and remove the four plug-in relays.

Remove the tape-lifter solenoid per paragraph 4E.9.2. Remove the tape-lifter return spring (item 35, Fig. 6-9) from between the tape lifter assembly and the transport post. Remove the two socket-head shoulder screws (item 44, Fig. 6-9), and remove the complete assembly (note that flat washers, item 83, Fig. 6-9, are between the tape lifter and the transport).

The tape lifter assembly drawing is provided in Fig. 6-11. Replaceable parts are listed in the tape transport parts list. The spring (item 5, Fig. 6-11) takes up slack at the end of the clevis pins on the tape lifter arms, to prevent backlash and rattle.

To install the tape lifter assembly, reverse the removal procedures. Be sure to install the washers (item 83, Fig. 6-9) between the assembly and the transport. Install the tape lifter solenoid per paragraph 4E.9.2. Adjust the tape lifter action per paragraph 4E.9.1. Reinstall the reel idler pulley and flywheel per paragraph 4E.6.2. Reinstall the connecting cables, dummy plugs, and relays.

4E.10 SAFETY SWITCH (See Figures 6-7, 6-9, and 6-10)

To remove the safety switch (item 23, Fig. 6-9), disconnect the drive-motor and takeup-motor cables from the transport control box. Move other wiring aside for access. Slide the plastic sleeving from the solderless connectors on the safety switch leads and disconnect the wires. The switch is secured to mounting posts on the transport casting, by two screws and washers (items 70 and 82, Fig. 6-9). Remove these screws and the switch, along with the shield (item 30, Fig. 6-7).

To install the safety switch, place the shield over the switch, then use the removed two screws and washers to secure them to the casting. Connect the leads to the switch as shown in Fig. 6-10. Check and adjust safety switch actuation per paragraph 4E.7.2. Connect the drive-motor and takeup-motor cables to the transport control box.

4E.11 SERVICING PROCEDURES

4E.11.1 General

Tape transport power distribution (to three motors, and six solenoids) is controlled by transport control box components, including switches, relays, fuses, switching transistors, and the power supply.

The tape transport schematic diagram is provided on Fig. 6-20. A simplified schematic, Fig. 6-21, shows the three main control circuits, one of which routes all ac line-power to the electronic power supply, the takeup and rewind motors, the drive motor, the 24-volt dc supply, and the 115-volt dc supply.

The 24-volt dc supply furnishes power for the relays (play, edit, fast forward, rewind, and record relays) and the tape lifter solenoid. Two switching transistors are in the 24-volt dc circuit. The 115-volt dc supply powers the solenoids for the capstan, the two main brakes, and the two edit brakes.

Assembly drawings for the transport control box are provided in Figs. 6-17 and 6-19. A power distribution and fusing diagram is shown in Fig. 6-19.

4E.11.2 Control Box Bottom Cover Removal

The control box bottom cover must be removed for access to components inside. To remove the cover, turn power OFF, and remove the cover over the tension-adjust resistors, with the two mounting nuts (one at each end). Use an open-end wrench to loosen the seven hex-head screws (two at each end, and three on one side of the bottom cover). Use the access finger holes to pull the cover off (the screws slide out of slots on the box).

WARNING

Dangerous voltages are present inside the control box and across the tension-adjust resistors when power is applied. Only thoroughly experienced personnel should attempt to service the unit with power on.

4E.11.3 Control Box Removal

To remove the control box, disconnect all cable connectors. Disconnect the solderless connectors from the tape lifter solenoid, the capstan solenoid, the drive motor capacitor, and the safety switch (slide the insulation off connectors before disconnection).

At the front of the transport remove the two screws (item 61, Fig. 6-8) from the push-button escutcheon, and remove the released parts. Remove the two screws (items 65 and 61, Fig. 6-8) from the toggle switch escutcheon, and remove the escutcheon.

Manually support the control box, remove the three screws (item 71, Fig. 6-8) securing the front of the control box, and remove the control box.

Relay actuation and power distribution can be checked with: 1) control box removed, 2) dummy plugs in their receptacles, 3) the two safety switch leads joined and tape-insulated, 4) each solderless connector separately tape-insulated, and 5) cover reinstalled over the tension-adjust resistors. The power cord can then be connected, power applied, and circuits checked.

WARNING

Dangerous voltages are present inside the control box, and across the tension-adjust resistors. Only thoroughly experienced personnel should attempt servicing the energized unit with the bottom cover or the resistor cover removed.

To install the control box, reverse the removal procedures. Check for correct connection of leads to the solenoids, drive motor capac-

itor, and safety switch as shown on Fig. 6-10.

4E.11.4 Power Checks

4E.11.4.1 General

In the following procedures, it is assumed that a sound power cord is correctly installed between the transport and the required power source.

4E.11.4.2 Input Power Check

Set power switch to ON, the power lamp should light. If not, move the takeup tension arm away from the safety switch; if the capstan motor starts, replace the power indicator lamp per paragraph 4E.11.10. If the motor does not start, check the line power, fuses F601 and F602, the power switch, and capacitors C606 and C607 (see Figs. 6-18 and 6-20).

4E.11.4.3 24-Volt Supply Check

Trouble in the 24-volt dc power supply is indicated by the relays all failing to actuate (play, fast forward, rewind, and edit relays). Major electronic components in this supply are transformer T1, diodes CR601 through CR604, capacitor C609, and resistor R602. Remove the bottom cover per paragraph 4E.11.2 and turn power ON.

WARNING

Dangerous voltages are present inside the control box and across the tension-adjust resistors. Only thoroughly experienced personnel should perform this check, which requires an energized circuit.

With a dc voltmeter, check the voltage across capacitor C609 (item 27, Fig. 6-18) for a nominal applied-load power of 24 volts dc, varying with line voltage; the no-load condition is approximately 34 volts dc. If the voltage is absent, or is excessively low, check the components in the 24-volt dc supply. The supply diodes (in the full-wave bridge circuit) and R602 are on a pair of two-lug terminal strips at the right of transformer T1 (just above the rewind motor receptacle) as viewed from the side that

has the tension-adjust resistors. If components are sound, check wiring continuity from the 24-volt power supply to both sides of the ac line supply.

4E.11.4.4 115-Volt Supply Check

Trouble in the 115-volt dc power supply is indicated if the 115-volt solenoids fail to actuate (capstan, main brakes, edit-brakes solenoids).

Major electronic components in this supply are resistor R609 (item 39, Fig. 6-18), capacitor C614 (item 38, Fig. 6-18), and diode bridge rectifier, CR615 through CR618, that is connected to C614 and C609 (item 27). Remove the control box bottom cover per paragraph 4E.11.2 and turn power ON.

WARNING

Dangerous voltages are present inside the control box and across the tension-adjust resistors. Only personnel experienced in working with live circuits should perform this check.

With a dc voltmeter, check the voltage across C614 (item 38, Fig. 6-18) for a 115-volt dc nominal, applied-load, value (the no-load voltage could be up to 150 volts dc). If the voltage is absent, or is excessively low, check the components in the 115-volt dc power supply. If components are sound, check wiring continuity from the 115-volt dc power supply to both sides of the ac line supply.

4E.11.5 Relay Actuation Check (see Figs. 6-20 and 6-21)

Refer to the simplified schematic diagram Fig. 6-21, which shows relay interaction. If one relay fails to actuate, it could result from a malfunction in another relay. Hold the takeup tension arm away from the safety switch, then (with power applied) press the actuating push-button and visually check the relay action. If the relay actuates, check that all contacts are made, then turn power OFF, and clean any contaminated contacts with bond paper or a contact-burnishing tool. Turn power ON, and recheck the relay; if the relay doesn't actuate, proceed as follows:

Step 1: Turn power OFF, and remove the relay. Use an ohmmeter to check across the relay coil (relay pins 13 and 14) for approximately 650 ohms resistance. If the coil is open or shorted, replace the relay. If a replacement is not immediately available, the relays may be interchanged for emergency play/record operations.

Step 2: If the coil seems sound, install the relay and test the relays for the other operation modes (fast forward, play, rewind, and/or edit). If all other functions are normal, turn power OFF and interchange the suspected relay with one known to be good. Recheck relays for all operation modes. If the original circuit operates normally, and trouble is still indicated in the suspected relay, replace the relay.

Step 3a: If the original circuit still does not operate correctly, some other component is preventing relay actuation. Turn power OFF, and remove the control box bottom cover per paragraph 4E.11.2. Remove the relay, and use an ohmmeter to check wiring continuity from the 24-volt dc supply to the pushbutton switch, and then to the relay coil. Also check the diode across the relay coil. Check for the switch closing when the pushbutton is pressed. Check wiring continuity to the negative side of the 24-volt dc supply.

Step 3b: If only the play function was normal in Step 2 (rewind, fast forward, and edit modes inoperative), turn power OFF and remove the bottom cover per paragraph 4E.11.2. Check transistors Q601 and Q602, and other components in that circuit (see Fig. 6-20 and 6-21).

Step 3c: If no mode operates correctly in Step 2, check the 24-volt dc power supply per paragraph 4E.11.4.3.

4E.11.6 Solenoid Actuation Check

4E.11.6.1 General

The solenoids for the main brakes, edit brakes and capstan are actuated by the 115-volt dc power; and the tape lifter solenoid is actuated by the 24-volt dc power. Actuation of all solenoids can be visually checked at the back of the tape transport.

4E.11.6.2 Tape-Lifter Solenoid Check

(a) If the tape is not lifted from head contact during fast forward or rewind modes, but operation is otherwise normal, visually check the tape lifter solenoid actuation. If the solenoid actuates, manually check that the plunger fully bottoms; if it bottoms completely, adjust the tape lifter per paragraph 4E.9.1.

(b) If the tape lifter solenoid does not actuate in either fast forward or rewind, but operation is otherwise normal, check components as follows: 1) Remove the remote-control dummy plug, and check for a sound jumper from pin 12 to pin 8 (do not replace the plug at this time). 2) Disconnect the solderless connectors from the tape lifter solenoid and check the solenoid coil; across the solderless connectors, for approximately 30 ohms resistance. If the coil is open or shorted, replace the solenoid per paragraph 4E.9.2, 3) Check continuity from the "A" lead at the solenoid (see Fig. 6-20) to pin 12 of the remote control receptacle, zero (or low) resistance indicates proper making of the edit switch contacts in the up position. 4) With an ohmmeter, check the diode by checking across the solenoid coil leads into the control box; if the diode is defective, replace it.

(c) Use alligator clips to connect a dc voltmeter to the two leads into the control box ("B" lead, see Fig. 6-20, is positive). Reinstall the dummy plug in its receptacle. Turn power ON, and initiate the fast forward mode; the nominal 24-volt dc power should be indicated on the meter. Repeat the check in the rewind mode. If power is present, the solenoid is probably defective (despite its coil testing correctly); replace the solenoid per paragraph 4E.9.2. If power is absent check wiring continuity to both sides of the 24-volt power supply. If necessary, check overall continuity as follows: 1) remove the dust covers on the fast forward and rewind relays, 2) Check from the control box positive ("B") lead to the positive side of C609 (item 27, Fig. 6-18) while manually actuating relays for the fast forward mode, then the rewind mode; resistance should be zero (or low), 3) Check from the negative ("A") lead to the negative side of C609 without actuating the relays.

(d) If the tape-lifter solenoid actuates in only one fast-winding mode, but both modes otherwise operate normally, it indicates incorrect making of the relay contacts in the failed mode, or poor wiring connections to the relay contacts. On the suspected-defective relay, check the contact set 11-3-7 and the wiring to it.

4E.11.6.3 Capstan Solenoid Check

(a) If the capstan idler doesn't clamp the tape to the capstan when the play pushbutton is pressed, visually check solenoid actuation on the main brake takeup and rewind motors. If the solenoids don't actuate, check their actuation in fast forward rewind modes; if they actuate, check the play relay and its contacts per paragraph 4E.11.5. Replace defective solenoid(s) per paragraph 4E.9.2.

(b) If the brake solenoids fail in all modes, and the capstan solenoid fails in the play mode, initiate the stop/edit mode to check the edit-brake solenoids. If no solenoid actuates, check the 115-volt dc power supply per paragraph 4E.11.4.4, and the 24-volt dc power supply per paragraph 4E.11.3.

(c) If the main brake solenoids actuate when the play pushbutton is pressed in paragraph (a), check the capstan solenoid and its circuit: Disconnect the solderless connectors in the leads to the capstan solenoid. Connect an ohmmeter across the two disconnected leads to check for approximately 1,570 ohms resistance. If the coil is open or shorted, replace the solenoid per paragraph 4E.8.5. Use alligator clips to connect a dc voltmeter to the solenoid leads into the control box ("A" lead is positive, see Fig. 6-20), and press the play pushbutton. The nominal 115-volt power should be indicated on the meter. If power is present, the solenoid is probably defective (despite the coil checking correctly). Replace any defective solenoid per paragraph 4E.9.2.

If power is absent, remove the control box bottom cover per paragraph 4E.11.2. Check wiring continuity from the solenoid to both sides of the 115-volt dc power supply. If necessary, check overall continuity by removing the dust cover from the play relay. Check with an

ohmmeter from the solenoid positive ("A") lead into the control box, to the positive side of capacitor C614 (item 38, Fig. 6-18) while manually actuating the play relay; resistance should be zero (or low). Check from the negative ("B") lead to the negative side of C614 without actuating the relay. Resistance should be zero (or low).

4E.11.6.4 Main Brake Solenoids Check

(a) Actuate main brake solenoids in the play, fast-forward, and rewind modes. In the play mode, actuate the capstan solenoid so that the idler clamps the tape to the capstan. If neither of the brake solenoids or the capstan solenoid actuates in the play mode, proceed per sub-paragraphs (a) and (b) of paragraph 4E.11.6.3.

(b) If the rewind main brake solenoid actuates in the play mode, but the takeup main brake solenoid doesn't, check contacts in the edit relay per paragraph 4E.11.5. Turn power off, then remove the bottom cover of the control box per paragraph 4E.11.2. Disconnect the takeup motor cable from the control box. Use an ohmmeter to check diode CR607 (on the pins at the back of the rewind motor receptacle). Replace the diode if it is defective. Check the solenoid coil resistance, across pins 5 and 6 of the rewind motor plug; it should be approximately 2,300 ohms. If the coil is opened or shorted, replace the main brake solenoid per paragraph 4E.4.7. Reconnect the takeup motor cable to the control box, and disconnect the solderless connectors from the main brake solenoid. Use alligator clips to connect a dc voltmeter to the solenoid leads from the motor plug (the pin 5 lead is positive). Turn power ON, and initiate the play mode; the nominal 115-volt dc power should be present across those leads. If voltage is present, the main brake solenoid is probably defective (despite its coil testing correctly); replace the solenoid per paragraph 4E.4.7. If voltage is absent, check wiring continuity from the leads to both sides of the 115-volt power supply. If necessary, check overall continuity by removing the dust covers from the play, rewind, and fast forward relays. Check from the negative lead (pin 6 of the plug) to the negative side of C614 (item 38, Fig. 6-18), and manually actuate the play relay, then the rewind relay, and then the fast forward relay; resistance should be zero (or low) when each relay is actuated. Check

from the positive lead to the positive side of C614 without actuating any relay; resistance should be zero (or low).

(c) If the takeup main brake solenoid actuates in the play mode, but the rewind main brake solenoid doesn't, turn power OFF, then disconnect the rewind motor cable from the control box. Check across pins 5 and 6 of the rewind motor cable plug, for approximately 2,300 ohms resistance. If the coil is open or shorted, replace the solenoid per paragraph 4E.4.7. Remove the control box bottom cover and use an ohmmeter to check diode CR610 (soldered across pins 5 and 6 on the back of the rewind motor receptacle). Reconnect the rewind motor cable to the control box, and disconnect the solderless connectors in the leads to the solenoid. Use alligator clips to connect a dc voltmeter across the two solenoid leads to the connector. Turn power ON, and initiate the play mode. The nominal 115 volts dc power should be present across those leads. If the voltage is present, the solenoid is probably defective (despite its coil checking correctly) replace the solenoid per paragraph 4E.4.7. If the voltage is not present, check wiring continuity from the solenoid leads to both sides of the 115-volt dc power supply. If necessary, check overall continuity by removing the dust covers from the play, fast forward, and rewind relays. Connect the ohmmeter from the negative lead (pin 6 of the plug) to the negative side of C614 (item 38, Fig. 6-18). Manually actuate relays for the play mode, then the fast-forward mode, and then the rewind mode. Resistance should be zero (or nearly zero) when each relay is actuated. Check from the positive pin 5 of the plug lead to the positive side of C614, without actuating any relay. Resistance should be zero (or nearly zero).

4E.11.6.5 Edit-Brake Solenoid Check

(a) If both edit-brake solenoids (on the takeup and rewind motors) fail to actuate in the stop/edit mode, check fast-forward and rewind actuation of the main brake solenoids, and play actuation of the main brake solenoids and capstan solenoid. If none of these solenoids actuate, check the 115-volt dc power supply per paragraph 4E.11.4.4. If all other solenoids actuate normally, check the edit relay action and contacts per paragraph 4E.11.5; replace the relay if necessary. If the relay action is

normal, turn power OFF, then remove the control box bottom cover per paragraph 4E.11.2, and disconnect the rewind and takeup motor cables from the control box. Use an ohmmeter to check diode CR611 (connected across pins 7 and 8 on the back of the rewind motor receptacle); replace the diode if it is defective.

(b) The only other likely cause for solenoid failure to actuate, is defective wiring to the 115-volt dc power supply. Disconnect the solderless connectors to one edit-brake solenoid, and use alligator clips to connect a dc voltmeter across the leads to the plug (the pin 7 lead is positive). Turn power ON and press the edit pushbutton. The nominal 115-volt dc power should be present across the leads; if not, remove the dust cover from the edit relay. With an ohmmeter, check from the positive lead to the positive side of C614 (item 38, Fig. 6-18) while manually actuating the edit relay; resistance should be zero (or near zero). Check from the negative lead to the negative side of C614 without actuating the relay, resistance should be zero (or near zero).

(c) If only one of the solenoids actuates in the stop/edit mode, the non-actuating solenoid is probably defective, because they are tied together across the rewind and takeup receptacles. Disconnect the cable from the control box. Check across pins 7 and 8 on the motor cable plug for approximately 2,300 ohms resistance. If the coil is open or shorted, replace the solenoid per paragraph 4E.4.7. Check voltage and resistance of the non-actuating relay per subparagraph (b).

4E.11.7 Drive Motor Check

(a) If the power lamp lights when power is applied, but the capstan motor does not start in rotation when tape is threaded, manually move the takeup tension arm away from the safety switch. Then press the edit pushbutton to initiate the stop/edit mode, if turntable braking force is reduced so the reels can easily be turned, the safety switch is operating correctly. If not, 1) adjust the safety switch actuation per paragraph 4E.7.2, and/or 2) adjust the spring force of the takeup arm per paragraph 4E.7.1, and/or 3) replace the safety switch per paragraph 4E.10.

(b) Disconnect the drive motor cable from the control box. Set the speed switch to HIGH, turn power ON, and check voltage with an ac vtm across receptacle pins 4 and 5, and then pins 3 and 5. Full line power should be present at both positions; this indicates that the speed switch is closed and the motor capacitor is not open. When the speed switch is set at LOW, the check is made across receptacle pins 1 and 5. If voltage is available at pins 4 and 5 (or 1 and 5) and not across 3 and 5 (or 2 and 5) the motor capacitor is probably open; replace it per paragraph 4E.5.4. Even though voltages are correct, check that the motor capacitor is not shorted; also check the solderless disconnects at the motor capacitor (see Fig. 6-10).

(c) If the motor capacitor operates correctly, or if power is not available across either pair of receptacle pins, turn power OFF. Remove the bottom cover, and with an ohmmeter, check each position of the speed switch (view A-A, Fig. 6-18) for contact make-break action. If any capacitor C602 through C605 is shorted, voltage will be present at receptacle pins for the circuit opposite to the speed selected, and the motor would probably always run at the slow speed (regardless of the speed selected).

(d) If voltages are present at both receptacle pin pairs, and the motor capacitor is sound, the drive motor is probably defective; check and replace per paragraph 4E.5.3. Motor cabling connections are shown on Fig. 6-16.

4E.11.8 Takeup Motor Check

If the power lamp doesn't light when power is ON, check input power per paragraph 4E.11.4.2. If the capstan motor doesn't operate when tape is threaded, check it per paragraph 4E.11.7.

(a) Press the play pushbutton, the capstan idler should clamp the tape against the rotating capstan, and the takeup motor should start to wind the tape. If the capstan idler operates normally, but the takeup motor fails to

start, check deactuation of the edit relay per paragraph 4E.11.5; if it fails to deactuate, remove the bottom cover and, with an ohmmeter, check the opening and closing of the edit switch. If the edit relay deactuates, check the safety switch actuation per paragraph 4E.7.2 (even when the safety switch is correctly adjusted, some trouble could remain in the takeup motor circuit).

(b) If the capstan idler doesn't clamp the tape to the capstan, check that the dummy plug (or a remote control unit) is plugged into the control box remote-control receptacle. Check that the jumpers in the dummy plug are sound. Check that the rewind motor applies holdback tension on the tape; if not, check the play relay actuation and contacts per paragraph 4E.11.5.

(c) If the capstan idler clamps the tape, and the takeup motor starts, but a loose tape loop allows the takeup tension arm to actuate the safety switch (stopping all operations), check the takeup and rewind tape tensions per paragraph 4C.2.3. Then check the spring force on the takeup tension arm per paragraph 4E.7.1.

(d) If the capstan correctly clamps the tape, but the takeup motor fails to start, there is probably a malfunction in the motor circuit. Initiate the fast-forward mode; if the motor operates normally, the motor and capacitor are sound and the brake solenoid energizes correctly. Check the fast-forward relay deactuation and contacts per paragraph 4E.11.5. Check contacts and continuity of the takeup tension-adjust resistor R605 (at the back of the control box). Malfunction of the play and edit relays can cause other malfunctions covered in the preceding paragraphs of this section.

(e) If the motor fails to operate in either play or fast forward modes, check the takeup reel switch; if it is set at the small hub position change it to the large hub position. If this eliminates the trouble, check the small-hub tension-adjust resistor R606 (on the back of the control box) per paragraph 4C.2.3. If the trouble isn't eliminated, or if the switch was originally in the large hub position, visually check actuation of the main brake solenoid. If it fails to actuate, check it per paragraph 4E.11.6.4. If it actuates, disconnect the takeup motor cable from the control box. Remove any tape threaded on the equip-

ment, and hold the takeup tension arm away from the safety switch. Press the fast forward push-button, and use an ac vtvm to check voltage across motor receptacle pins 1 and 2, full line power should be present; if not, check wiring continuity to both sides of the ac line. Remove the dust caps from the play and fast-forward relays, and check the high side of the line. Manually actuate the fast forward relay; resistance should be zero, or near zero (reel switch in large-hub position). Release the fast forward relay, and manually actuate the play relay. The resistance should be that set at takeup tension-adjust resistor R605.

(f) If motor voltage is present, check the motor capacitor connections at the solderless connectors (see Fig. 6-12), then check the capacitor. If it is open or shorted, replace it per paragraph 4E.4.9. If voltage is present and the capacitor is sound, the takeup motor is probably defective. Check the motor per paragraphs 4E.4.2 and 4E.4.5. Motor cabling connections are shown on Fig. 6-12.

4E.11.9 Rewind Motor Check

If the power lamp doesn't light when power is ON, check power per paragraph 4E.11.4.2. If the capstan drive motor doesn't operate when tape is threaded, check the motor per 4E.11.7. If the takeup motor doesn't operate, check it per paragraph 4E.11.8.

(a) If the rewind mode fails to function, remove the tape from the transport. Hold the takeup tension arm away from the safety switch and initiate the play mode. The rewind turntable should rotate clockwise, the takeup turntable should rotate counterclockwise, and the capstan idler should contact the capstan. If operation is correct, press the rewind pushbutton. If this doesn't stop the play mode (capstan idler moves away from capstan) check rewind relay actuation and contacts per paragraph 4E.11.4. If the play mode drops out, the rewind relay is actuating correctly.

(b) If only the takeup motor operates, check the supply reel switch. If it is in the small-hub position, move it to the large-hub position. If the rewind motor now operates, check small-hub tension-adjust resistor R608 per paragraph

4C.2.3. Also visually check actuation of the main brake solenoid; if it fails to actuate, check it per paragraph 4E.11.6.4.

(c) If changing the reel switch setting has no effect, and the main brake solenoid actuates, disconnect the rewind motor cable from the transport control box. Hold the takeup tension arm away from the safety switch, and press the rewind push-button. With an ac vtm, check voltage across the rewind motor receptacle pins 1 and 2 on the control box; full line-power voltage should be present (reel size switch in large-hub position). If voltage is absent, or is excessively low, check wiring continuity to the ac line. Manually actuate the rewind relay; resistance should be zero (or near zero). Release the rewind relay, and manually actuate the play relay; resistance should be that set across holdback tension-adjust resistor R604. If continuity is correct, recheck actuation and contacts on the play and rewind relays per paragraph 4E.11.5.

(d) If required voltage is present, check the rewind motor capacitor connections at the solderless connectors (see Fig. 6-13), then check the capacitor. If the capacitor is open or shorted, replace it per paragraph 4E.4.9. If voltage is present and the capacitor is sound, the rewind motor is probably defective. Check and replace the motor as necessary per paragraphs 4E.4.2 and 4E.4.5. Motor cabling connections are shown on Fig. 6-13.

4E.11.10 Power Lamp Replacement

To replace the power lamp remove the two screws (item 61, Fig. 6-8) securing the escutcheon over the pushbuttons and remove the released parts. Remove the two screws (items 61 and 65, Fig. 6-8) securing the escutcheon over the toggle switches, and remove the released parts. Remove the lamp from the socket with a lamp extracting tool; if the tool is not available, the control box must be removed from the transport per paragraph 4E.11.3 for lamp removal.

4E.11.11 Switch Replacement

Remove the control box from the transport per paragraph 4E.11.3. When new push-button switches are installed, set the switch face to 19/32 ($\pm 1/32$) inch above the chassis. Set

toggle switch handles 1-5/16 ($\pm 1/32$) inch above the chassis.

4E.11.12 Record Circuit Check

Initiate the record mode, by starting tape in the play mode and actuating the record circuits. Two switching transistors, Q601 and Q602, lock out the edit, fast-forward, and rewind modes while the equipment is recording. Q601 is therefore in the negative return lead from the edit, fast-forward, and rewind relays. When the record mode is initiated, transistor Q602 is turned on, which turns Q601 off.

If it is possible to start the edit, fast-forward, or rewind modes from the record mode, transistor Q602 (item 24, Fig. 6-18) may be open or Q601 (item 23, Fig. 6-18) may be shorted. If it is impossible to start the modes, transistor Q602 may be shorted or Q601 may be open. No malfunction of either transistor will prevent initiating of the record mode.

Section 4

MAINTENANCE**Part F. Electronic Corrective Maintenance****4F.1 GENERAL**

Use standard audio troubleshooting techniques to isolate faults to a certain stage or component. The dc, signal, and bias voltages are given at many points on the schematic diagram, as an aid in locating malfunctions. Schematic diagrams for the recorder/reproducer circuits are in Figs. 6-22 and 6-24; and for the reproducer, Figs. 6-23 and 6-25. The diagram for power distribution and fusing is in Fig. 6-19.

NOTE

Overall performance checks for the electronic system are described in paragraph 4B.4. Electronic alignment is given in paragraphs 4C.3 and 4C.4.

4F.2 EXTENDER BOARDS USE

Corrective maintenance procedures are greatly simplified by using the optional extender boards. The extender board, when installed between a circuit board and its receptacle, moves the circuit board outside the chassis so all

components are accessible for testing/adjustment (the extended circuit boards must be mechanically supported).

Extender board catalog numbers are as follows: reproduce, 4020151; record, 4020152; bias amplifier, 4020153; and power supply, 4020154.

4F.3 INPUT POWER AND INDICATORS CHECK**4F.3.1 Recorder/Reproducer**

When power is ON, the transport POWER lamp, and the record/reproduce unit VU meter lamps should light. If the POWER lamp doesn't light, check it per paragraph 4E.11.4 and refer to the power distribution and fusing diagram, Fig. 6-19.

(a) If the POWER lamp lights, but the VU meter lamps don't, set the RECORD SELECTOR switch to READY. If the READY lamp lights, one of the VU meter lamps is probably defective (these lamps are connected in series).

Replace any defective meter lamps per paragraph 4F.9.1.2.

(b) If the READY lamp doesn't light, check fuse 4F1 on the back panel of the record/reproduce unit. If the fuse is sound, check fuse F701 on the transport power supply box. If both fuses are sound, use a dc voltmeter to check any receptacle J701 through J704 (on the power supply box) across pins 9 (positive) and 5. The 39-volt-dc power should be present across those pins; if not, check for the voltage on the power supply board (see schematic diagram, Fig. 6-22). If the voltage is present, check the interconnecting cable, and internal wiring, then correct any defects.

(c) If the POWER and VU meter lamps light, and the READY lamp doesn't, with the SELECTOR switch at READY, replace the lamp per paragraph 4F.9.1.1.

(d) If the VU meter and the READY lamps light, and the RECORD lamp doesn't, when the record mode is initiated, set OUTPUT SELECTOR to BIAS (in the record mode). If the VU meter indicates normal bias, replace the lamp per paragraph 4F.9.9.1.

(e) If bias isn't indicated on the VU meter, check the relay per paragraph 4F.4.

4F.3.2 Reproducer (only)

(a) If it is suspected that operating power is not available, use a dc voltmeter to check across pins 9 (positive) and 5 on any receptacle J701 through J704 (on the transport power supply box). If the +39-volt dc power isn't present, check fuse F701 on the power supply box.

(b) If voltage is absent and the fuse is sound, check the power supply circuit board (see schematic diagram Fig. 6-23).

(c) If voltage is present, install the reproduce board on an extender card and check for the +39-volt power at any convenient point (see schematic diagram, Fig. 6-25). If voltage is absent, check the interconnecting power cable, and internal wiring; correct any defects.

4F.4 RECORD RELAY CHECK

The record relay, the only one used in a record/reproduce unit, is identical to the four relays on the tape transport.

(a) If the record relay is suspected to be inoperative, remove the dust cover from the relay. Hold the takeup tension arm away from the safety switch, set the record selector to READY, and initiate the play mode. Press and release the record pushbutton; if the relay actuates and holds in the energized position, check contact closure. If contacts are dirty, rub them clean with bond paper or a contact-burnishing tool.

(b) If the relay does not actuate and hold, remove it from its receptacle. Check the dc resistance of the coil across relay terminals 13 and 14; resistance should be approximately 650 ohms. If the coil is open or shorted, replace it. For emergency recording, substitute any other sound relay from the tape transport (refer to paragraph 4E.2).

(c) If the relay coil action is correct, remove the interconnecting power cable at J11 (on the record/reproduce unit). Initiate the play mode, and use a dc voltmeter to check across cable plug pins 10 (positive) and 8; the 24-volt dc holding power should be present. Connect the dc voltmeter across cable plug pins 4 (positive) and 8. Initiate the play mode, then press and hold the record pushbutton. The 24-volt power should be present across the pins. If power is absent at either checkpoint, check wiring continuity to the transport 24-volt dc power supply.

(d) If the holding and energizing voltages are both present, remove the relay from its receptacle (leave the J11 receptacle open). Use an ohmmeter to check the diode across pin 4 of J11 to relay receptacle pin 14. Check the other diode across relay receptacle pins 14 and 13. Check resistor 4R77 across relay receptacle pins 14 and 12. Check actuation of the RECORD SELECTOR switch, by connecting the ohmmeter from pin 8 of J11 to relay receptacle pin 13 and switching the record selector from SAFE (open) to READY (closed).

(e) If voltage was present and no faulty component is found, the relay is probably defective (despite its coil testing correctly); replace the relay.

4F.5 POWER SUPPLY CHECK

The power supply voltage-regulator adjustment is given in paragraph 4C.3.5.

(a) The power supply 39 (-1/2,+1) volts dc power should be present at three pins of any of the receptacles J701 through J704 (on the power supply box). Initiate the reproduce mode, then use a dc voltmeter to check between pins 9 (positive) and 5 of one open receptacle. Select high speed (in the reproduce mode) then use the dc voltmeter to check across pins 7 (positive) and 5 for the high-speed equalization switching voltage. Select low speed, then check across pins 6 (positive) and 5 for the low-speed equalization switching voltage. The regulated dc voltage should be present at all three check points. If power is present across pins 9 and 5, and not present at either one of the other points, check the SPEED switch, or continuity of the cabling and internal wiring; correct any defects.

(b) If no voltage is present, check fuse F701 on the power supply box. If the fuse is sound, open the power supply box and mount the power supply board on the extender board. If voltage is present, but is excessively high, proceed to (f).

WARNING

Dangerous voltage is present across the fuse post and across the transformer leads, so use special care when making the following checks.

(c) With all record/reproduce units connected, set all channels to the record mode. Use the dc voltmeter to check across CR706, CR705, and R707; with the voltmeter positive lead at the CR706 innermost end, and the negative lead to the R707 outermost end. The voltage present depends on applied load and the power and component tolerances; therefore, these values are only nominal: for a single channel, 72 volts; two channels, 66 volts; three channels, 60 volts; and

four channels, 54 volts.

(d) If voltage is absent or is excessively low, turn power OFF and use an ohmmeter to check CR706, CR705, and R707 on the power supply board. If component values are correct, remove the transport power supply box per paragraph 4E.3. On the box mounting side, check capacitor C707, resistor R706, and the diodes CR701 through CR704 (which make up the full-wave bridge rectifier). If they are sound, remove the heat sink panel with power transistor Q705. Connect the box to the transport and apply power. See the above WARNING, then use an ac vtm to check voltages at the primary (white/black) lead and secondary (red/red) leads of the power transformer (T702).

(e) If the voltage seems correct in (c), check transistors Q706 (shorted), Q704 (open), and Q703 (open). Then check all other components in their immediate circuits (all are on power supply board). Also check capacitor C706 (shorted) and power transistor Q705 (open) on the heat sink.

(f) If voltage is present in (a), but is excessively high, adjust the regulator per paragraph 4C.3.5. If the regulator won't adjust within tolerance, remove the power supply board from the box. Use the ac vtm to check transistors Q706 (open), Q704 (shorted), and Q703 (shorted) and all components in their immediate circuits. Check power transistor Q705 (shorted), on the box mounting side.

4F.6 BIAS CHECK

If trouble is found in the recorder/reproducer bias or erase circuit, the malfunction could be in the master bias oscillator (on the power supply's circuit board) or the bias amplifier module. On multi-channel equipment with trouble indicated on all channels, the master bias oscillator is probably defective; if the trouble is on only one channel, that channel's bias amplifier is probably defective.

Isolate trouble to any one circuit by moving its bias amplifier out on the extender board, and measuring the bias input with an ac vtm connected across resistors 3R90 and 3R91; bias voltage should be as shown on the schematic diagram,

Fig. 6-24. If this voltage is correct, the trouble is probably in the bias amplifier module; if it is incorrect, the master bias oscillator is probably defective.

WARNING

Dangerous voltages are present across the fuse post and at the transformer leads inside the power supply box, so use special care when checking the master bias oscillator.

Bias and dc voltages are shown at key points on the schematic diagram, Fig. 6-24. Initiate the record mode and check these voltages to quickly isolate trouble to a particular stage or component. The dc voltage is applied to the bias amplifier only in the record mode. Check the simple push-pull master bias oscillator with the power supply circuit board on an extender board.

4F.7 RECORD/REPRODUCE CHECK

4F.7.1 General

On a recorder/reproducer, if a tape doesn't play back correctly on the machine which recorded it, the record and/or reproduce circuit could be defective. Check the circuit functions by playing back a tape known to have been recorded correctly. If the tape reproduces normally, the record circuit is defective; if it doesn't, the reproduce circuit is defective.

When trouble is evidenced, check power per paragraph 4F.3 and check both equalization switching voltages per paragraph 4F.5. Refer to the schematic diagram, Fig. 6-24.

4F.7.2 Record Check

If trouble is indicated in the record circuit, check that the record head and signal input are correctly connected and that the dummy plug (or accessory) is in the input accessory socket (on the record/reproduce unit back panel). To check the bias voltage, initiate the record mode and set the output selector to BIAS; if the bias voltage is not normal, check it per paragraph 4F.6.

Check the record relay per paragraph 4F.4.

4F.7.2.1 Servicing Hints

Servicing hints, which should prove helpful, follow:

(a) Signal voltages and dc voltages are shown in the schematic diagram, Fig. 6-24. Use extender cards and check the voltages to quickly isolate the fault to a specific stage or component.

(b) Initiate the mode and set the output selector to INPUT. Check that the VU meter indicates a normal signal input. If not, the trouble is probably in stage 2Q9 or the plug-in equalizer board. If the VU meter indication is normal, the trouble is in stages 2Q10 through 2Q15.

(c) Transistor 2Q10 conducts only when the low tape speed is selected; 2Q11 conducts only when the high tape speed is selected.

(d) If the output selector is at INPUT, and the VU meter indication seems normal for the record line input, the fault is in stages 1Q1 through 1Q4. If the indication is not normal, stages 1Q5 through 1Q8 are defective.

4F.7.3 Reproduce Check

If trouble is evidenced or suspected in the reproduce circuit, check that the reproduce head and the output line are correctly connected. Connect head set to the phones jack (on the unit front); if the signal there is normal, the output transformer or output line is defective.

4F.8 8 REPRODUCER CHECK

Check signal and dc voltages to those shown on the schematic diagram, Fig. 6-25, using the extender board for the reproduce circuit in record/reproduce units.

4F.9 PARTS REPLACEMENT

4F.9.1 Indicator Lamps

The Ready/Record lamps are mounted in a spring clip. To replace either lamp, remove the top cover from the record/reproduce unit, pull the wired sockets from the lamps with long nose pliers, then press the two clip extrusions together and remove the clip--being careful not to let the pliers slip. Remove the lamp (now free) through the front of the assembly. Install a lamp in reverse to removal procedures, then press the clip against the panel to secure the lamp.

To remove a VU meter lamp, remove the record/reproduce unit bottom cover. Pull the wired sockets from the lamp then pull the lamp out of the meter housing. Install lamps in the reverse order to removal procedures.

4F.9.2 Circuit Board Components

Required removal tools are: 1) 50-watt (maximum) pencil-type soldering iron, 2) noncorrosive soldering flux with rosin-alcohol base, and 3) piece of small-diameter shielding braid; use a plunger-type solder remover if available (instead of the soldering flux and shielding braid).

To remove a component, dip the shielding braid in the soldering flux. Heat the solder joint with the soldering pencil (never use a soldering gun or high-wattage iron), and dip the braid into the molten solder (the solder flows into the braid). Do not overheat soldering joints during this procedure, and especially avoid heating joints that are not to be unsoldered. When solder has been removed from all component leads, the part should then be removed without exerting excessive force.

To install the replacement part, bend the leads to fit in the mounting holes. Insert the leads through the holes, then bend them flat against the foil path. Use the soldering pencil, and low-melting-point rosin-core solder to solder the joints. Do not overheat the junction or nearby junctions. Remove excess rosin from the joint with a clean lint-free cloth moistened with alcohol.

After replacing a diode or transistor, allow the board to cool approximately five minutes before reinstalling it.

CAUTION

Residual soldering heat could cause thermal runaway if power is applied to a semiconductor device during the five-minute cooling period.

4F.9.3 Other Components

All other components are accessible when the top or bottom cover is removed. Component location on the schematic diagram, Fig. 6-24, is indicated by a number before the identification letter. A table on the diagram gives the prefixes used, and the component locations. The assembly drawings, Fig. 6-26 through 6-29 can help in finding parts.

4F.10 RESPONSE CURVE CHECK

Response curves for record and reproduce are shown in Figs. 6-32 and 6-33. To check these curves proceed as follows:

Disconnect the head cables, input cable, and output cable from the receptacles. Connect the signal generator and the vtvm as shown in Fig. 4F-1 for record; or Fig. 4F-2 for reproduce. Set the generator for a 0.78-volt (0-dBm) output.

To check the record amplifier curve, remove the bias amplifier plug-in circuit board. Hold the takeup tension arm away from the safety switch, and initiate the record mode.

To check the reproduce amplifier curve, turn power ON, then operate the generator in small uniform steps over the specified frequency range for the set tape speed. Adjust the equalization controls to set the amplifiers to the curve.

Reinstall the bias amplifier and reconnect the cables.

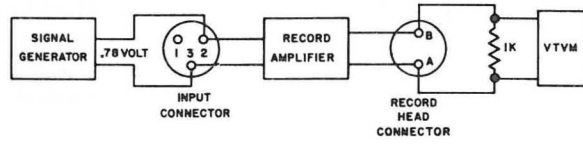

Fig. 4F-1. Record Response Check Setup

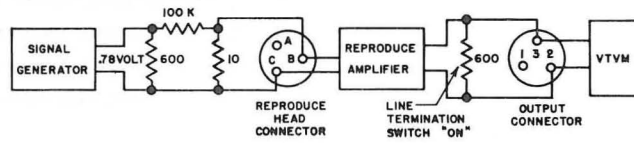

Fig. 4F-2. Reproduce Response Check Setup

SECTION V

THEORY OF OPERATION

Section 5

THEORY OF OPERATION

5.1 TAPE TRANSPORT

5.1.1 General

Tape motion is controlled by the tape transport mechanism for all operation modes. The transport consists basically of a tape supply system, a tape drive system, a tape takeup system, and a control system. These systems provide smooth and positive tape motion across the magnetic heads, and maintain correct tape tension.

A schematic diagram of the tape transport is provided in Fig. 6-20, and a simplified schematic in Fig. 6-21. The front and back of the transport are shown in Fig. 5-1. The power-distribution and fusing diagram is in Fig. 6-19.

5.1.2 Tape Supply and Takeup Systems

A separate motor drives each supply and takeup assembly. These two motors are connected so that if power is applied with no tape threaded, the turntables will rotate in opposite directions--the supply turntable clockwise and the takeup turntable counterclockwise.

In the play or record modes of operation, the capstan controls tape speed; it pulls tape from the supply reel (whose opposing torque helps to maintain tape tension) and delivers it to the takeup reel, which also helps maintain correct tape tension. The motor torque, and therefore tape tension, is adjustable at resistors R604 (supply) and R605 (takeup).

During fast-forward or rewind operation, the capstan is disengaged from the tape. The power of one of the motors is reduced by switching an adjustable resistor (R607) into series/circuit with it; the other motor continues to operate at full power. The turntable under full power pulls the tape against the torque of the other turntable, which provides required tape tension.

When reels with small hubs are used, additional resistors are operator-switched into the circuit to lower the tape tension to the correct level. The reel switches for large hub operation, short the adjustable resistors (R608, supply, and R606, takeup).

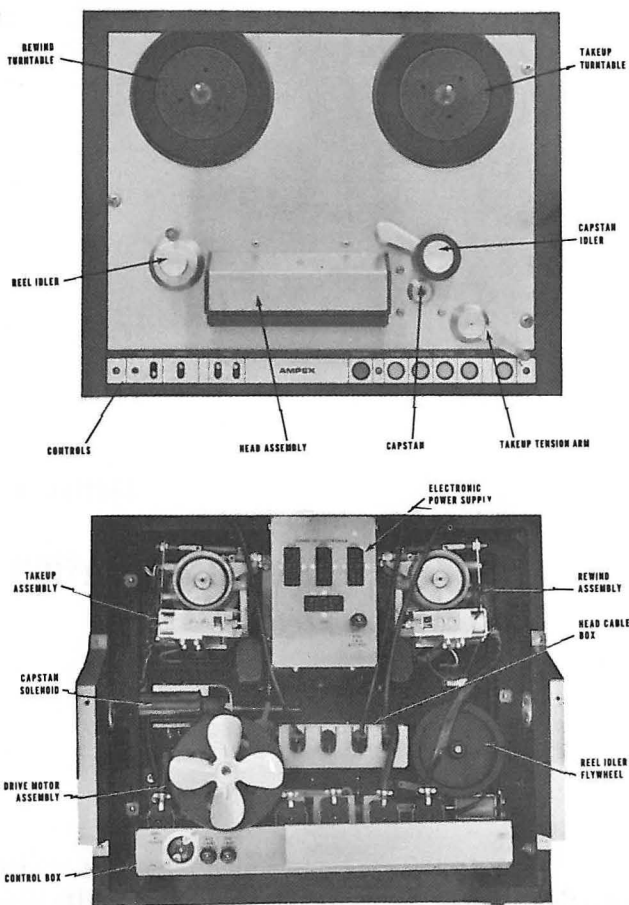

Fig. 5-1. Tape Transport

A pair of solenoid-controlled brakes is mounted on each of the two torque motors. The main-brake solenoid on each motor is energized (brakes released) whenever tape is placed in motion in any mode. The edit-brake solenoid on each motor is energized only in the stop-edit mode, to reduce braking force at each turntable. The edit brake always contacts the drum, but full braking force is applied only when it is energized.

To prevent the formation of tape loops when tape motion is stopped, the reverse-rotation main-brake force is adjusted to about triple the forward-direction force.

5.1.3 Tape Drive System

The capstan drive force is from hysteresis-synchronous motor. The capstan (tape drivewheel) is the motor shaft end that is precision-machined and hardened; the other end of the motor shaft mounts a flywheel and fan. A solenoid-controlled capstan idler clamps the tape to the

capstan to provide the driving friction against the tape.

The drive motor has a separate field winding for each of the two tape speeds. A speed toggle switch selects the desired tape speed, and also automatically switches in the correct solid-state equalization circuit for each speed. The drive motor operates continuously when power is ON and a tape is correctly threaded.

When the recorder/reproducer is in the play (or record) mode, solenoid (K610) energizes and moves the capstan idler to clamp the tape against the rotating capstan. The main brake solenoids (K605 and K607) energize to release the brakes. The capstan then drives the tape across the head assembly at the selected speed.

5.1.4 Reel Idler

A reel idler assembly, on the transport left side, below the supply turntable, minimizes any tape motion transients caused by the supply assembly. The reel idler arm minimizes initial strain when tape motion starts (to avoid stretching or breaking the tape) and prevents formation of a tape loop between the supply reel and the heads. The idler pulley flywheel serves to dampen transients in tape speed that could result from torque motor cogging and uneven tape wrap on the supply reel.

To set the tape guide on the idler arm for either 1/4-inch or 1/2-inch wide tape, it is lifted and rotated to present the correct face to the tape.

5.1.5 Takeup Tension Arm

The tape takeup tension arm has two functions, it maintains a small tape loop (to prevent tape breaking or stretching during start and stop) and it actuates the safety switch (S603), to stop operation if a large tape loop forms, or if the tape breaks. The tension arm also stops the transport when either reel runs out of tape.

The guide for the tape is similar to that on the reel idler (refer to paragraph 5.1.4). A tape hook holds tape on the guide during threading and when the tape becomes slack.

5.1.6 Tape Lifter

A solenoid-operated tape lifter assembly raises the tape from contact with the heads during fast-forward or rewind operation. When either mode starts, the solenoid K609 energizes and moves the tape lifter mechanism. The tape lifter is defeated as long as the edit pushbutton is pressed. The tape lifter may be manually defeated by opening the head gate and pushing the right-hand tape lifter arm to the retracted position.

In the fast forward or rewind mode the tape-lifting arms do not retract instantly when the stop button is pressed. An electronic delay is provided so that the tape stops completely before contacting the head, which avoids the high-peak signal that results from the moving recorded tape contacting the heads.

The delay circuit for the record-stop function involves terminals E1 through E6 on the small circuit board in the control box.

The play relay circuit's negative side is connected through SCR Q603 to the power supply. During the play mode, pressing the STOP button causes Q603 to stop conducting and switch the play relay off. During the record mode, the record-relay holding current passes through Q602 (base to emitter) causing it to conduct the power supply voltage through E5 and CR620 to charge capacitor C619. When the STOP button is pressed, the capacitor discharges through CR621 into the play relay coil to hold the relay on for 1/4 second after Q603 de-energizes. Therefore, the time delay occurs only when the STOP button is pressed during the record mode.

The sole function of capacitor C620 is to maintain a charge to turn on Q603 when the play relay is actuated.

The sole function of diode CR619 is to block negative flowing current from interfering with delay of the relay.

In addition, when the tape is stopped in the record mode, the control logic assumes that the tape "coasts" about 250 milliseconds before stopping. This allows the tape-biasing rf current to completely decay before tape motion ends, which avoids the loud noise that results from the tape

stopping while bias current is still present in the record head.

The delay circuit for the tape-return-to-head function involves terminals E7 through E13 and Q606 on the small circuit board in the control box.

When the transport isn't in the rewind mode, no voltage appears at E11 so the two-transistor flip-flop circuit has Q604 non-conducting and Q605 saturated. Power appears at E11 when the FAST FWD or REWIND button is pressed, which reverses the transistor states to turn on power transistor Q606 resulting in tape lifter actuation, to lift the tape from the heads.

When either fast wind mode is stopped, the tape lifter is held from the play position by the discharging of capacitor C621 through the adjustable potentiometer R619. The time delay for returning the tape to head-contact can therefore be set by adjusting R619.

5.1.7 Control Circuit

5.1.7.1 Play Mode

When tape is correctly threaded and power is applied, the capstan rotates at the speed selected at the speed switch. Pressing the PLAY pushbutton then results in the following circuit action:

Play relay K602, in the 24-volt dc circuit, is energized. Contact set 1-9-5 of that relay completes a holding circuit across the play pushbutton. Contact set 2-10-6 applies ac power (through the tension-adjust resistors) to the takeup and rewind supply motors. Contact set 3-11-7 completes the 115-volt dc energizing circuit to the capstan idler solenoid. Contact set 4-12-8 connects 115-volt dc to energize the supply and takeup main brake solenoids. Thus the brakes release, the turntable motors operate, and the tape (pressed against the rotating capstan) is driven at the selected speed.

5.1.7.2 Fast-Forward Mode

The negative return for fast-forward, rewind, and edit relays is through transistor Q601, which must conduct to allow those modes to actuate

(refer to record mode, paragraph 5.1.7.5).

With power on and tape threaded, pressing the FAST FWD pushbutton energizes fast-forward relay K604. Contact set 1-9-5 of that relay opens the 24-volt dc circuit to the play circuit, and closes a holding circuit across the fast-forward switch. Contact set 2-10-6 connects full ac power to the takeup motor (reel switch in large hub position) and reduced ac power (through resistor R607) to the rewind motor. Contact set 3-11-7 opens the 24-vdc circuit to the rewind relay, and closes the 24-vdc circuit to tape-lifter solenoid K609, through edit switch S611. Contact set 4-12-8 conducts the 115 vdc to energize main-brake solenoids K605 and K607. The takeup motor therefore operates at full torque, the rewind motor at reduced torque; tape is lifted from head contact, the brakes are released, and the tape winds from the rewind to the takeup reel.

5.1.7.3 Rewind Mode

The negative return for the rewind, fast-forward, and edit relays is through transistor Q601, which must conduct to allow those modes to actuate (refer to record mode, paragraph 5.1.7.5).

With power on and tape threaded, pushing the REWIND pushbutton energizes rewind relay K601. Contact set 1-9-5 completes a holding circuit across the rewind switch. Contact set 2-10-6 connects full ac power to the rewind motor (reel switch in large hub position), and connects reduced ac power (through resistor R607) to the takeup motor. Contact set 3-11-7 breaks the 24-vdc circuit to the play and fast-forward circuit and connects 24-vdc to tape-lifter solenoid K609. Contact set 4-12-8 connects 115 vdc to energize main-brake solenoids K605 and K607. Thus, the rewind motor operates at full torque, the takeup motor operates at reduced torque, the brakes are released, tape is lifted from contact with the heads, and tape rewinds from the takeup reel to the supply reel.

Tape lifter action in the rewind mode, as in the fast-forward mode, can be defeated by pressing the EDIT pushbutton.

5.1.7.4 Edit Modes

The negative return for the edit, rewind, and fast-forward relays is through transistor Q601, which must conduct to allow those modes to actuate (refer to record mode, paragraph 5.1.7.5).

When the edit relay is energized in either the stop/edit or the play/edit mode, contact set 1-9-5 completes a holding circuit across the edit switch. Contact set 2-10-6 opens the 115 vdc circuit to the takeup main brake solenoid and closes the 115 vdc circuit to the takeup and supply edit brake solenoids. Contact set 3-11-7 opens the 24 vdc circuit to the record switch, locking out the record mode. Contact set 4-12-8 opens the ac circuit to the takeup motor and closes a shorting circuit across the safety switch to bypass the switch.

In the stop/edit mode, therefore, the safety switch is shorted and the low braking force (supplied by the edit brake solenoids) makes it easy to manually turn the reels. In the play/edit mode, the safety switch is shorted, the record mode is locked out, ac power is removed from the takeup motor, the supply brake is fully released (by the supply main brake solenoid), and the takeup turntable is held by the takeup brake solenoid action; therefore the takeup turntable will not rotate, and tape will spill off the right side of the transport.

The edit relay is not energized in the fast-winding/edit mode. This mode simply defeats the tape lifting mechanism while the edit pushbutton is depressed during fast-forward or rewind operation. This opens the negative return lead to the tape lifter solenoid, which remains de-energized as long as the pushbutton is held down; therefore tape will contact the heads, and monitoring is possible.

5.1.7.5 Record Mode

To initiate the record mode, the tape is placed in motion in the play mode, and then the record pushbutton pressed to energize the record relays.

When any record relay is energized, as shown in Fig. 6-21, contact set 4-12-8 of that relay makes a return connection to the transport.

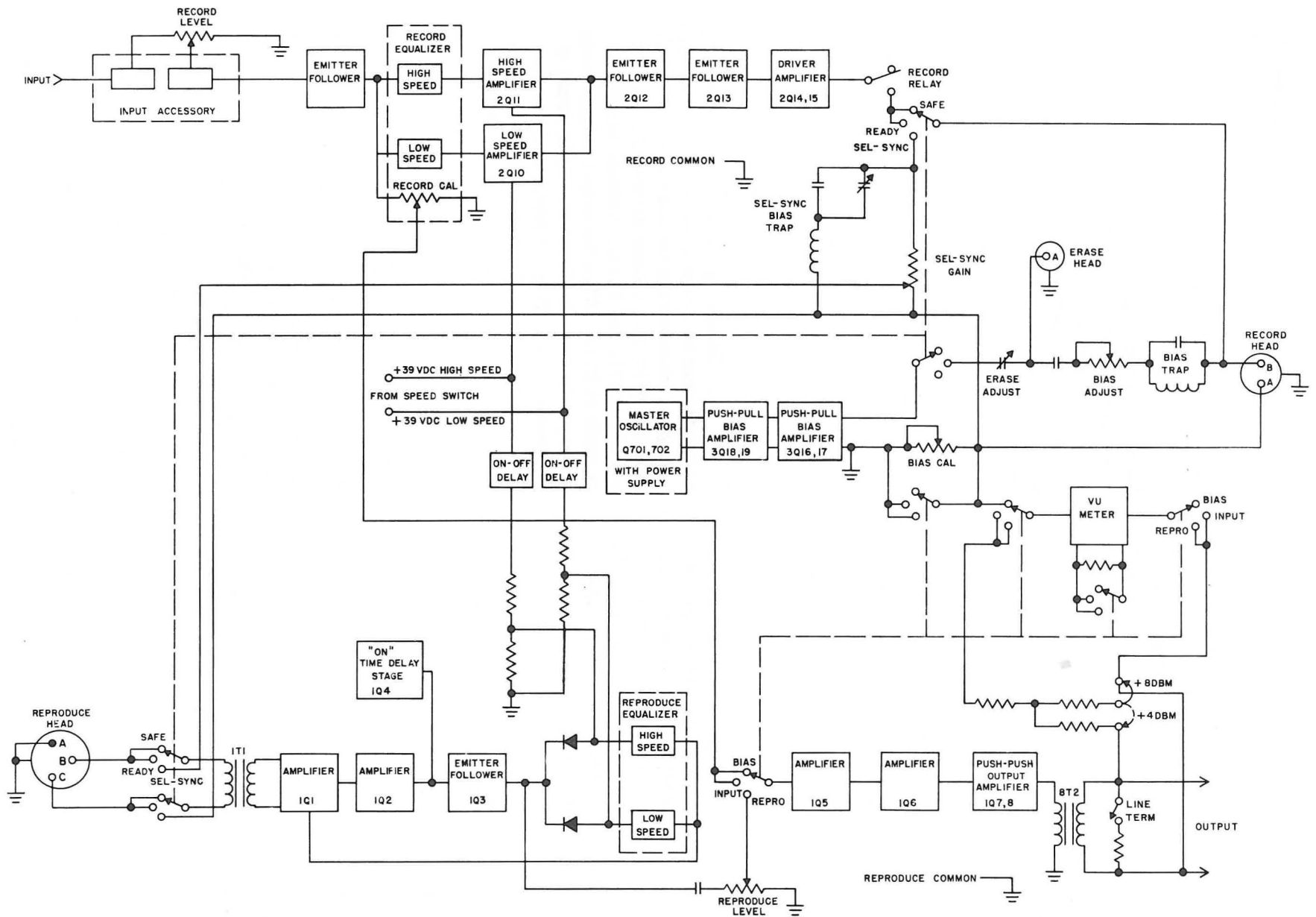

Fig. 5-2. Block Diagram

Since transistor Q601 must conduct to allow the fast-forward, rewind, or edit modes to be entered, it conducts during those modes. In the record mode, however, the record relay holding current places a bias on transistor Q602 causing it to conduct. When Q602 is conducting, Q601 is biased to cutoff, therefore the edit, rewind, and fast-forward modes are locked out when the unit is recording.

5.1.8 Tape Scrape-Flutter

Tape scrape-flutter can be likened to the drawing of a bow across a violin string. The string will vibrate at its resonant frequency, which is determined by the 'free' length of the string, its tension, and its size.

On a tape transport, the magnetic head acts as the bow, and the tape as the violin string, so instead of drawing a bow across a string, the tape is drawn across the head. As it moves across the head the tape will vibrate at its resonant frequency. For a given tape and tension, that frequency depends upon the 'free' length of tape between the reel idler and the capstan. This frequency is usually in the range to which the human ear is most sensitive, from 1,000 to 6,000 Hz. For example, the scrape-flutter frequency on this transport without a tape scrape-flutter idler would be about 3,500 Hz.

When a rotating idler (such as the supplied tape scrape-flutter idler) is installed in the tape path approximately midway between the reel idler and capstan, the length of 'free' (un-supported) tape is halved. This practically doubles the scrape-flutter frequency to about 7,000 Hz, which is out of the range of greatest ear sensitivity. This higher frequency also automatically drops the volume. The effect of tape scrape-flutter is therefore reduced to about 25% of its former value.

If the second tape scrape-flutter idler (optional accessory) is installed on the transport, the flutter frequency is again raised--to approximately 10,000 Hz. This, and the additional drop in volume practically nullifies tape scrape-flutter.

5.2 ELECTRONIC CIRCUITS (See Figure 5-2)

5.2.1 Power Supply

Components for the regulated power supply in a recorder/reproducer are mounted on the same printed circuit board as those for the bias oscillator (see Fig. 6-22). For the reproducer, the bias oscillator is omitted (see Fig. 6-23). In either case, the printed circuit board plugs into the electronics power supply box (at the back of the transport). A series-regulating transistor (Q705) is mounted on the power supply chassis.

A-C power is delivered to the power supply from the tape transport. It is fused by fuse F701, rectified by the bridge rectifier formed by diodes CR701 through CR704, and filtered by resistor R706 and capacitor C707. It then is connected to the voltage regulator.

In the regulator, a reference voltage is established by Zener diode VR702. A sampling voltage is taken across the output line at variable resistor R712 (in a voltage divider circuit with resistors R711 and R712). Voltage adjustment is made at R712. When the output voltage tends to vary with load, it affects the conductance of transistor Q706. This, in turn, changes the conductance of transistors Q704 and Q705 (connected in a Darlington circuit) to maintain the voltage at normal level.

Transistor Q703 acts as a constant-current source for Q704 and Q706. Overload protection is also provided with this transistor, in conjunction with diode CR707 and resistor R709. If a serious overload occurs, the increased voltage across R709 also appears across resistor R708, through diode CR707. This will bias transistor Q703 to cutoff. Deprived of their current source, Q704 and Q706 will cutoff, removing the bias on Q705. The power supply will thus automatically shut off until the overload is removed.

The regulator is adjusted to provide a +39 (-1/2+1) vdc to the electronic assemblies. It is also connected back to the tape transport speed selector which switches the +39 vdc (through the power supply box) to one of the transport's two equalization-switching circuits.

A power-distribution and fusing diagram is provided in Fig. 6-19.

5.2.2 Bias Oscillator and Amplifier Circuits

NOTE

These circuits are provided only with recorder/reproducer systems.

The master bias oscillator is mounted on the same card as the electronic power supply (see Fig. 6-22). This is simply a capacitively-coupled push-pull oscillator, operating at a nominal frequency of 150,000 Hz. Operating power of +39 vdc is direct from the power supply, so the oscillator operates continuously when power is on. Its transformer-coupled output is delivered to the bias amplifier in each record/reproduce unit.

Two push-pull bias amplifier stages are mounted on a plug-in circuit board for each record/reproduce unit. Operating power is applied to these stages through contact set 3-7-11 of the energized record relay K1. The circuits, therefore, operate only during the record mode.

The push-pull bias input from the oscillator, is connected at pins 1 (shield, 2, and 3 of receptacle 4J11 (see Fig. 6-24). It is connected to the amplifier circuit board, and routed to the bases of transistor 3Q18 and 3Q19. This circuit and the following circuit (3Q16 and 3Q17), together, provide normal push-pull amplification of the bias frequency. They operate at clipping level, to eliminate the need for a bias symmetry adjustment (an unsymmetrical bias waveform causes magnetization of the record heads, and high second-harmonic distortion). A fully acceptable sine wave output is obtained when transformer 3T3 is resonated with the record head, by adjusting the bias-adjust control (3C40) to peak the erase head current. The output is also taken through bias-adjust resistor 3R80, routed through the bias trap of capacitor 5C35 and inductor 5L2, and then mixed with the record signal before proceeding to the record head. A third output is through bias-calibrate resistor 3R44, through the output-selector switch, and then to the VU meter. A contact set on the output-selector switch shorts the bias-calibrate

resistor 3R44, except when the switch is at BIAS; this removes the rf signal from the line, to reduce rf induction into other circuits during the record or reproduce modes.

5.2.3 Record Amplifier Circuit

A schematic diagram of the record amplifier circuit is given in Fig. 6-24. The record amplifier is provided only with recorder/reproducer systems.

The signal to be recorded is connected to input connector 4J7, and then is routed through the input accessory (or dummy plug) in receptacle 4J8. Receptacle 4J8 is wired so that during optional microphone preamplifier use, the record-level control is connected between the two stages in the preamplifier. This effectively makes the preamplifier a variable-gain amplifier for use with most types of professional-type microphones.

From the input accessory socket, the signal enters the plug-in board circuit and emitter-follower stage 2Q9. From there it proceeds to the plug-in record equalizer circuit. The record calibrate control, 11R108, is on the equalizer board but is connected before equalization is applied. From that control, the signal (through output-selector switch contacts) to stage 1Q5 in the reproduce amplifier circuit. It proceeds through the reproduce circuit to the output line and the VU meter, for record monitoring and record level measurement (refer to paragraph 5.2.4).

The high-speed and low-speed equalizers receive the signal from stage 2Q9. Each equalization circuit consists of a variable capacitor (11C53 for low speed, 11C54 for high speed) in parallel with a fixed resistor (2R51 for low speed, 2R52 for high speed). The capacitor is then adjusted to provide the correct high-frequency response.

From the equalizer, the signal goes through one of the two equalizer amplifiers, 2Q10 or 2Q11. If low speed is selected, +39 vdc is applied to pin 6 of receptacle 4J11. This voltage is applied, through resistor 2R64, to the emitter circuit of 2Q11, biasing that transistor to cutoff. In low speed, therefore, transistor 2Q10 conducts

and amplifies the signal. When high speed is selected, the +39 vdc is applied to pin 7 of 4J11. The voltage is connected to cutoff transistor 2Q10, and stage 2Q11 thus acts as the high-speed equalization amplifier. A low frequency boost is obtained from 2R54 and 2C25, for 2Q10; and from 2R59 and 2C27, for 2Q11.

From the equalizer amplifier the signal goes through two emitter-follower stages, 2Q12 and 2Q13, to the output-driver stage formed by 2Q14 and 2Q15. The output-driver stage is a high-impedance, constant-current, amplifier. Transistor 2Q15 acts as an active-load resistance for the collector of 2Q14, thus providing a relatively low d-c resistance and a relatively high a-c resistance. In the audio frequency range, therefore, transistor 2Q14 impedance is then high enough to provide the constant-current source for the record head, yet allows full utilization of the available d-c operating voltage.

The signal, through circuit board connectors 7 and 8, proceeds through the record-relay contact-set 1-5-9. It is mixed with the bias frequency, following the bias trap (5C35 and 5L2), and then proceeds through the record-selector switch (in the READY position) to the record head.

Record relay 4K1 is energized by pushing the transport RECORD pushbutton after initiating the play mode. It is held energized (refer to Fig. 6-21) by contacts of the play relay (in the tape transport circuit) through resistor R601. Energizing voltage is connected at pin 4, and the holding voltage at pin 10, of receptacle 4J11. Contact set 1-5-9, when energized, removes record amplifier output from ground, and routes that output to the record head.

Diode 4CR6, in the record relay circuit, restricts the record mode to units set to READY, when the RECORD pushbutton was pressed. Therefore, a record/reproduce unit previously set to SAFE (on Sel Sync) will not then record, when reset to READY.

5.2.4 Reproduce Amplifier Circuit

The reproduce circuit for record/reproduce units and reproduce modules is essentially the same except that no VU meter is

supplied with the latter. Refer to schematic diagrams 6-24 (recorder/reproducer) and 6-25 (reproducer). A monitor jack for reproducers is mounted on the back panel of the module.

From the reproduce head, the reproduced signal goes through the record-selector switch to the reproduce circuit board and transformer 1T1.

From the input transformer, the signal goes to the base of amplifier stage 1Q1; base bias on this transistor is derived from the current through resistor 1R4, which is filtered by capacitor 1C1. Another amplifier stage, 1Q2, follows 1Q1. D-C feedback is applied through 1R3 (bypassed by 1C2) from the collector of Q2 to the collector of Q1. Collector voltage for both 1Q1 and 1Q2 comes through transistor 1Q4; so those stages cannot operate until 1Q4 conducts. A time-constant circuit (1C8 and 1R38) delays conduction of Q4, so that power application does not peak the VU meter indicator, or cause popping sounds at the output.

The signal from 1Q2 proceeds through the emitter-follower, 1Q3, emitter to the reproduce equalization circuits and back to the emitter of Q1. Equalization is selected by energizing diode 1CR2 (low speed) or 1CR1 (high speed) to allow them to pass the signal. At low speed, +39 vdc goes to pin 6 of receptacle 4J11. At high speed, the +39 vdc goes to pin 7 of that receptacle. A time-constant circuit is inserted in both +39 lines, again, to protect the VU meter and prevent popping sounds when the speed is switched.

When a speed is first selected, the "on" time-constant is determined by a 100 mfd and a 35 mfd capacitor contained in capacitor 9C9. When that speed is turned off (other speed selected) the 100 mfd capacitor is out of the circuit, and the delay is determined by the 35 mfd capacitor. Thus the "on" time-delay, when a speed is selected, is greater than the "off" time-delay for the same speed.

If low speed is selected, the positive voltage from the time delay circuit is connected through 1R15 to diode 1CR2, biasing that diode so that it will conduct the signal from the emitter of 1Q3 to the low-speed equalizer. If

high speed is selected, the positive voltage, connected through 1R14, causes diode 1C11 to conduct the signal to the high-speed equalizer. Thus the low-speed or the high-speed equalizer is connected from the emitter circuit of 1Q3 back to the emitter of 1Q1.

From the emitter of 1Q3 the equalized signal is also routed through capacitor 1C7, the reproduce level control, and the output-selector switch, to the base of amplifier stage 1Q5 (where the record monitor is connected, refer to paragraph 5.2.3). Capacitor 1C10 in the base circuit of 1Q5, provides an rf bypass, while 1C12 decouples the dc bias to stage 1Q5. Capacitor 1C14, in the collector circuit, is inserted to permit attaining high levels without clipping.

After 1Q5, the signal is connected to stage 1Q6, which provides drive for the push-push output stage formed by the complementary pair of transistors 1Q7 and 1Q8. The output signal leaves the circuit board at the emitter junction of those two transistors.

The output signal is connected through the phones jack transformer 8T2 to the output connector. Line-termination switch 4S3 connects resistor 8R33 across the output line, to terminate the equipment during checks and adjustments.

The secondary of the output transformer is connected to the VU meter through a strapping circuit for a +8 dBm or a +4 dBm normal operating level (see Fig. 5-3). Equipment strapped for a +8 dBm output has resistors 8R34 and 8R35 connected as a voltage divider across the transformer, with 8R36 connected to their junction for the VU meter input.

Strapping for +4 dBm has resistors 8R34 and 8R35 connected in parallel on one side of the line, and series resistor 8R36 in the input circuit to the VU meter.

5.2.5 Sel-Sync Circuit

The Sel-Sync circuit is shown between the record and reproduce heads in Fig. 6-24. With the record-selector switch at SEL-SYNC, the reproduce and record heads are disconnected from their amplifiers, and the record head is

connected to the reproduce amplifier. The record head reproduces the signal from the tape and delivers it to the reproduce amplifier for amplification for monitoring purposes.

A Sel-Sync gain control (4R43) sets the monitoring signal level. An adjustable bias-trap (4C18, 4C38, and 4L1) prevents bias leakage from a nearby channel that is recording. Other contact sets of the record-selector switch open the bias amplifier circuit to the record head, and the negative return circuit to the record relay.

In the Sel Sync mode, therefore, the record head acts as a reproduce head for monitoring purposes. Another record head in the same stack (on a different track) can then be used to record that track synchronously with the first.

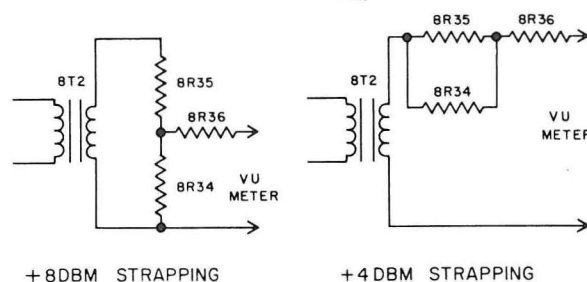

Fig. 5-3. Strapping Circuit, Simplified

SECTION VI

PARTS LISTS AND DRAWINGS

PARTS LISTS AND DRAWINGS

6.1 INTRODUCTION

The AG-440B/445B parts lists and drawings in this section are in the following order, with tab pages for easy reference:

- a. System
- b. Heads

- c. Transport
- d. Transport Control
- e. Electronics
- f. Accessories and Miscellaneous

A numerical index of main components is given below:

<u>NUMBER</u>	<u>PAGE</u>	<u>TITLE</u>
4010066B	6-41	Mic. Preamplifier
4010080D	6-40	Remote Control
4010128D	6-4E	Transport, 1-inch
4010131E	6-2/3	Recorder/Reproducer, 1-channel
4010132D	6-4/4A	Recorder/Reproducer, 2-channel
4010134E	6-4B	Recorder/Reproducer, 4-channel
4010141D	6-4C	Reproducer, 1-channel
4010142C	6-4D	Reproducer, 2-channel
4010144C	6-4D	Reproducer, 4-channel
4020150K	6-35	Reproduce Module
4020260AA	6-29	Electronics
4020269D	6-34	Record Equalizer
4020270C	6-34	Reproduce Equalizer
4020271AF	6-12&6-13/14	Tape Transport
4020272P	6-5&6-6	Heads, 1/4-inch Tape
4020273N	6-7&6-8	Heads, 1/2-inch Tape
4020274H	6-27&6-28	Power Supply
4020293J	6-21&6-22	Control Box
4030259E	6-15	Tape Lifter
4030264F	6-18	Brake Assembly
4030297C	6-16	Takeup Assembly
4030298C	6-17	Rewind Assembly
4040955C	6-11	Scrape-Flutter Idler
4040970G	6-19	Reel Idler
4040993E	6-20	Drive Motor
4050416A	6-45	Power Cable
4050432J	6-27A	Regulator/Oscillator
4050433G	6-33&6-30	Bias Amplifier
4050434E	6-31	Record Amplifier
4050435P	6-31&6-32	Reproduce Amplifier
4050438G	6-37	Electronics Panel, Front
4050439S	6-36	Electronics Panel, Rear
4050440C	6-39	Capacitor Bracket
4050441C	6-38	Electronics Panel, R. H.
4050442B	6-44	Electronics Cable
4050446C	6-9	Head Connector
4050447F	6-10	Head Cable Box
4050448D	6-10	Head Cable Box
4050472B	6-23	Record/Tape Lift Delay PWB
4840039E	6-28	Power Supply Schematic, Repro.
4840168G	6-27	Power Supply Schematic, R/R
4840169P	6-30	Electronics Schematic, R/R
4840176B	6-35	Electronics Schematic, Repro.
4840183C	6-24&6-25	Transport Schematic and Components
Figure 6-21	6-26	Power Supply Diagram
Figure 6-32	6-42	Response Curves (Sh. 1)
Figure 6-33	6-43	Response Curves (Sh. 2)

TYPE* AND DASH NUMBER												MODEL AG-440B														
-01	7 1/2-15, 60 Hz, UFT	-02	7 1/2-15, 50 Hz, UFT	-03	7 1/2-15, 60 Hz, CFT	-04	7 1/2-15, 50 Hz, CFT	-05	7 1/2-15, 60 Hz, PFT	-06	7 1/2-15, 50 Hz, PFT	-07	7 1/2-15, 60 Hz, UHT	-08	7 1/2-15, 50 Hz, UHT	-09	7 1/2-15, 60 Hz, CHT	-10	7 1/2-15, 50 Hz, CHT	-11	7 1/2-15, 60 Hz, PHT	-12,	7 1/2-15, 50 Hz, PHT	TAPE RECORDER/REPRODUCER 7-1/2 - 15 ips, Single Channel Ampex 4010131-01/12 (Ref. E)		
Qty Req'd Per Dash Number												DESCRIPTION		Ampex Part No.												
1	1	1	1	1	1	1	1	1	1	1	1	1	1	1	1	1	1	1	1	1	1	1	1	1	Console Assy	4020084-06
1	1	1	1	1	1	1	1	1	1	1	1	1	1	1	1	1	1	1	1	1	1	1	1	1	Electronics Assy (without equalizers)	4020260-10
1	1	1	1	1	1	1	1	1	1	1	1	1	1	1	1	1	1	1	1	1	1	1	1	1	Equalizer Assy, record, 7 1/2-15 NAB	4020269-01
																									Equalizer Assy, record, 3 3/4-7 1/2 NAB	4020269-02
1	1	1	1	1	1	1	1	1	1	1	1	1	1	1	1	1	1	1	1	1	1	1	1	1	Equalizer Assy, reproduce NAB	4020270-01
1		1		1		1		1		1		1		1		1		1		1		1		1	Transport Assy, 7 1/2-15, 60 Hz	4020271-13
		1		1		1		1		1		1		1		1		1		1		1		1	Transport Assy, 7 1/2-15, 50 Hz	4020271-14
1	1	1	1	1	1	1	1	1	1	1	1	1	1	1	1	1	1	1	1	1	1	1	1	1	Head Assy, full track	4020272-01
													1	1	1	1	1	1	1	1	1	1	1	1	Head Assy, 2-track	4020272-02
1	1	1	1	1	1	1	1	1	1	1	1	1	1	1	1	1	1	1	1	1	1	1	1	1	Power Supply Assy	4020274-03
			2	2													2	2							Knob Assy, editing	4030145-10
2	2																								Knob Assy, reel	4040492-10
							1	1																	Panel Assy, backing	4040945-01
1	1	1	1	1	1	1	1	1	1	1	1	1	1	1	1	1	1	1	1	1	1	1	1	1	Idler Assy, scrape-flutter	4040955-01
1	1	1	1	1	1	1	1	1	1	1	1	1	1	1	1	1	1	1	1	1	1	1	1	1	Cable Assy, power	4050416-02
1	1	1	1	1	1	1	1	1	1	1	1	1	1	1	1	1	1	1	1	1	1	1	1	1	Cable Assy, electronics interconnect	4050442-01
1	1	1	1	1	1	1	1	1	1	1	1	1	1	1	1	1	1	1	1	1	1	1	1	1	Mounting Box Assy, head cable	4050447-06
2	2	2	2	2	2	2	2	2	2	2	2	2	2	2	2	2	2	2	2	2	2	2	2	2	Knob, reel holddown	4100137-10
																									Case Assy, transport	4150329-01
																									Case Assy, single & dual elect. 7"	4150339-02
																									Panel, front facing (blank)	4290620-01
			1	1																					Shield, resistor (control box)	4290643-01
1	1																								Shield, resistor (control box)	4290659-01
1	1	1	1	1	1	1	1	1	1	1	1	1	1	1	1	1	1	1	1	1	1	1	1	1	Transformer, input bridging	4580200-01
1	1	1	1	1	1	1	1	1	1	1	1	1	1	1	1	1	1	1	1	1	1	1	1	1	Shield, P/B head connector	4600008-10
1	1	1	1	1	1	1	1	1	1	1	1	1	1	1	1	1	1	1	1	1	1	1	1	1	Reel Assy, tape	4690003-10
1	1	1	1	1	1	1	1	1	1	1	1	1	1	1	1	1	1	1	1	1	1	1	1	1	Manual, instruction	4890301
1	1	1	1	1	1	1	1	1	1	1	1	1	1	1	1	1	1	1	1	1	1	1	1	1	Nutdriver, modified	4930504-01
1	1	1	1	1	1	1	1	1	1	1	1	1	1	1	1	1	1	1	1	1	1	1	1	1	Connector, plug, female, 3-pin	144-003
1	1	1	1	1	1	1	1	1	1	1	1	1	1	1	1	1	1	1	1	1	1	1	1	1	Connector, plug, male, 3-pin	145-009

*CODE: C-Cased
 FT-Full Track
 HT-Half Track
 P-Portable
 U-Uncased

TYPE* AND DASH NUMBER												MODEL AG-440B	
-13	-14	-15	-16	-17	-18	-19	-20	-21	-22	-23	-24	TAPE RECORDER/REPRODUCER 3-3/4 - 7-1/2 ips, Single Channel Ampex 4010131-13/24 (Ref. E)	
3 3/4-7 1/2, 60 Hz UFT	3 3/4-7 1/2, 50 Hz UFT	3 3/4-7 1/2, 60 Hz CFT	3 3/4-7 1/2, 50 Hz CFT	3 3/4-7 1/2, 60 Hz PFT	3 3/4-7 1/2, 50 Hz PFT	3 3/4-7 1/2, 60 Hz UHT	3 3/4-7 1/2, 50 Hz UHT	3 3/4-7 1/2, 60 Hz CHT	3 3/4-7 1/2, 50 Hz CHT	3 3/4-7 1/2, 60 Hz PHT	3 3/4-7 1/2, 50 Hz PHT	*CODE: C-Cased FT-Full Track HT-Half Track P-Portable U-Uncased	
Qty Req'd Per Dash Number												DESCRIPTION	Ampex Part No.
		1	1					1	1			Console Assy	4020084-06
1	1	1	1	1	1	1	1	1	1	1	1	Electronics Assy (without equalizers)	4020260-10
												Equalizer Assy, record, 7 1/2-15 NAB	4020269-01
1	1	1	1	1	1	1	1	1	1	1	1	Equalizer Assy, record, 3 3/4-7 1/2 NAB	4020269-02
1	1	1	1	1	1	1	1	1	1	1	1	Equalizer Assy, reproduce NAB	4020270-01
												Transport Assy, 3 3/4-7 1/2, 60 Hz	4020271-15
	1		1		1		1		1		1	Transport Assy, 3 3/4-7 1/2, 50 Hz	4020271-16
1	1	1	1	1	1							Head Assy, full track	4020272-01
						1	1	1	1	1	1	Head Assy, 2-track	4020272-02
1	1	1	1	1	1	1	1	1	1	1	1	Power Supply Assy	4020274-03
		2	2					2	2			Knob Assy, editing	4030145-10
2	2			2	2	2	2			2	2	Knob Assy, reel	4040492-10
			1	1						1	1	Panel Assy, backing	4040945-01
1	1	1	1	1	1	1	1	1	1	1	1	Idler Assy, scrape-flutter	4040955-01
1	1	1	1	1	1	1	1	1	1	1	1	Cable Assy, power	4050416-02
1	1	1	1	1	1	1	1	1	1	1	1	Cable Assy, electronics interconnect	4050442-01
1	1	1	1	1	1	1	1	1	1	1	1	Mounting Box Assy, head cable	4050447-06
2	2	2	2	2	2	2	2	2	2	2	2	Knob, reel holddown	4100137-10
				1	1					1	1	Case Assy, transport	4150329-01
				1	1					1	1	Case Assy, single & dual elect. 7"	4150330-02
										1	1	Panel, front facing (blank)	4290620-01
		1	1					1	1			Shield, resistor (control box)	4290643-01
1	1		1	1	1	1	1		1	1		Shield, resistor (control box)	4290659-01
1	1	1	1	1	1	1	1	1	1	1	1	Transformer, input bridging	4580200-01
1	1	1	1	1	1	1	1	1	1	1	1	Shield, P/B head connector	4600008-10
1	1	1	1	1	1	1	1	1	1	1	1	Reel Assy, tape	4690003-10
1	1	1	1	1	1	1	1	1	1	1	1	Manual, instruction	4890301
1	1	1	1	1	1	1	1	1	1	1	1	Nutdriver, modified	4930504-01
1	1	1	1	1	1	1	1	1	1	1	1	Connector, plug, female, 3-pin	144-003
1	1	1	1	1	1	1	1	1	1	1	1	Connector, plug, male, 3-pin	145-009

TYPE* AND DASH NUMBER	
Two-Track Heads	
-01	7½-15 60 Hz U
-02	7½-15 50 Hz U
-03	7½-15 60 Hz C
-04	7½-15 50 Hz C
-05	7½-15 60 Hz P
-06	7½-15 50 Hz P
-07	3 3/4-7½ 60 Hz U
-08	3 3/4-7½ 50 Hz U
-09	3 3/4-7½ 60 Hz C
-10	3 3/4-7½ 50 Hz C
-11	3 3/4-7½ 60 Hz P
-12	3 3/4-7½ 50 Hz P

MODEL AG-440B, DUAL-CHANNEL
 TAPE RECORDER/REPRODUCER
 Ampex 4010132 (Ref. D)

* CODE: C-Cased
 P-Portable
 U-Uncased

(Page 1 of 2)

Quantity Required Per Dash Number												DESCRIPTION	Ampex Part No.
2	2	1	2	2	2	2	2	2	2	2	2	Console Assy	4020084-07
2	2	2	2	2	2	2	2	2	2	2	2	Electronics Assy, without Equalizers	4020260-10
												Equalizer Assy, Record 7½-15 NAB	4020269-01
2	2	2	2	2	2	2	2	2	2	2	2	Equalizer Assy, Record 3 3/4-7½ NAB	4020269-02
1		1		1								Equalizer Assy, Reproduce NAB	4020270-01
	1		1									Transport Assy, 7½-15 60 Hz	4020271-09
				1								Transport Assy, 7½-15 50 Hz	4020271-10
					1							Transport Assy, 3 3/4-7½ 60 Hz	4020271-11
1	1	1	1	1	1	1	1	1	1	1	1	Transport Assy, 3 3/4-7½ 50 Hz	4020271-12
												Head Assembly, Two-Track	4020272-02
1	1	1	1	1	1	1	1	1	1	1	1	Power Supply Assy	4020274-03
												Knob Assy, Editing	4030145-10
2	2			2	2	2	2	2	2	2	2	Knob Assy, Reel	4040492-10
1	1	1	1	1	1	1	1	1	1	1	1	Scrape Flutter Idler Assy	4040955-01
1	1	1	1	1	1	1	1	1	1	1	1	Cable Assy, Power	4050416-02
2	2	2	2	2	2	2	2	2	2	2	2	Cable Assy, Electronics Interconnect	4050442-01
1	1	1	1	1	1	1	1	1	1	1	1	Box Assy, Head Cable Mounting	4050447-07
2	2	2	2	2	2	2	2	2	2	2	2	Knob, Reel Holddown	4100137-10
				1	1							Case Assy, Transport	4150329-01
				1	1							Case Assy, Single & Dual Elect. 7"	4150330-02
		1	1					1	1			Shield, Resistor (Control Box)	4290643-01
1	1			1	1	1	1	1	1	1	1	Shield, Resistor (Control Box, Uncased & Portable)	4290659-01
2	2	2	2	2	2	2	2	2	2	2	2	Transformer, Input Bridging	4580200-01
2	2	2	2	2	2	2	2	2	2	2	2	Shield, P/B Head Connector	4600008-10
1	1	1	1	1	1	1	1	1	1	1	1	Reel Assy	4690003-10
1	1	1	1	1	1	1	1	1	1	1	1	Instruction Manual	4890301
1	1	1	1	1	1	1	1	1	1	1	1	Nutdriver, Modified	4930504-01
2	2	2	2	2	2	2	2	2	2	2	2	Connector, Plug, female, 3-pin	144-003
2	2	2	2	2	2	2	2	2	2	2	2	Connector, Plug, male, 3-pin	145-009

MODEL AG-440B, DUAL-CHANNEL
TAPE RECORDER/REPRODUCER

Ampex 4010132 (Ref. D)

(Page 2 of 2)

TYPE* AND DASH NUMBER Four-Position Heads										
-13	7 1/2-15	60 Hz	U							
-14	7 1/2-15	50 Hz	U							
-15	7 1/2-15	60 Hz	C							
-16	7 1/2-15	50 Hz	C							
-17	7 1/2-15	60 Hz	P							
-18	7 1/2-15	50 Hz	P							
-19	3 3/4-7 1/2	60 Hz	U							
-20	3 3/4-7 1/2	50 Hz	U							
-21	3 3/4-7 1/2	60 Hz	C							
-22	3 3/4-7 1/2	50 Hz	C							
-23	3 3/4-7 1/2	60 Hz	P							
-24	3 3/4-7 1/2	50 Hz	P							

CODE: C-Cased
P-Portable
U-Uncased

Quantity Required Per Dash Number											DESCRIPTION	Ampex Part No.
2	2	1	1	2	2	2	2	2	2	2	Console Assy	4020084-07
2	2	2	2	2	2	2	2	2	2	2	Electronics Assy, without Equalizers	4020260-10
2	2	2	2	2	2	2	2	2	2	2	Equalizer Assy, Record 7 1/2-15 NAB	4020269-01
2	2	2	2	2	2	2	2	2	2	2	Equalizer Assy, Record 3 3/4-7 1/2 NAB	4020269-02
2	2	2	2	2	2	2	2	2	2	2	Equalizer Assy, Reproduce NAB	4020270-01
1	1	1	1	1	1	1	1	1	1	1	Transport Assy, 7 1/2-15 60 Hz	4020271-09
	1		1		1						Transport Assy, 7 1/2-15 50 Hz	4020271-10
						1		1		1	Transport Assy, 3 3/4-7 1/2 60 Hz	4020271-11
							1		1	1	Transport Assy, 3 3/4-7 1/2, 50 Hz	4020271-12
1	1	1	1	1	1	1	1	1	1	1	Head Assembly, 4-Position	4020272-03
1	1	1	1	1	1	1	1	1	1	1	Power Supply Assy	4020274-03
		2	2					2	2		Knob Assy, Editing	4030145-10
2	2			2	2	2	2	2	2	2	Knob Assy, Reel	4040492-10
1	1	1	1	1	1	1	1	1	1	1	Scrape Flutter Idler Assy	4040955-01
1	1	1	1	1	1	1	1	1	1	1	Cable Assy, Power	4050416-02
2	2	2	2	2	2	2	2	2	2	2	Cable Assy, Electronics Interconnect	4050442-01
1	1	1	1	1	1	1	1	1	1	1	Box Assy, Head Cable Mounting	4050447-10
2	2	2	2	2	2	2	2	2	2	2	Knob, Reel Holddown	4100137-10
				1	1					1	Case Assy, Transport	4150329-01
				1	1					1	Case Assy, Single & Dual Elect. 7"	4150330-02
1	1	1	1	1	1	1	1	1	1	1	Shield, Resistor (Control Box)	4290643-01
2	2	2	2	2	2	2	2	2	2	2	Shield, Resistor (Control Box, Uncased & Portable)	4290659-01
2	2	2	2	2	2	2	2	2	2	2	Transformer, Input Bridging	4580200-01
1	1	1	1	1	1	1	1	1	1	1	Shield, P/B Head Connector	4600008-10
1	1	1	1	1	1	1	1	1	1	1	Reel Assy	4690003-10
1	1	1	1	1	1	1	1	1	1	1	Instruction Manual	4890301
1	1	1	1	1	1	1	1	1	1	1	Nutdriver, Modified	4930504-01
2	2	2	2	2	2	2	2	2	2	2	Connector, Plug, female, 3-pin	144-003
2	2	2	2	2	2	2	2	2	2	2	Connector, Plug, male, 3-pin	145-009

TYPE* AND DASH NO.							MODEL AG-440B FOUR-CHANNEL TAPE RECORDER/REPRODUCER Ampex 4010134 (Ref. E)												
-01	7 1/2-15	60 Hz, U	-02	7 1/2-15	50 Hz, U	-03	7 1/2-15	60 Hz, C	-04	7 1/2-15	50 Hz, C	-05	7 1/2-15	60 Hz, P	-06	7 1/2-15	50 Hz, P	*CODE: C-Cased P-Portable U-Uncased	
Qty Req'd Per Dash Number							DESCRIPTION	Ampex Part No.											
			1			1												Console Assy	4020084-09
4	4	4	4	4	4	4	4	4	4	4	4	4	4	4	4	4	4	Electronics Assy, without Equalizers	4020260-11
4	4	4	4	4	4	4	4	4	4	4	4	4	4	4	4	4	4	Equalizer Assy, Record 7 1/2-15 NAB	4020269-01
4	4	4	4	4	4	4	4	4	4	4	4	4	4	4	4	4	4	Equalizer Assy, Reproduce NAB	4020270-01
1			1			1			1			1			1			Transport Assy, 7 1/2-15 60 Hz	4020271-09
	1			1			1			1			1			1		Transport Assy, 7 1/2-15 50 Hz	4020271-10
1	1	1	1	1	1	1	1	1	1	1	1	1	1	1	1	1	1	Head Assembly, 4-Track	4020273-05
1	1	1	1	1	1	1	1	1	1	1	1	1	1	1	1	1	1	Power Supply Assy	4020274-03
			2			2			2			2			2			Knob Assy, Editing	4030145-10
2	2			2			2		2			2			2			Knob Assy, Reel	4040492-10
1	1	1	1	1	1	1	1	1	1	1	1	1	1	1	1	1	1	Scrape Flutter Idler Assy	4040955-01
1	1	1	1	1	1	1	1	1	1	1	1	1	1	1	1	1	1	Cable Assy, Power	4050416-02
4	4	4	4	4	4	4	4	4	4	4	4	4	4	4	4	4	4	Cable Assy, Electronics Interconnect	4050442-01
1	1	1	1	1	1	1	1	1	1	1	1	1	1	1	1	1	1	Box Assy, Head Cable Mounting	4050447-09
																		Case Assy, Transport	4150329-01
																		Case Assy, 3 & 4 Electronics (14")	4150331-01
			1			1												Shield, Resistor (Control box)	4290643-01
1	1			1			1			1			1					Shield, Resistor (Control box, uncased and portable)	4290659-01
4	4	4	4	4	4	4	4	4	4	4	4	4	4	4	4	4	4	Transformer, Input Bridging	4580200-01
4	4	4	4	4	4	4	4	4	4	4	4	4	4	4	4	4	4	Shield, P/B Head, Connector	4600008-10
4	4	4	4	4	4	4	4	4	4	4	4	4	4	4	4	4	4	Connector, Plug, female, 3-soc.	144-003
4	4	4	4	4	4	4	4	4	4	4	4	4	4	4	4	4	4	Connector, Plug, male, 3-pin	145-009
1	1	1	1	1	1	1	1	1	1	1	1	1	1	1	1	1	1	Nutdriver, Modified	4930504-01

TYPE* AND DASH NUMBER																																																															
-01	7-1/2-15	60 Hz	UFT	-02	7-1/2-15	50 Hz	UFT	-03	7-1/2-15	60 Hz	CFT	-04	7-1/2-15	50 Hz	CFT	-07	7-1/2-15	60 Hz	UHT	-08	7-1/2-15	50 Hz	UHT	-09	7-1/2-15	60 Hz	CHT	-10	7-1/2-15	50 Hz	CHT	-13	3-3/4-7-1/2	60 Hz	UFT	-14	3-3/4-7-1/2	50 Hz	UFT	-15	3-3/4-7-1/2	60 Hz	CFT	-16	3-3/4-7-1/2	50 Hz	CFT	-19	3-3/4-7-1/2	60 Hz	UHT	-20	3-3/4-7-1/2	50 Hz	UHT	-21	3-3/4-7-1/2	60 Hz	CHT	-22	3-3/4-7-1/2	50 Hz	CHT

MODEL AG-445B
 TAPE REPRODUCER, ONE-CHANNEL
 Ampex 4010141 (Ref. D)

*CODE: C-Cased
 FT-Full Track
 HT-Half Track
 P-Portable
 U-Uncased

Qty Req'd Per Dash Number												DESCRIPTION	Ampex Part No.		
		1	1			1	1					1	1	Console Assy	4020084-06
1	1	1	1	1	1	1	1	1	1	1	1	1	1	Reproduce Module	4020150-03
1	1	1	1	1	1	1	1	1	1	1	1	1	1	Equalizer Assy, reproduce NAB	4020270-01
1		1		1		1								Transport Assy, 7 1/2-15, 60 Hz	4020271-13
	1		1		1									Transport Assy, 7 1/2-15, 50 Hz	4020271-14
								1		1			1	Transport Assy, 3 3/4-7 1/2, 60 Hz	4020271-15
									1		1		1	Transport Assy, 3 3/4-7 1/2, 50 Hz	4020271-16
1	1	1	1					1	1	1	1			Head Assy, full track	4020272-04
				1	1	1	1					1	1	Head Assy, 2-track	4020272-05
1	1	1	1	1	1	1	1	1	1	1	1	1	1	Power Supply Assy	4020274-04
		2	2			2	2			2	2		2	Knob Assy, editing	4030145-10
1	1	1	1	1	1	1	1	1	1	1	1	1	1	Tray Assy, reproducer	4040346-02
1	1	1	1	1	1	1	1	1	1	1	1	1	1	Panel Assy, facing	4040347-01
2	2			2	2			2	2			2	2	Knob Assy, reel	4040492-10
1	1	1	1	1	1	1	1	1	1	1	1	1	1	Idler Assy, scrape-flutter	4040955-01
1	1	1	1	1	1	1	1	1	1	1	1	1	1	Cable Assy, power	4050416-02
1	1	1	1	1	1	1	1	1	1	1	1	1	1	Box Assy, head cable mounting	4050448-06
2	2	2	2	2	2	2	2	2	2	2	2	2	2	Knob, reel holddown	4100137-10
		1	1			1	1			1	1		1	Shield, resistor (control box)	4290643-01
1	1			1	1			1	1			1	1	Shield, resistor (control box)	4290659-01
1	1	1	1	1	1	1	1	1	1	1	1	1	1	Reel Assy, tape	4690003-10
1	1	1	1	1	1	1	1	1	1	1	1	1	1	Manual, Instruction	4890301
1	1	1	1	1	1	1	1	1	1	1	1	1	1	Shield, P/B head connector	4600008-10
1	1	1	1	1	1	1	1	1	1	1	1	1	1	Nutdriver, modified	4930504-01
1	1	1	1	1	1	1	1	1	1	1	1	1	1	Connector, plug, female, 3-pin	144-003

TYPE* AND DASH NUMBER								AG-445B, TWO-CHANNEL (Two and Four Track) TAPE REPRODUCER Amplex 4010142 (Ref. C)		
-01	7 1/2	-15	60 Hz	U					* CODE: C-Cased U-Uncased	
-02	7 1/2	-15	50 Hz	U						
-03	7 1/2	-15	60 Hz	C						
-04	7 1/2	-15	50 Hz	C						
-07	3	3/4-7 1/2	60 Hz							
-08	3	3/4-7 1/2	50 Hz							
-09	3	3/4-7 1/2	60 Hz							
-10	3	3/4-7 1/2	50 Hz							
Qty Req'd Per Dash Number								DESCRIPTION		Ampex Part No.
2	2	1	1	1	1	1	1	Console Assy	4020084-06	
2	2	2	2	2	2	2	2	Reproduce Module	4020150-03	
2	2	2	2	2	2	2	2	Equalizer Assy, Reproduce NAB	4020270-01	
1		1						Transport Assy, 7 1/2-15, 60 Hz	4020271-09	
	1							Transport Assy, 7 1/2-15, 50 Hz	4020271-10	
			1		1			Transport Assy, 3 3/4-7 1/2, 60 Hz	4020271-11	
1	1	1	1	1	1	1	1	Transport Assy, 3 3/4-7 1/2, 50 Hz	4020271-12	
1	1	1	1	1	1	1	1	Head Assy, 2-Ch., 2 & 4 Track	4020272-06	
		2	2		2	2		Power Supply Assy	4020274-04	
1	1	1	1	1	1	1	1	Knob Assy, Editing	4030145-10	
1	1	1	1	1	1	1	1	Tray Assy, Reproducer	4040346-02	
1	1	1	1	1	1	1	1	Facing Panel Assy	4040347-01	
2	2		2	2	2	2		Knob Assy, Reel	4040492-10	
1	1	1	1	1	1	1	1	Scrape Flutter Idler Assy	4040955-01	
1	1	1	1	1	1	1	1	Cable Assy, Power	4050416-02	
1	1	1	1	1	1	1	1	Box Assy, Head Cable Mounting	4050448-07	
2	2	2	2	2	2	2	2	Knob Reel Holddown	4100137-10	
1	1	1	1	1	1	1	1	Instruction Manual	4890301	
		1	1		1	1		Shield, Resistor (Control Box)	4290643-01	
1	1		1	1				Shield, Resistor (Control Box, Uncased)	4290659-01	
2	2	2	2	2	2	2	2	Shield, P/B Head Connector	4600008-10	
2	2	2	2	2	2	2	2	Connector Plug, female, 3-pin	144-003	
1	1	1	1	1	1	1	1	Nutdriver, Modified	493-504-01	

TYPE* AND DASH NUMBER				AG-445B, FOUR-CHANNEL TAPE REPRODUCER Amplex 4010144 (Ref. C)			
-01	7 1/2	-15	60 Hz	U	* CODE: P-Portable U-Uncased		
-02	7 1/2	-15	50 Hz	U			
-03	7 1/2	-15	60 Hz	P			
-04	7 1/2	-15	50 Hz	P			
Qty Req'd Per Dash Number				DESCRIPTION		Ampex Part No.	
4	4	4	4	1	1	Console Assy	4020084-06
4	4	4	4	4	4	Reproduce Module	4020150-03
4	4	4	4	4	4	Equalizer Assy, Reproduce NAB	4020270-01
1		1				Transport Assy, 7 1/2-15, 60 Hz	4020271-09
	1					Transport Assy, 7 1/2-15, 50 Hz	4020271-10
1	1	1	1	1	1	Head Assy, 4-Track	4020273-04
1	1	1	1	1	1	Power Supply Assy	4020274-04
		2	2			Knob Assy, Editing	4030145-10
1	1	1	1	1	1	Tray Assy, Reproducer	4040346-02
1	1	1	1	1	1	Facing Panel Assy	4040347-01
2	2		2			Knob Assy, Reel	4040492-10
1	1	1	1	1	1	Scrape Flutter Idler Assy	4040955-01
1	1	1	1	1	1	Cable Assy, Power	4050416-02
1	1	1	1	1	1	Box Assy, Head Cable Mounting	4050448-09
1	1	1	1	1	1	Reel Assy, 1/2-Tape	469003-20
1	1	1	1	1	1	Instruction Manual	4890301
		1	1			Shield, Resistor (Control Box)	4290643-01
1	1					Shield, Resistor (Control Box, Uncased & Portable)	4290659-01
4	4	4	4	4	4	Connector, Plug, female, 3-pin	144-003
4	4	4	4	4	4	Shield, P/B Head Connector	4600008-10
1	1	1	1	1	1	Nutdriver, Modified	4930504-01

MODEL AG-440B, TAPE TRANSPORT

Amplex 4010128 (Ref. D)

4890301

TYPE* AND DASH NO.				Qty Reqd Per Dash Number	DESCRIPTION	Amplex Part No.
-03 7-1/2 - 15 60 Hz	-04 7-1/2 - 15 50 Hz	-05 3-3/4 - 7-1/2 60 Hz	-06 3-3/4 - 7-1/2 50 Hz			
1	1	1	1	1	Idler Assembly, Scrape Flutter	4040955-01
1	1	1	1	1	Shield, Resistor, Control Box	4290659-01
1	1	1	1	1	Screw, #8-32 x 1, Pan Head, Cross-Recessed	471-084
1	1	1	1	1	Washer, #8, Flat	501-010
1	1	1	1	1	Lockwasher, #8, Spring	502-004
2	2	2	2	2	Nut, #8-32, "Keps"	496-006
1	1	1	1	1	Jiffy Bag, #7, 14 x 20	718-022
1	1	1	1	1	Cable Assembly, Power	4050416-02
1	1	1	1	1	Packaging Assembly	1206811-01
1					Tape Transport Assembly, 7-1/2 - 15 60 Hz	4020271-13
	1				Tape Transport Assembly, 7-1/2 - 15 50 Hz	4020271-14
		1			Tape Transport Assembly, 3-3/4 - 7-1/2 60 Hz	4020271-15
			1		Tape Transport Assembly, 3-3/4 - 7-1/2 50 Hz	4020271-16

SECTION VI

HEADS

HEAD ASSEMBLY 1/4" TAPE

CATALOG NO. 4020272

SHEET 1 OF 1

NHA 4010071, 4010072

ITEM NO.	AMPEX PART NO.	VENDOR OR MIL. NO.	SCHEMATIC REFERENCE	PART DESCRIPTION	QUANTITY REQUIRED PER VERSION							
					-01	-02	-03	-04	-05	-06	-07	
1	4050446-01			HEAD CONNECTOR ASSEMBLY	3			1				
2	4050446-02			HEAD CONNECTOR ASSEMBLY		3	4		1	2	3	
3	4270167-10			SPRING, Head	4	4	4	2	2	2		
4	4350011-01			KNOB			1			1		
5	4350038-01			OVERLAY ASSEMBLY, Head Housing	1	1		1	1		1	
6	4350038-02			OVERLAY ASSEMBLY, Head Housing			1			1		
7	4350016-01			SPACER, Head, 1/4" tape	1	1	1	1	1	1	1	1
9	4350019-01			SPACER, Erase Head	1	1	1					
10	4350021-01			SHIELD CAN ASSEMBLY, Record Position #2			1					
11	4350022-01			SHIELD CAN ASSEMBLY, Record Position #3	1	1					1	
12	4350023-01			SHIELD CAN ASSEMBLY, Playback Position, #3			1			1		
13	4350024-01			SHIELD CAN ASSEMBLY, Playback Position, #4	1	1	1	1	1	1	1	1
14	4350029-05			GATE ASSEMBLY, Head	1	1					1	
15	4350029-06			GATE ASSEMBLY, Head			1					
16	4350030-01			TAPE GUIDE ASSEMBLY, 1/4"	2	2	2	2	2	2	2	2
17	4210313-01			SHAFT, Switch			1			1		
18	4350035-01			SPRING, Head Gate	1	1	1	1	1	1	1	1
19	4350029-07			GATE ASSEMBLY, Head				1	1			
20	4350029-08			GATE ASSEMBLY, Head							1	
21	4210136-01			POST, Dummy Head				1	1	1		
22	4040437-05			HEAD UNIT, Record, 2 track		1	1					
23	4040437-06			HEAD UNIT, Playback		1	1		1	1		
24	4040438-67			HEAD STACK ASSEMBLY, Record Full Track	1							
25	4040438-68			HEAD STACK ASSEMBLY, Playback, full track	1			1				
26	4040829-02			HEAD STACK ASSEMBLY, Erase, single channel, 1/4"	1							
27	4040831-02			HEAD STACK ASSEMBLY, Erase, 2 channel, 1/4"		1	1					
28	4350068-01			HEAD STACK ASSEMBLY, 1/4 Track Stereo, playback			1			1	1	
29	4350025-01			SHIM, Erase Head, .010 thick	A/R	A/R	A/R					A/R
30	4350025-02			SHIM, Erase Head, .002 thick	A/R	A/R	A/R					A/R
31	4350025-03			SHIM, Erase Head, .003 thick	A/R	A/R	A/R					A/R
32	4350025-04			SHIM, Erase Head, .005 thick	A/R	A/R	A/R					A/R
33	4210193-30			TAPE GUIDE				1	1			
38	4350017-03			BASE, Head Mounting	1	1	1	1	1	1	1	1
49	4270167-30			SPRING, Head			2			2	4	
55	4350068-02			HEAD STACK ASSEMBLY, 1/4 Track, record							1	
56	4350117-01			HEAD STACK ASSEMBLY, 1/4 Track, erase							1	

4020272P

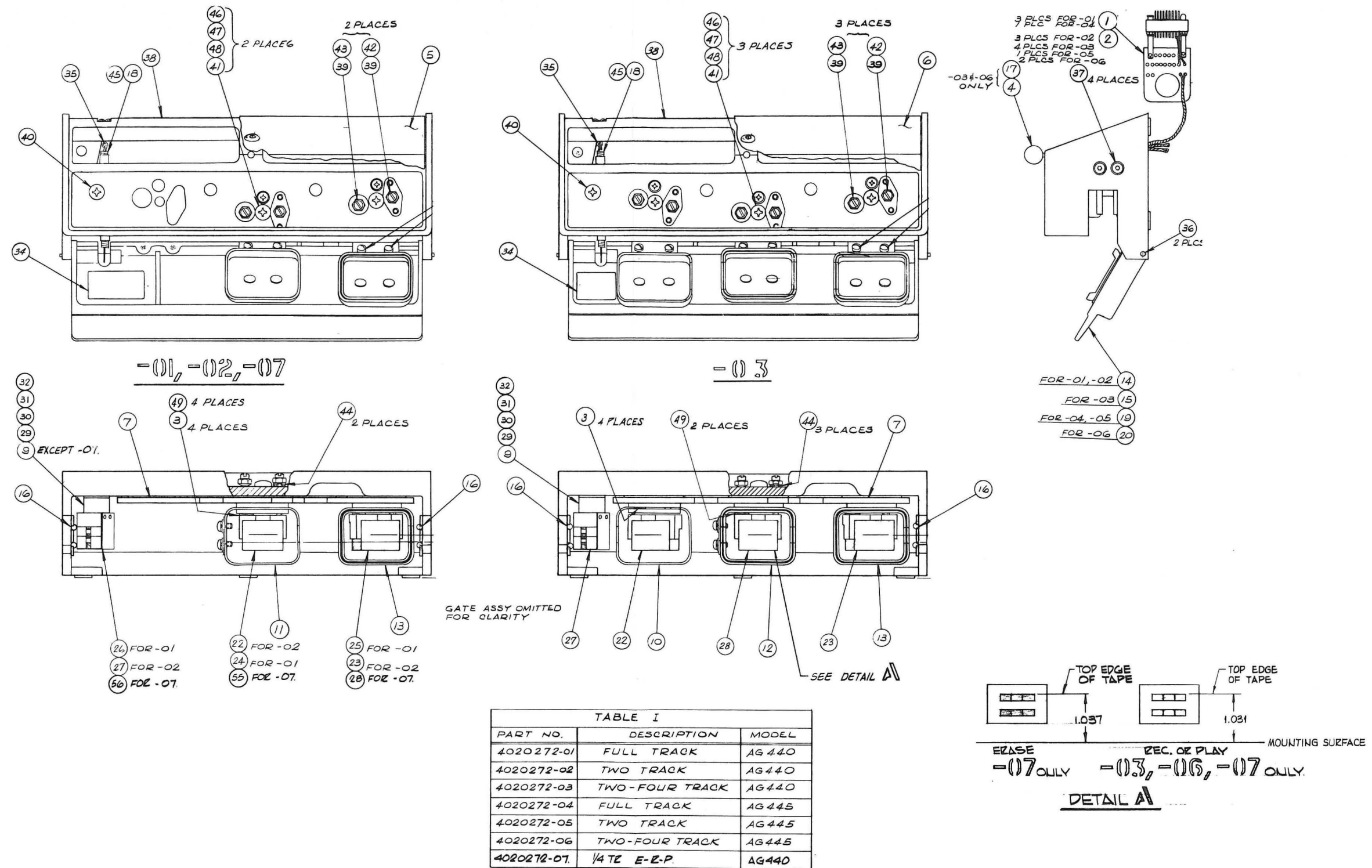
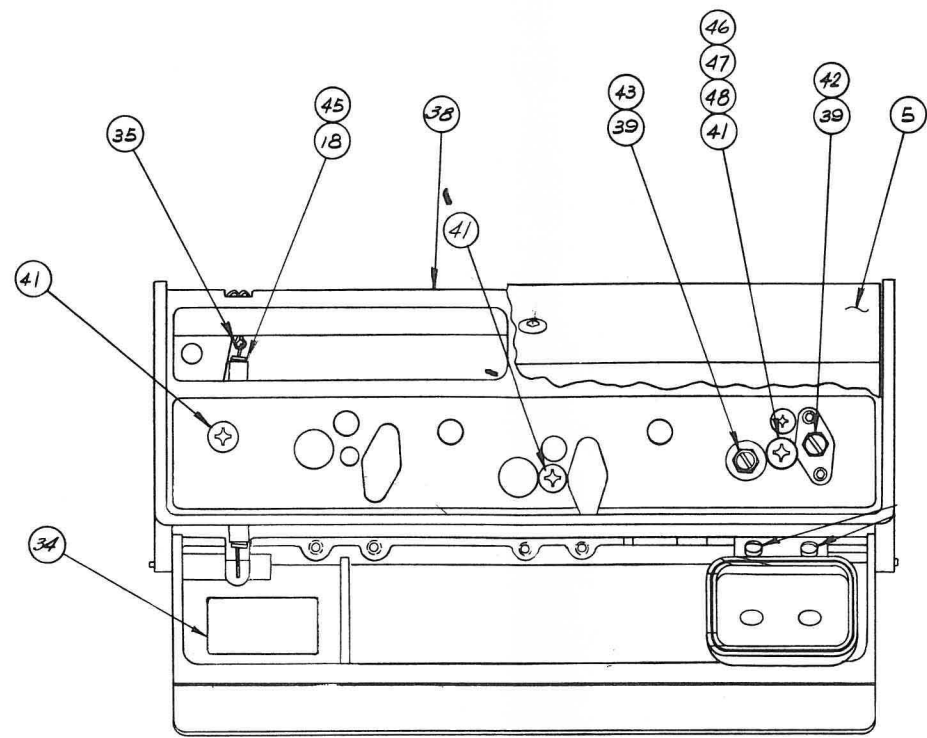
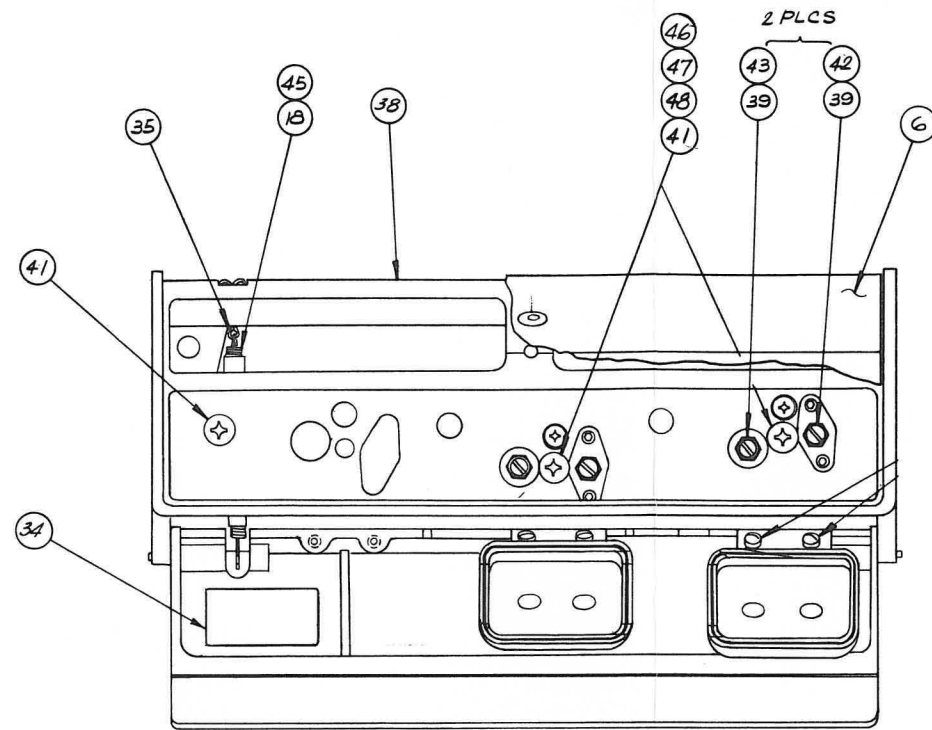

Fig. 6-1. Head Assembly, Record/Reproduce, 1/4-inch Tape



- (04 AND -05



- (06

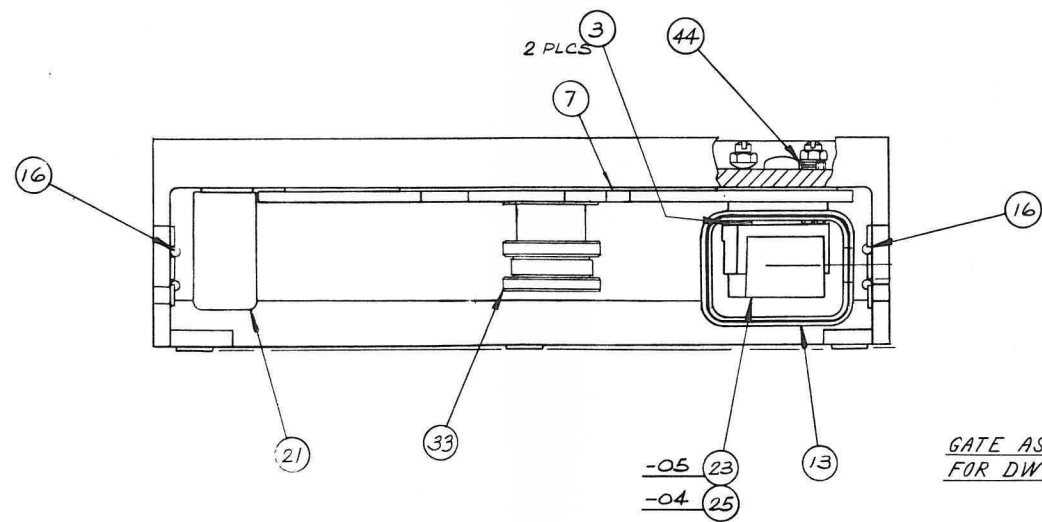

GATE ASSY OMITTED
FOR DWG CLARITY

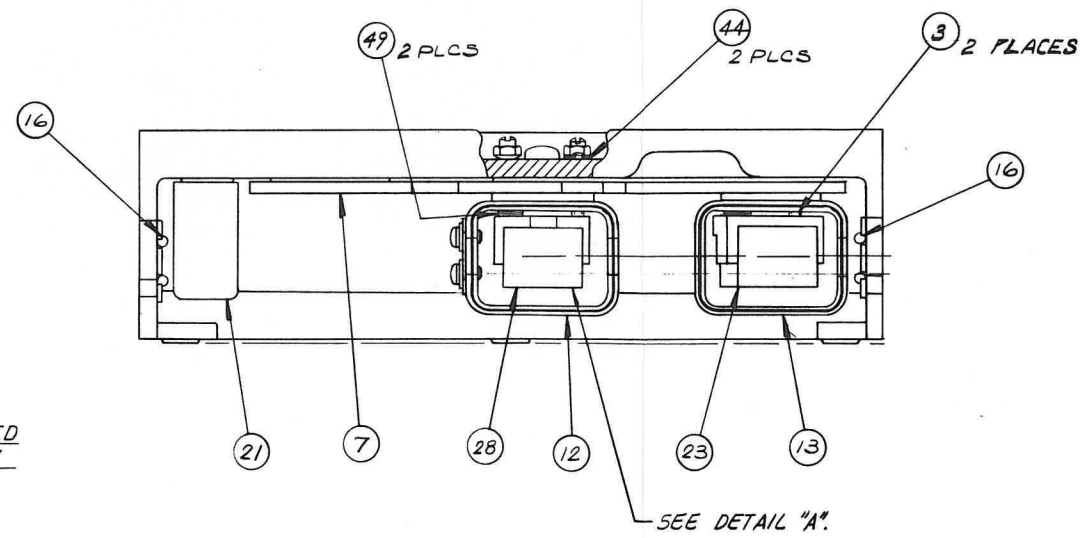

SEE DETAIL "A".

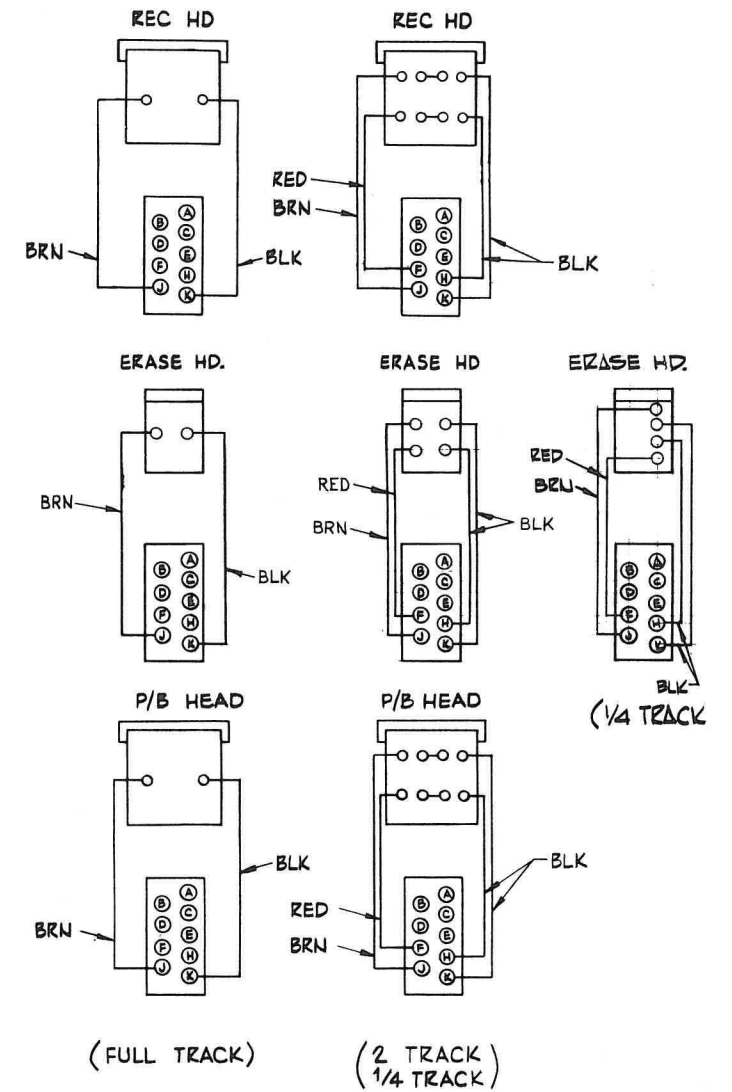

(FULL TRACK) (2 TRACK)
(1/4 TRACK)

WIRING DIAGRAM

Fig. 6-2. Head Assembly, Reproduce-only, 1/4-inch Tape

HEAD ASSEMBLY 1/2-INCH TAPE

. 4020273

(Revision N)

Ref.	-04 -05	Description	Ampex Part No.
1	3	Head Connector Assembly	4050446-04
2	4	Spring, head adjuts	4270167-10
1	1	Overlay Assembly Head Housing	4350038-01
1	1	Base, head mounting	4350017-03
1	1	Spacer, erase head	4350019-20
1	1	Shield Can Assembly, record position #3	4350022-02
1	1	Shield Can Assembly, pushbutton position #4	4350024-02
1	1	Gate Assembly Head	4350029-09
1	1	Tape Guide Assembly, left hand	4350033-01
1	1	Tape Guide Assembly, right hand	4350033-02
1	1	Spring, extension head gate	4350035-01
1	1	Gate Assembly, head	4350029-10
1	1	Post, dummy head	4210136-01
1	1	Erase Head Assembly, 1/2", 4 track	1231888-03
1	1	Head Stack Assembly, 4 channel, rec., 4 track	4040558-06
1	1	Head Stack Assembly, 4 channel, pushbutton 4 track	4040558-05
	a/r	Shim, erase head, .010 thick	4350025-01
	a/r	Shim, erase head, .002 thick	4350025-02
	a/r	Shim, erase head, .003 thick	4350025-03
	a/r	Shim, erase head, .005 thick	4350025-04
1	1	Tape Guide	4210193-40
1	1	Pin, cotter, 1/16 diameter x 3/4 long	401-008
2	2	Pin, "drive-lok", type C 3/32 diameter	403-006
4	4	Screw, cap, hex, socket, 4-40 x 1/4	470-425
2	4	Screw, fill, head, slot, 4-40 x 5/8	471-481
3	3	Screw, pan head, cross-recessed, 10-32 x 7/16	473-098
1	2	Nut, hex, 4-40	492-008
1	2	Nut, self-locking, hex, 4-40	493-001
1	2	Washer, lock, #4	502-062
1	1	Sleeving, .186 ID, black	600-001

4020273N

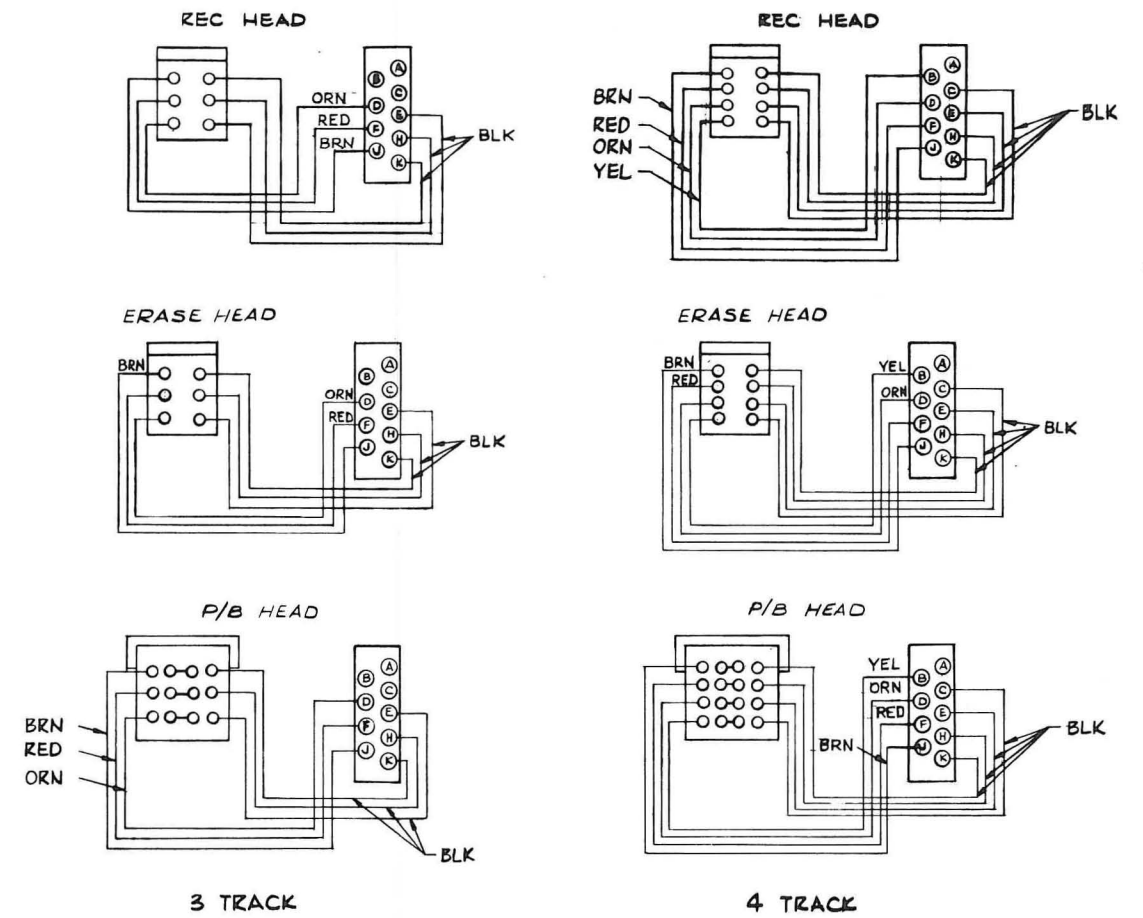
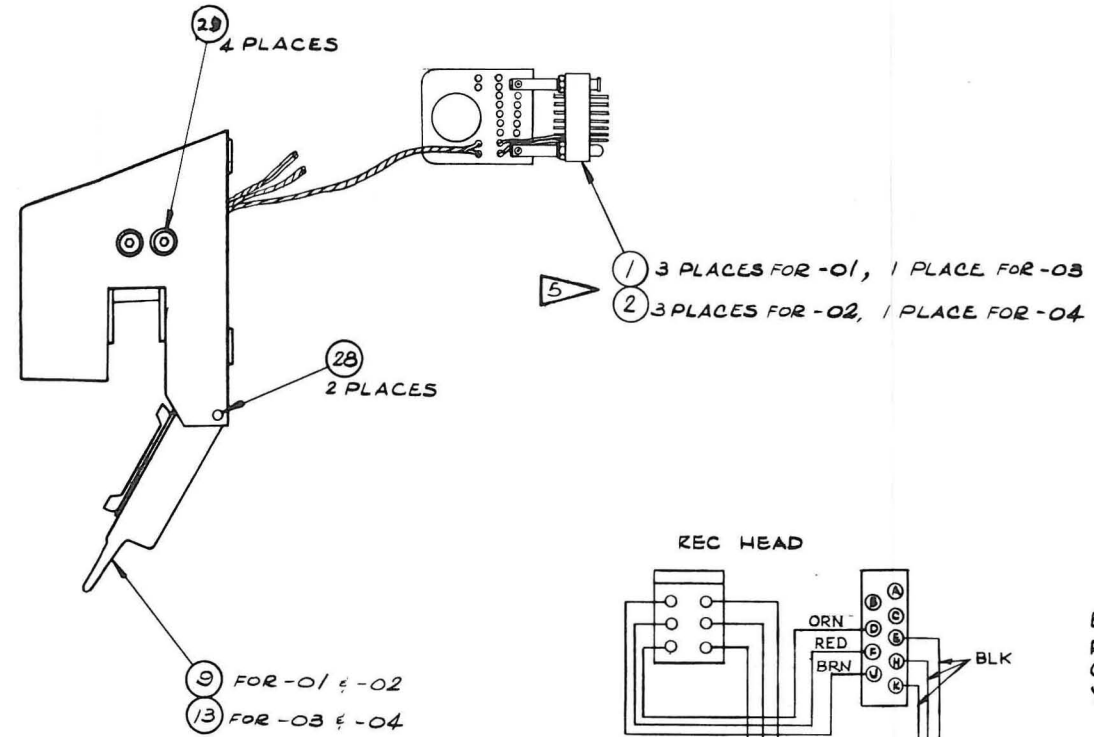
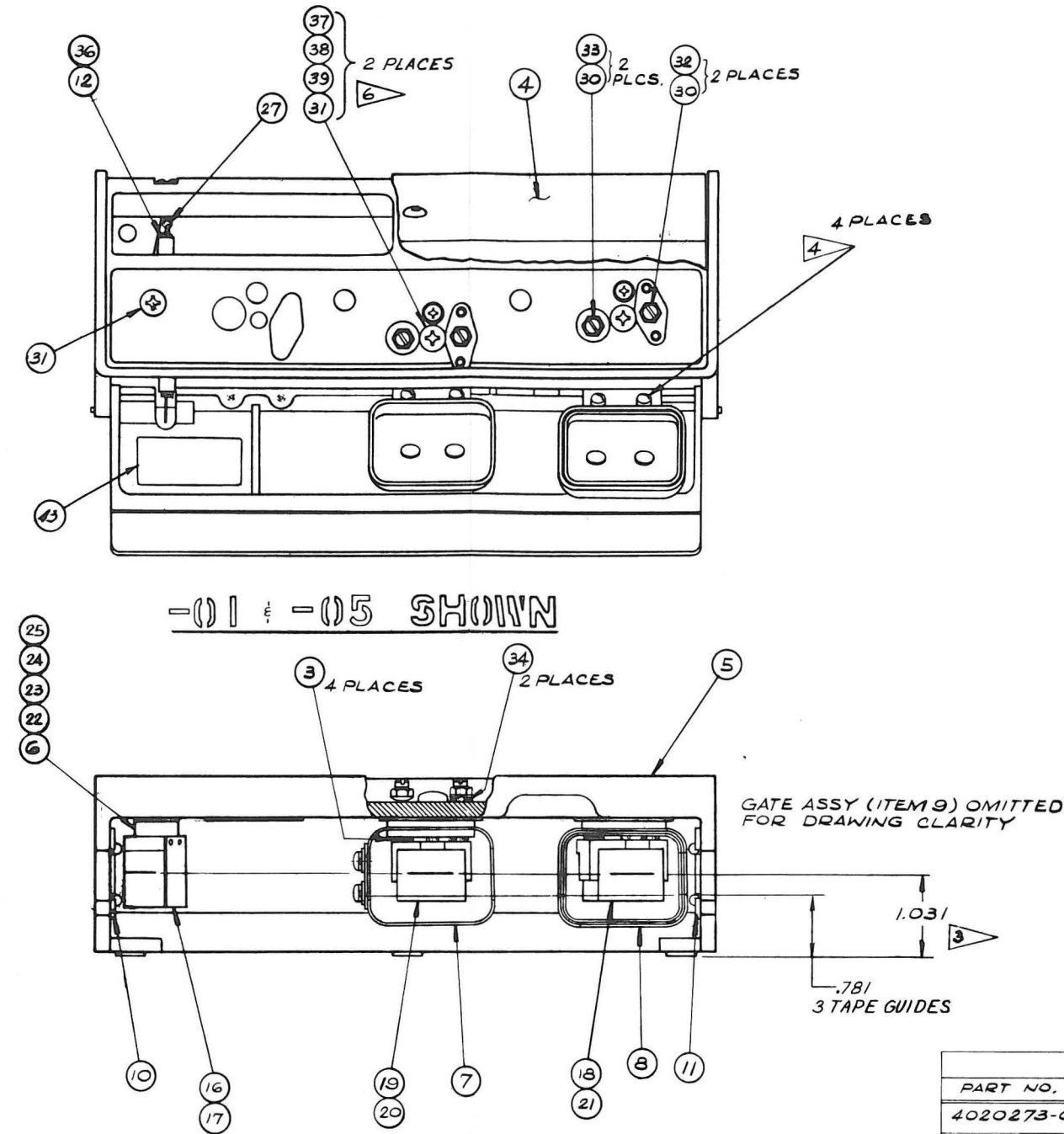

TABLE I		
PART NO.	DESCRIPTIONS	MODEL
4020273-01	3 TRACK HEAD	AG-440
4020273-02		
4020273-03	3 TRACK HEAD	AG-445
4020273-04	4 TRACK HEAD	AG-445
4020273-05	4 TRACK HEAD	AG-440

NOTES:

1. PART NO. TO BE ASSY 4020273-XX.
2. THE GAP BETWEEN THE TOP OF THE HEAD GATE AND THE FRONT OF THE HEAD HOUSING SHOULD NOT EXCEED .031.
3. CENTER LINE BETWEEN TRACKS SHALL BE ADJUSTED TO 1.031 FROM BOTTOM OF BASE HEAD MTG. PADS.
4. ADJUST SHIELD COVERS TO LINE UP FLUSH WITH SHIELD CANS.
5. ALL LEAD PAIRS FROM HEADS TO CONNECTORS TO BE TWISTED e.g. (J.K.) (F,H) etc.
6. SHIM ITEM 31 AS REQ'D. SO THAT SCREW IS FLUSH TO .010 MAX PROTRUSION INTO CAN.

WIRING DIAGRAM

Fig. 6-3. Head Assembly, Record/Reproduce, 1/2-Inch Tape

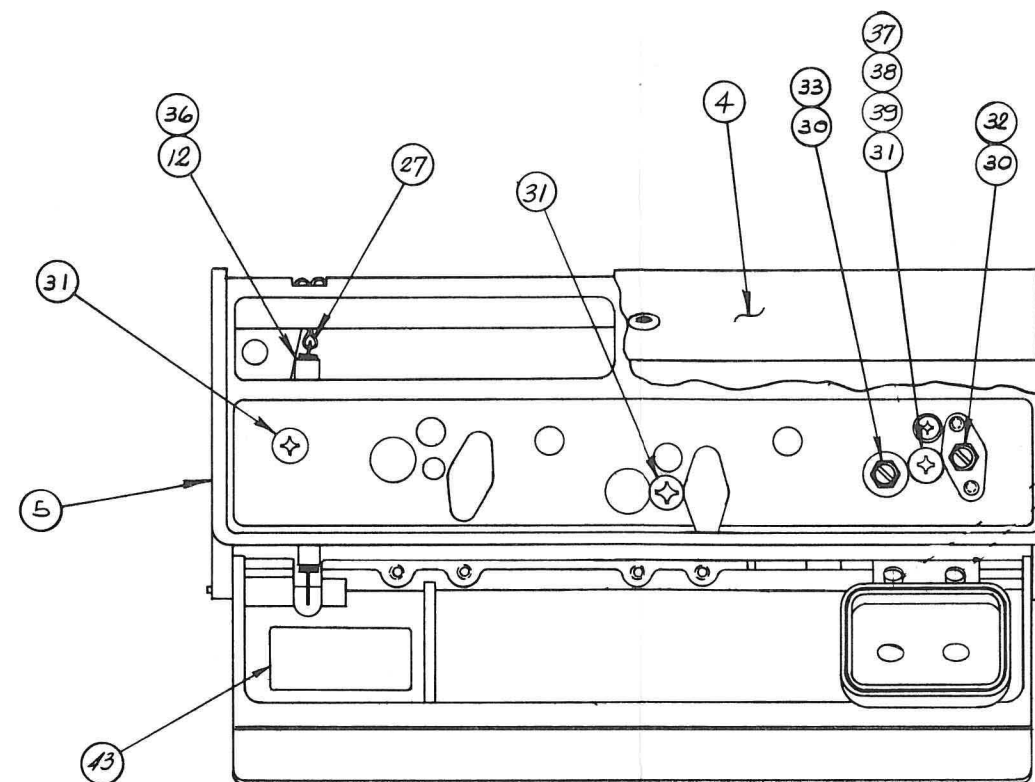

-03 & -04 SHOWN

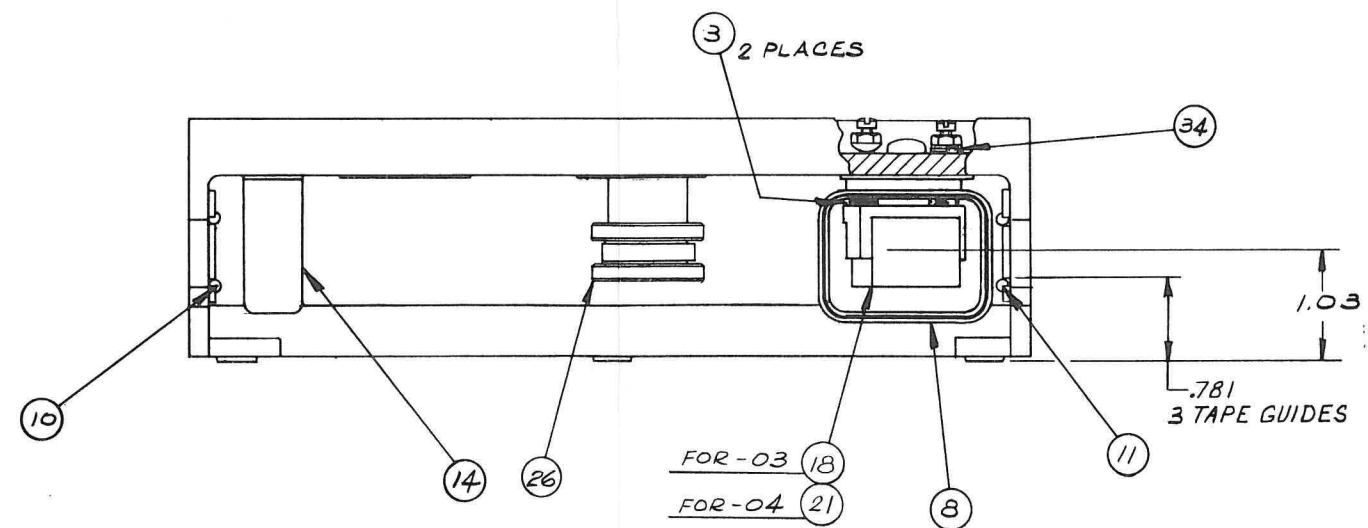

GATE ASSY (ITEM 13) OMITTED FOR DWG. CLARITY.

Fig. 6-4. Head Assembly, Reproduce-Only, 1/2-Inch Tape

HEAD CONNECTOR ASSEMBLY
 CATALOG NO. 4050446C
 (See Fig. 6-5)

4890301

ITEM	-01	-02	-03	-04	DESCRIPTION	Ampex Part No.
	X				Head Connector, assembly, 1 track head	4050446-01
		X			Head Connector, assembly, 2 track head	4050446-02
			X		Head Connector, assembly, 3 track head	4050446-03
				X	Head Connector, assembly, 4 track head	4050446-04
1	2	2	2	2	Standoff, head connector	4220243-01
2	1	1	1	1	Handle, head connector	4350031-02
3	1	1	1	1	Connector, male, rect., 9 pin	143-300
4	2	2	2	2	Rollpin, .062 dia. x .187 lg.	406-272

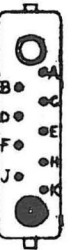
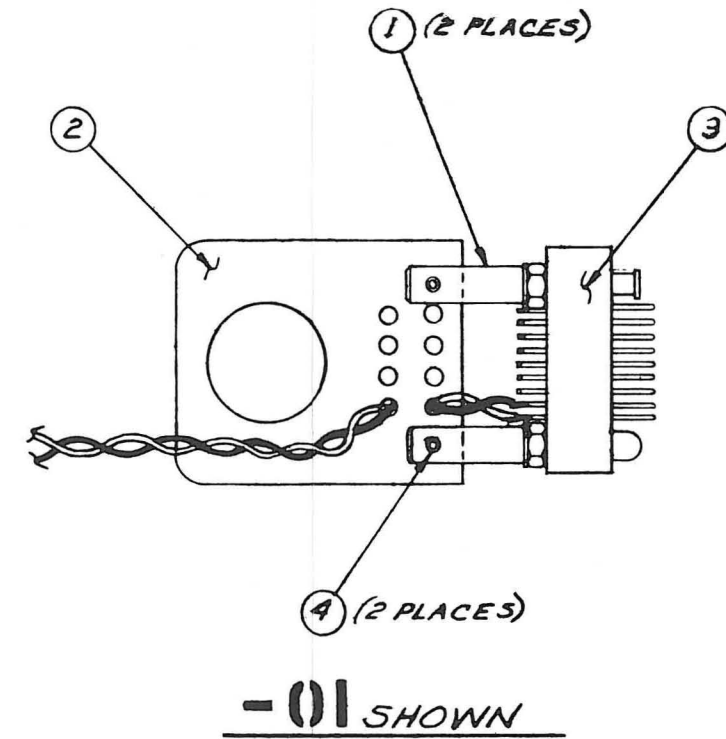

ASSY NO.	TERMINAL LETTER									
	A	B	C	D	E	F	H	J	K	
4050446-01	-	-	-	-	-	-	-	BRN	BLK	
4050446-02	-	-	-	-	-	RED	BLK	BRN	BLK	
4050446-03	-	-	-	ORN	BLK	RED	BLK	BRN	BLK	
4050446-04	-	YEL	BLK	ORN	BLK	RED	BLK	BRN	BLK	
4050446-05	-	YEL	BLK	ORN	BLK	RED	BLK	BRN	BLK	

HEAD CABLE BOX ASSEMBLY
 CATALOG NO. 4050447F
 (See Fig. 6-6)

ITEM	-06	-07	-08	-09	-10	DESCRIPTION	Ampex Part No.
	X					Head Cable Box, assembly, 1 channel, 3 position	4050447-06
		X				Head Cable Box, assembly, 2 channel, 3 position	4050447-07
			X			Head Cable Box, assembly, 3 channel, 3 position	4050447-08
				X		Head Cable Box, assembly, 4 channel, 3 position	4050447-09
					X	Head Cable Box, assembly, 2 channel, 4 position	4050447-10
1	1	1	1	1	1	Bracket, head cable mounting	4040947-02
2	5	5	10	10	5	Clamp, assembly, cable	4040951-01
3	1	1	1	1	1	Clamp, assembly, playback cable	4040952-01
4	1	2	3	4	2	Head Cable, assembly, erase	4050143-60
5	1	2	3	4	2	Head Cable, assembly, record	4050144-70
6	1	2	3	4	2	Head Cable, assembly, reproduce	4050445-01
7					1	Rod, switch	4350034-01
8	1	1	1	1	1	Cover, head cable bracket	4290644-01
10					1	Wire, retaining	4320115-10
11					1	Switch, slide	4620124-20
12	4	4	4	4	4	Connector, receptacle, female, 9 socket	143-301
13	3	3	3	3	3	Marker Strip, No. 1	202-006
14		3	3	3	3	Marker Strip, No. 2	202-007
15			3	3		Marker Strip, No. 3	202-008
16				3		Marker Strip, No. 4	202-009
27					1	Terminal Strip, A1, A1, D	180-983
28	1	1	1	1	1	Bracket, head switch	4260110-01
29					1	Shield, head switch	4600055-01
Items of standard hardware, wire, etc., not listed							

HEAD CABLE BOX
 CATALOG NO. 4050448D

ITEM	-06	-07	-08	-09	-10	DESCRIPTION	Ampex Part No.
	X					Head Cable Box Assembly, 1 channel, reproduce-only	4050448-06
		X				Head Cable Box Assembly, 2 channel, 2 position, reproduce-only	4050448-07
			X			Head Cable Box Assembly, 3 channel, reproduce-only	4050448-08
				X		Head Cable Box Assembly, 4 channel, reproduce-only	4050448-09
					X	Head Cable Box Assembly, 2 channel, reproduce-only	4050448-10
1	1	1	1	1	1	Bracket, head cable mounting	4040947-02
2	1	1	2	2	1	Clamp Assembly, cable	4040951-01
3	1	1	1	1	1	Clamp Assembly, reproduce cable	4040952-01
6	1	2	3	4	2	Head Cable Assembly, reproduce	4050445-01
7		1				Rod, Switch	4350034-01
8	1	1	1	1	1	Cover, head cable bracket	4290644-01
10		1				Wire, retaining	4320115-10
11		1				Switch, slide	4620124-20
12	2	2	2	2	2	Connector, receptacle, female, 9 socket	143-301
13	1	1	1	1	1	Marker Strip, No. 1	202-006
14		1	1	1	1	Marker Strip, No. 2	202-007
15			1	1		Marker Strip, No. 3	202-008
16				1		Marker Strip, No. 4	202-009
27		1				Terminal Strip, A1, A1, D	180-983
28	1	1	1	1	1	Bracket, head switch	4260110-01
29		1				Shield, head switch	4600055-01

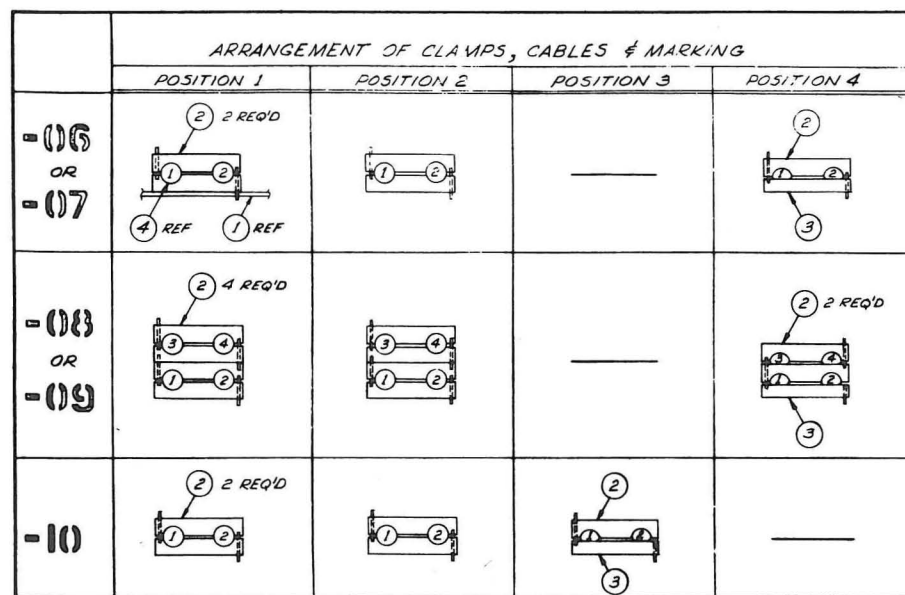

CONN A			
ITEM NO.	MARKER NO.	WIRE COLOR	PIN LETTER
④ (ERASE)	1	WHT	J
		BLK	K
	2	WHT	F
		BLK	H
3	WHT	D	
	BLK	E	
4	WHT	B	
	BLK	C	

CONN D			
ITEM NO.	MARKER NO.	WIRE COLOR	PIN LETTER
⑥ (REP)	1	RED	J
		BLK	K
	2	RED	F
		BLK	H
3	RED	D	
	BLK	E	
4	RED	B	
	BLK	C	

CONN B			
ITEM NO.	MARKER NO.	WIRE COLOR	PIN LETTER
⑤ (REC)	1	WHT	J
		BLK	K
	2	WHT	F
		BLK	H
3	WHT	D	
	BLK	E	
4	WHT	B	
	BLK	C	

-10 ONLY
FOR HOOKUP TO
CONNECTORS C & D,
SEE SCHEMATIC

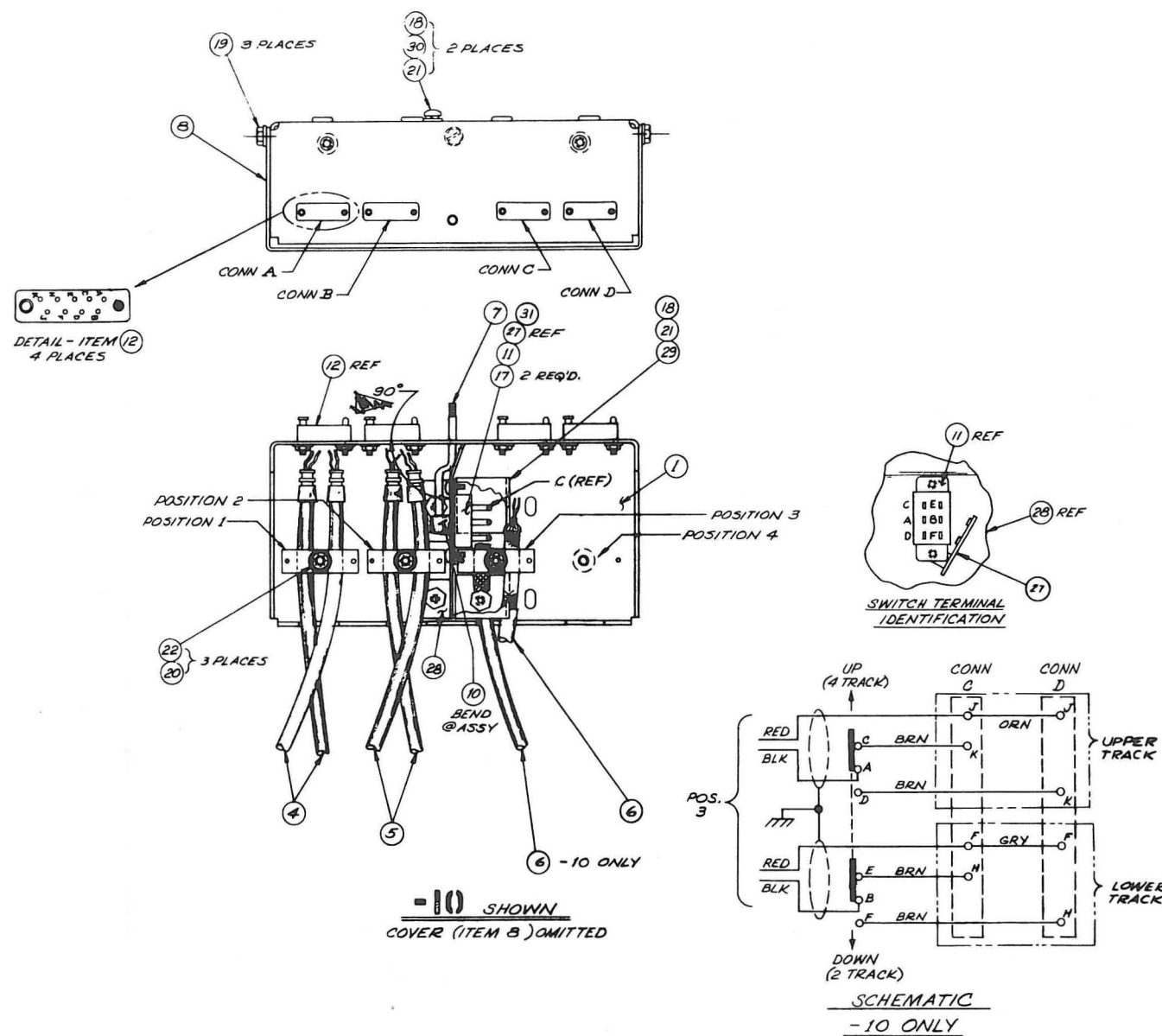

Fig. 6-6 . Head Cable Box Assembly

SECTION VI

TRANSPORT

TRANSPORT

SCRAPE FLUTTER IDLER ASSEMBLY

4040955 (Rev. C)

Item	-01	-02	Description	Ampex Part No.
1	2	2	Holder Assembly	4040953-01
2	1		Idler, Scrape Flutter	4250207-01
3		1	Idler, Scrape Flutter	4250207-02
4	1	1	Yoke	4230239-02
6	2	2	Screw, Set, cup point, 2-56 x 1/8	477-215

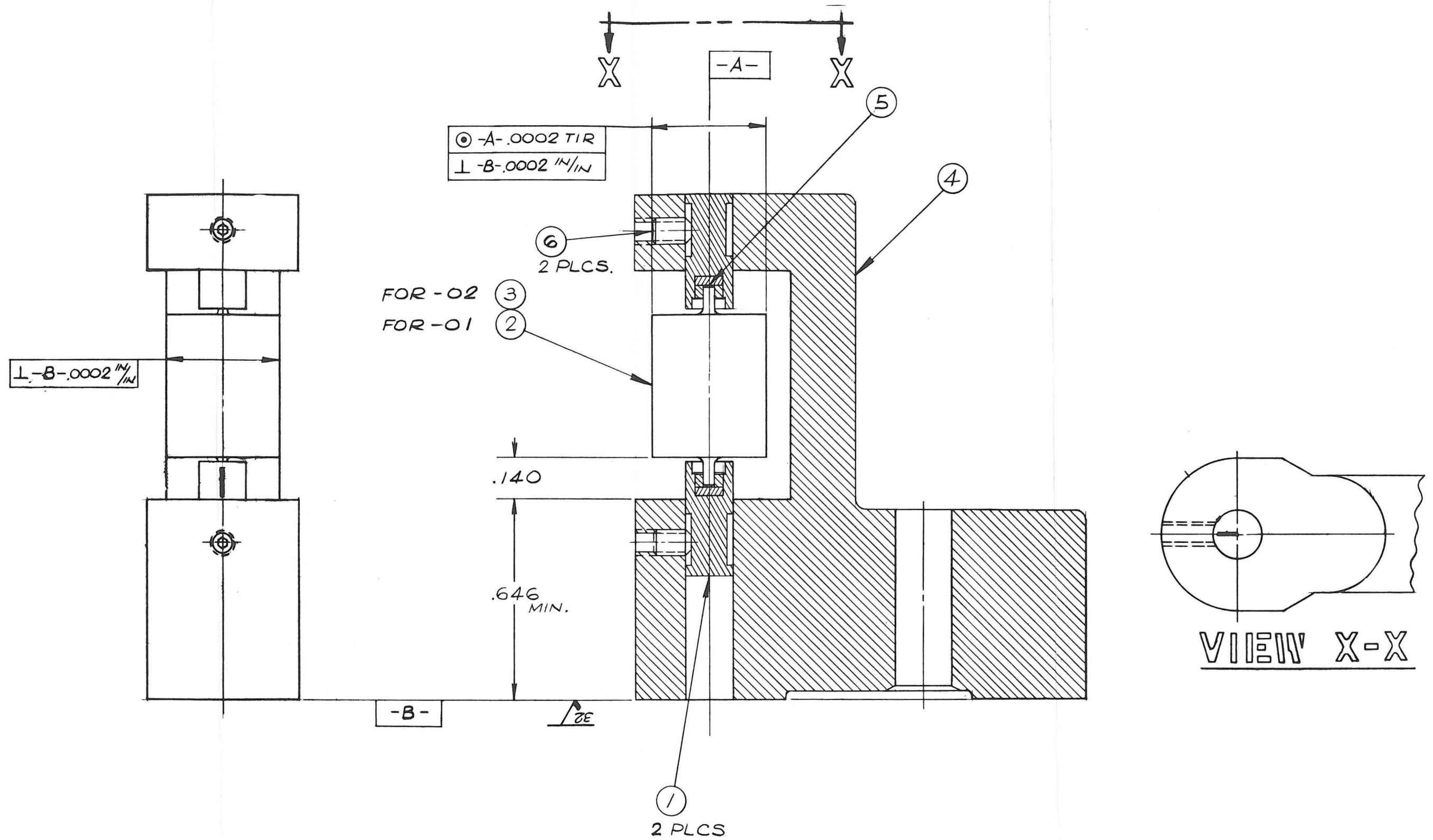

Fig. 6-7. Scrape Flutter Idler Assembly

TAPE TRANSPORT ASSEMBLY

4020271

(Revision AF)

(See Figs. 6-8 and 6-9)

(Electronic component designation list is given with Fig. 6-20)

ITEM	-13	-14	-15	-16	Description *	Ampex Part No.
	X				Tape Transport, assembly, 7-1/2 and 15 ips, 60 Hz	4020271-13
		X			Tape Transport, assembly, 7-1/2 and 15 ips, 50 Hz	4020271-14
			X		Tape Transport, assembly 3-3/4 and 7-1/2 ips, 60 Hz	4020271-15
				X	Tape Transport, assembly, 3-3/4 and 7-1/2 ips, 50 Hz	4020271-16
1	1	1	1	1	Oil Kit, motor	4010825-02
5	1	1	1	1	Control Box, assembly (see Figs. 6-17, 6-18)	4020293-07
6	1	1	1	1	Tape Lifter, assembly (see Fig. 6-11)	4030259-03
7	1	1	1	1	Takeup, assembly (see Fig. 6-12)	4030297-01, -02, -03
8	1	1	1	1	Rewind, assembly (see Fig. 6-13)	4030298-01, -02, -03
9	1	1	1	1	Solenoid, assembly, capstan	4030272-02
	1	1	1	1	Stop, solenoid	4220139-20
	1	1	1	1	Spring, solenoid return	4270161-10
	1	1	1	1	Spring, capstan idler adjustment	4270162-10
	1	1	1	1	Shield, solenoid	4290642-01
	1	1	1	1	Bolt, eye	4400604-20
	1	1	1	1	Solenoid	4590022-01
	2	2	2	2	Solderless connectors	171-008
	1	1	1	1	Washer, felt	503-015
10	1	1	1	1	Solenoid, assembly, tape lifter	4030273-02
	1	1	1	1	Link	4230242-01
	1	1	1	1	Stop, solenoid	4260184-10
	1	1	1	1	Solenoid	4590118-01
	2	2	2	2	Solderless connectors	171-008
51			1	1	Dust Cap, assembly, capstan	4041143-02
50	1	1			Dust Cap, assembly, capstan	4041143-01
13	1	1	1	1	Capacitor, assembly, drive motor (C601)	4040591-02
14	1	1	1	1	Reel Idler, assembly (see Fig. 6-15)	4040970-02
15	1	1	1	1	Takeup Tension Arm, assembly 6-7.39	4040974-05
	1	1	1	1	Tape Guide	4210310-01
	1	1	1	1	Hook	4230158-20
	1	1	1	1	Cap	4250193-01
	1	1	1	1	Spring, tension	4270158-10
	1	1	1	1	Screw, tape guide and hook mounting	4400593-01
16	1	1	1	1	Top Plate, assembly (no replaceable parts)	4040990-01
17	1	1	1	1	Escutcheon, assembly, left	4040991-02
18	1				Drive Motor, assembly 7-1/2 and 15 ips, 60 Hz (see Fig. 6-18)	4040993-07
19			1		Drive Motor, assembly 3-3/4 and 7-1/2 ips, 60 Hz (see Fig. 6-16)	4040993-08
20			1		Drive Motor, assembly 7-1/2 and 15 ips, 50 Hz (see Fig. 6-16)	4040993-09
21				1	Drive Motor, assembly 3-3/4 and 7-1/2 ips, 50 Hz (see Fig. 6-16)	4040993-10
22	2	2	2	2	Capacitor, assembly, takeup and rewind motors (C617, C618)	4050361-10
23	1	1	1	1	Safety Switch, assembly	4050436-01
24	3	3	3	3	Pushbutton, white	4100182-01
25	1	1	1	1	Pushbutton, yellow	4100182-02
26	1	1	1	1	Pushbutton, red	4100182-03
27	1	1	1	1	Escutcheon, pushbutton, right	4110266-02
28	2	2	2	2	Guard reel	4110267-02
29	4	4	4	4	Pad, toggle switch	4130103-01
30	1	1	1	1	Shield, safety switch	4170184-01
34	1	1	1	1	Flywheel, reel idler	4250202-01
36	1	1	1	1	Spring, tape lifter solenoid	4270117-01
37	1	1	1	1	Shield, drive motor	4290641-01
38	1	1	1	1	Spring, tape lifter return	4270252-02
41	1	1	1	1	Plate, tape lifter solenoid mounting	4330255-01
42	2	2	2	2	Plate, motor capacitor mounting	4330256-01
43	1	1	1	1	Plate, capstan solenoid mounting	4330257-01
44	2	2	2	2	Screw, tape lifter mounting	4400594-01
45	a/r	a/r	a/r	a/r	Washer, 0.315 x .005 thick	4440113-10
46	a/r	a/r	a/r	a/r	Washer, 0.315 x .010 thick	4440113-20
47	a/r	a/r	a/r	a/r	Washer, 0.315 x .003 thick	4440113-50
48	1	1	1	1	Pushbutton, green	4100182-04
49	1	1	1	1	Washer, lamicoïd, .015 thick	4440025-30
87	1	1	1	1	Fan, 5-inch diameter	591-001
90	1	1			Capstan Idler, assembly, 7-1/2 and 15 ips	4030279-15
91			1	1	Capstan Idler, assembly, 3-3/4 and 7-1/2 ips	4030279-16
	1	1			Wheel, assembly	4040404-10
			1	1	Wheel, assembly	4040404-50
	1	1	1	1	Cap, capstan idler	4100166-10
					(No other parts replaceable)	---

4020271AF

*Non-replaceable parts, standard hardware, wire, etc., not listed

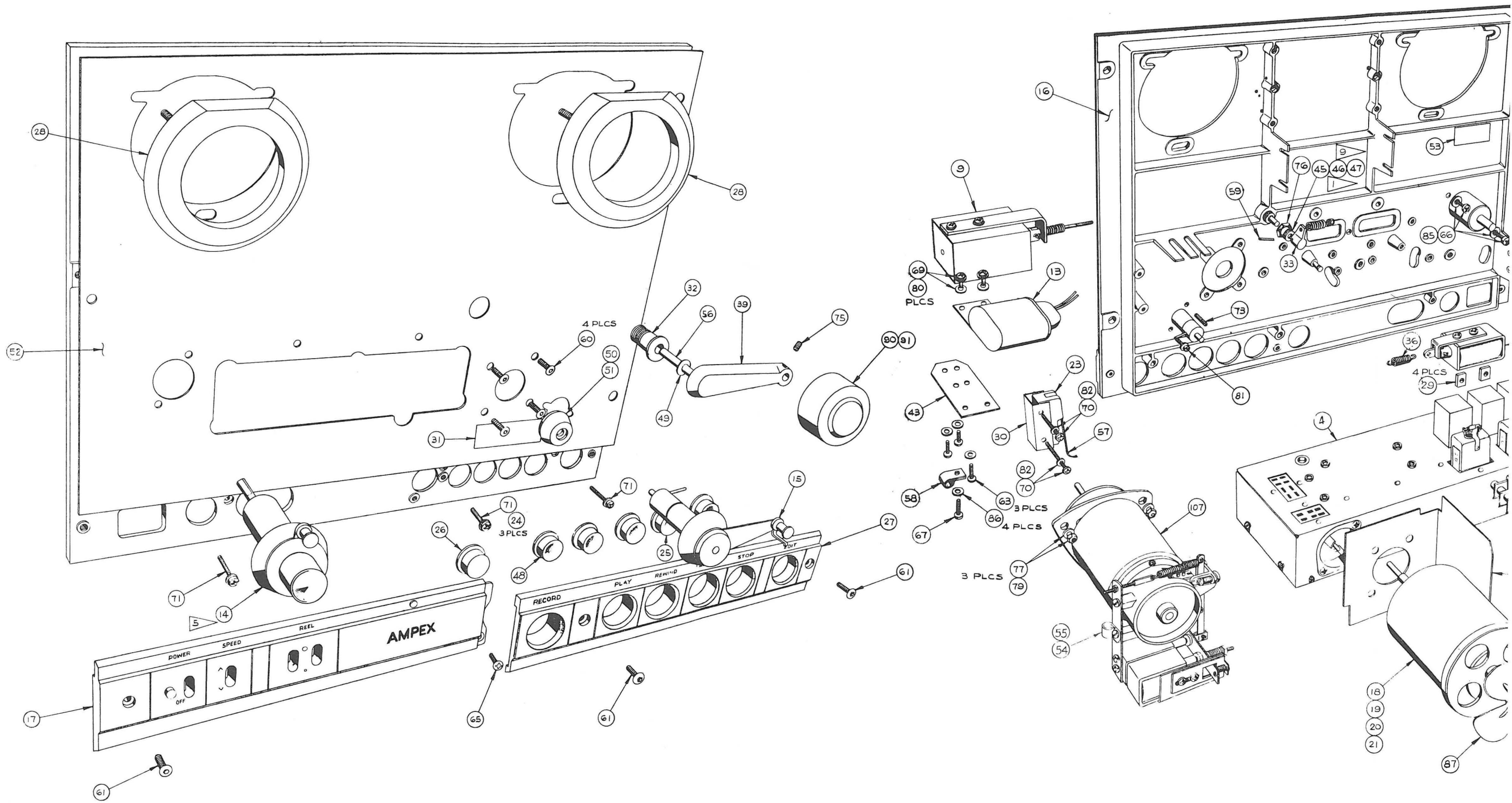
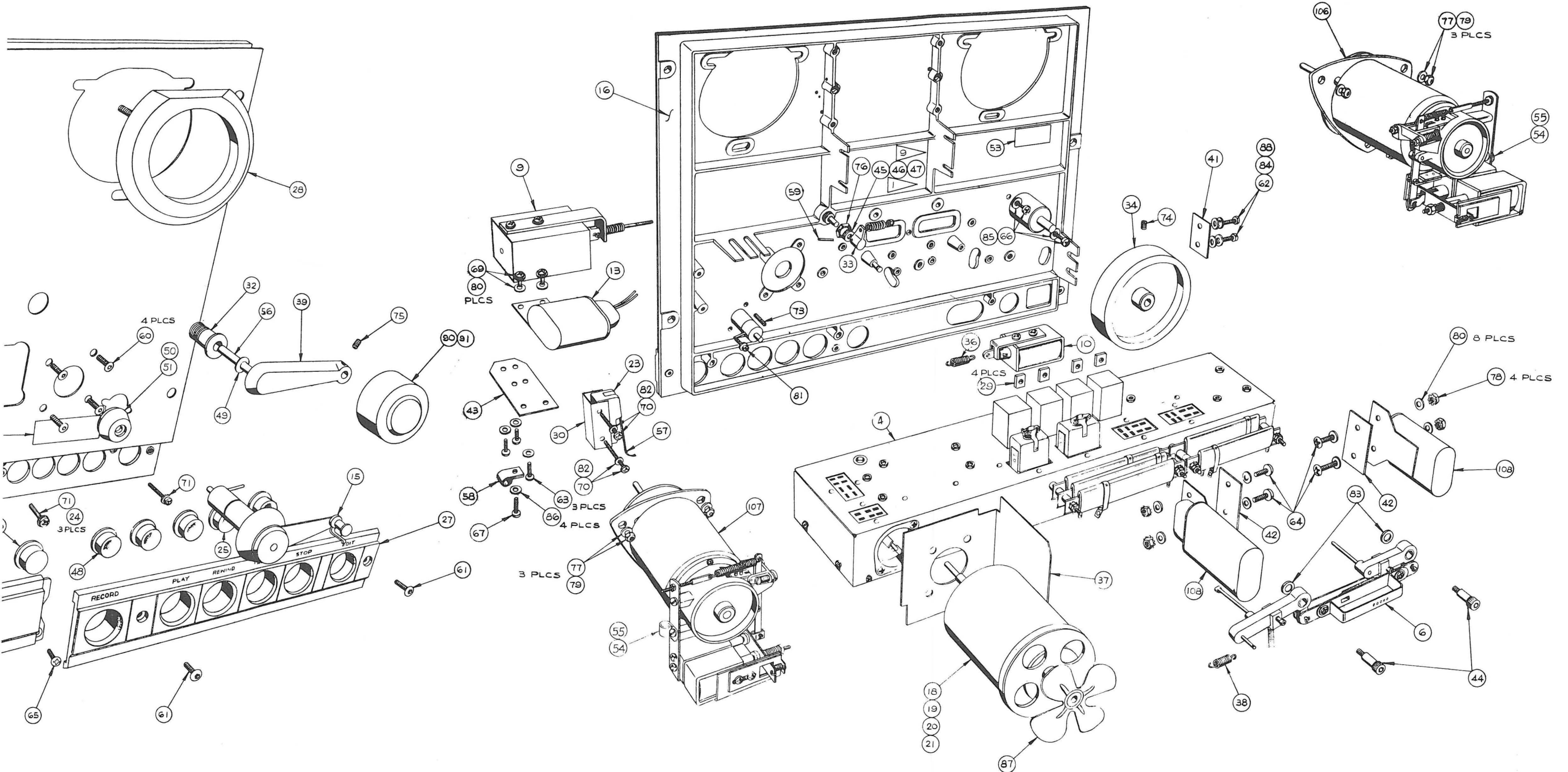
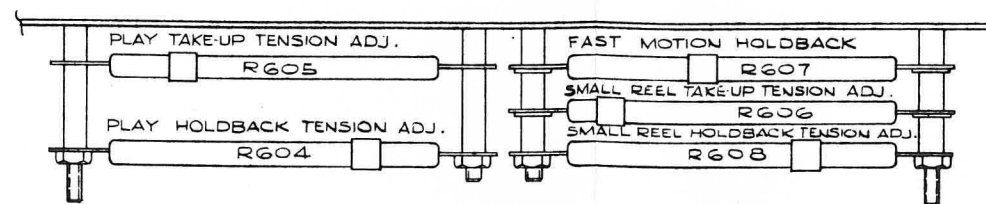

Fig. 6-8. Tape Transport Assembly, Front



8. Tape Transport Assembly, Front

Fig. 6-9. Tape Transport Assembly, Rear



TAKE-UP & SUPPLY TENSION ADJUSTMENTS

CONTROL BOX KNIFE DISCONNECT CONNECTION INFORMATION

HARNES WIRE COLOR	PART DESCRIPTION	TERM. COLOR
BRN	K609 SOLENOID, TAPE LIFTER	BLK
WHT/VIO	K609 SOLENOID, TAPE LIFTER	BLK
BLU	K610 SOLENOID, CAPSTAN	BLK
WHT/YEL	K610 SOLENOID, CAPSTAN	BLK
YEL	C601 CAPACITOR, CAPSTAN MOTOR	BRN
WHT/VIO	C601 CAPACITOR, CAPSTAN MOTOR	BRN
WHT/RED	S603 SWITCH, SAFETY	WHT/RED
VIO	S603 SWITCH, SAFETY	VIO

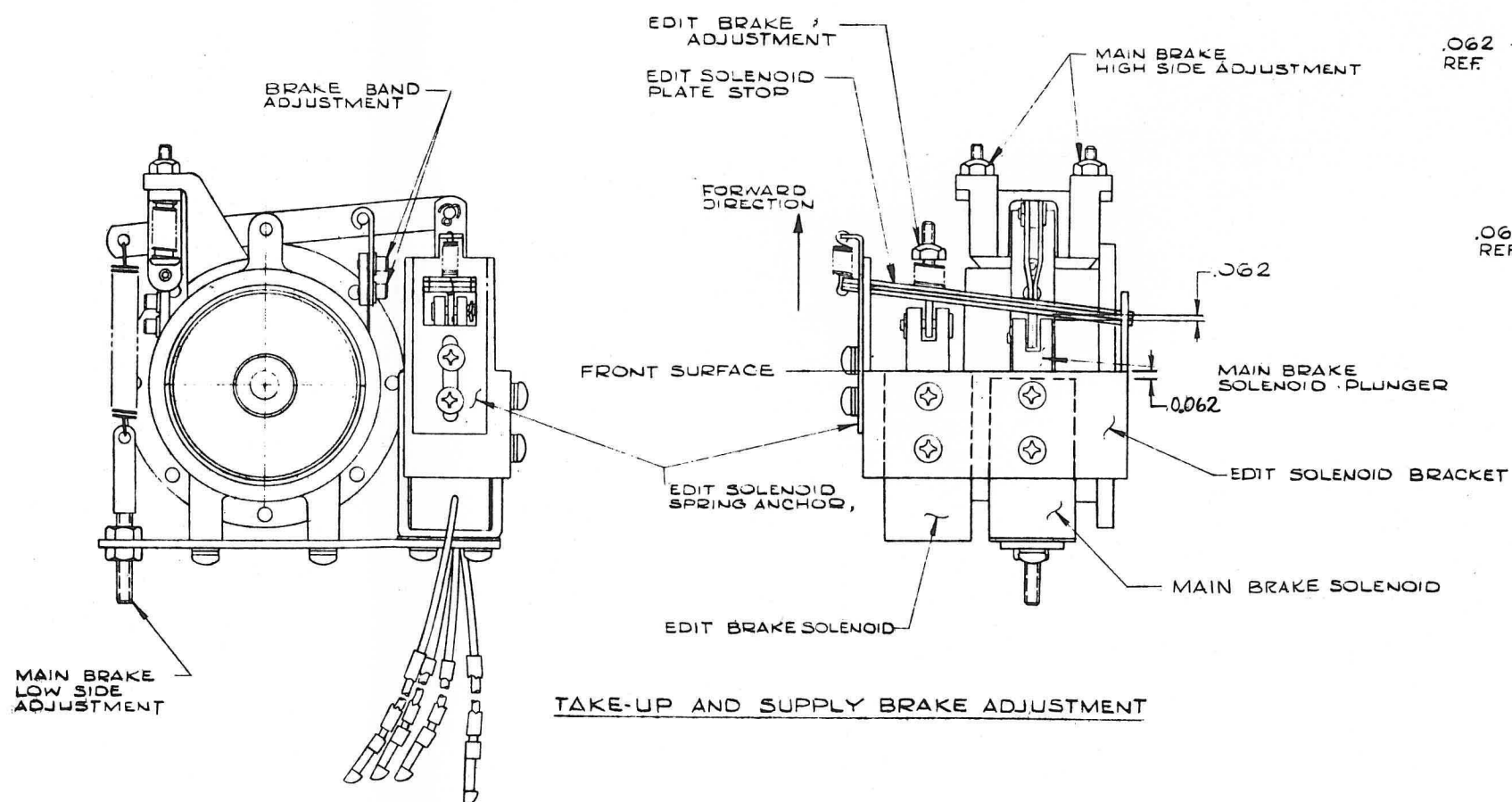

TAKE-UP AND SUPPLY BRAKE ADJUSTMENT

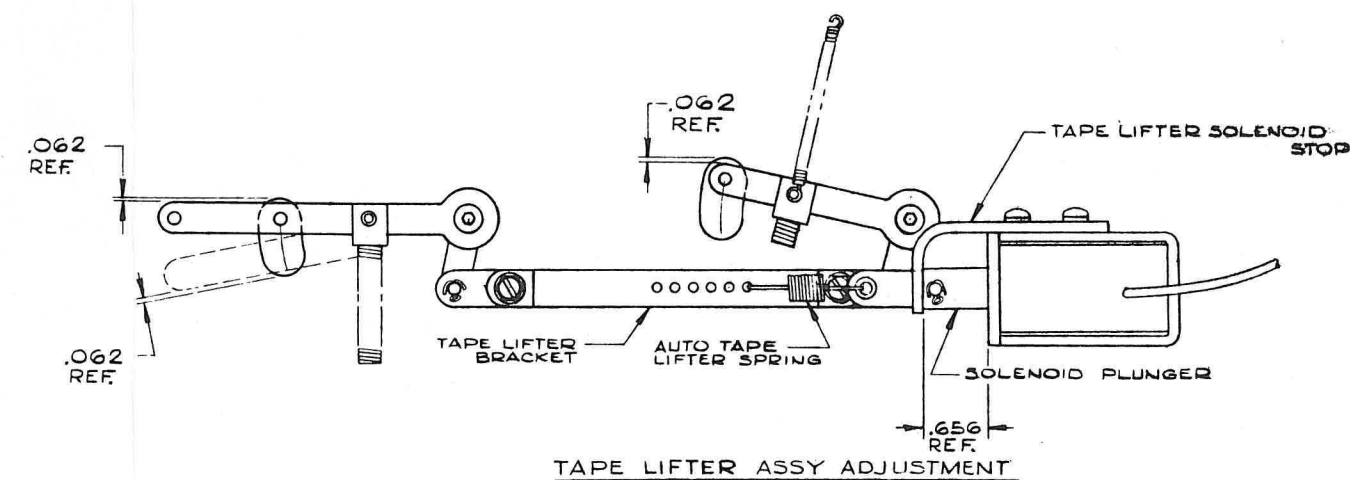

TAPE LIFTER ASSY ADJUSTMENT

Fig. 6-10. Tape Transport Adjustments

TAPE LIFTER ASSEMBLY
4030259 (Ref. E)
(See Fig. 6-11)

Item	Qty	DESCRIPTION	Ampex Part No.
		Tape lifter, assembly	4030259-03
1	1	Tape Lifter, left hand	4040965-03
2	1	Tape Lifter, right hand	4040966-03
3	2	Link	4230244-01
4	1	Bracket	4260384-01
5	1	Spring	4270254-01
6	2	Pin, Clevis, 1/8-inch dia.	400-005
12		Spring Clip	4030278-01
16		Tape, Plastic Foam, 0.063 thk x 0.187 wide	225-275
17		Tape, Polyvinyl Foam, 0.125 thk x 0.375 wide	225-298
Items of standard hardware not listed			

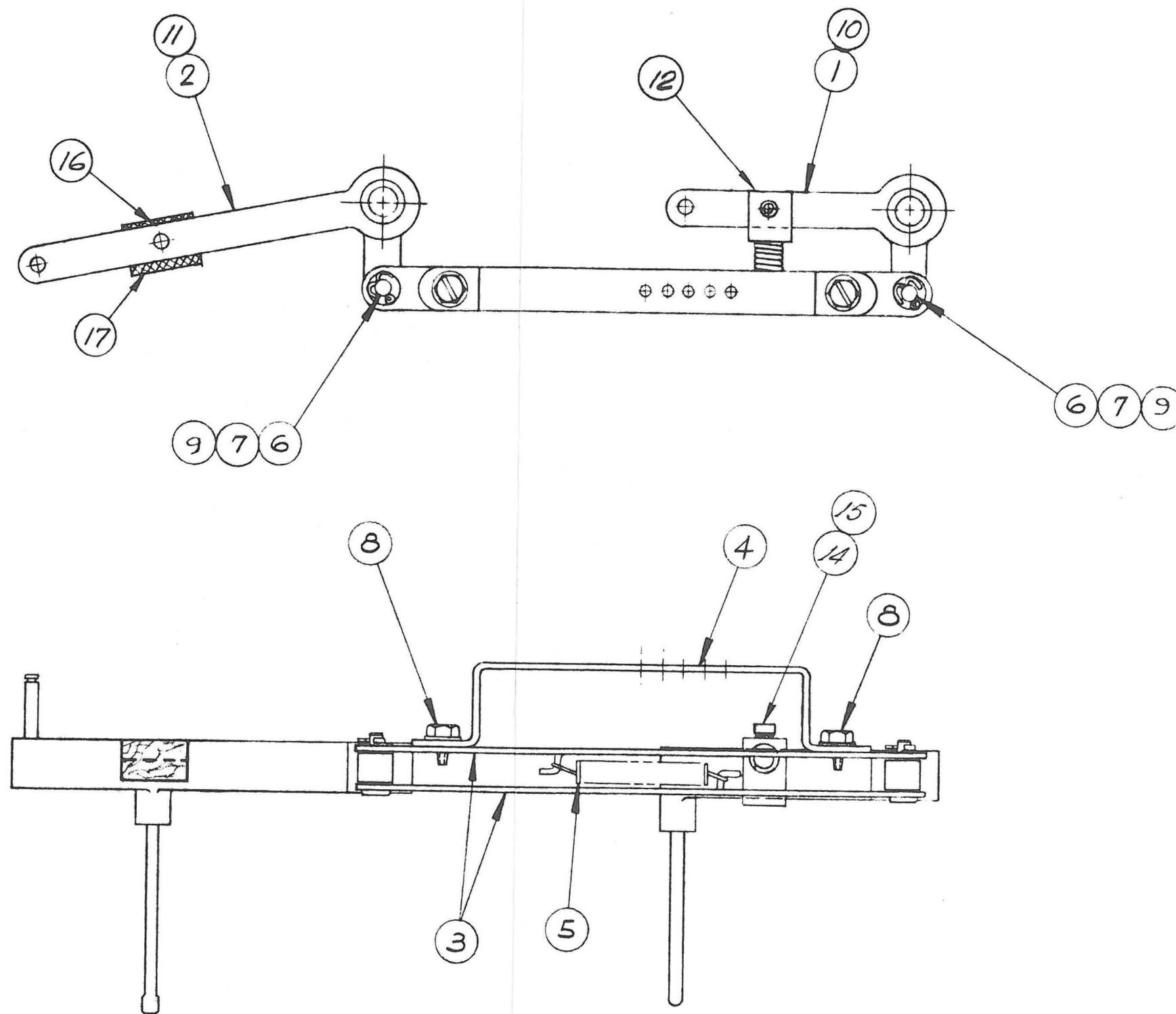

Fig. 6-11. Tape Lifter Assembly, Tape Transport

TAKEUP ASSEMBLY

4030297C
(See Fig. 6-12)

Item	-01	-02	-03	DESCRIPTION	Ampex Part No.
	X			Takeup assembly	4030297-01
		X		Takeup assembly	4030297-02
			X	Takeup assembly	4030297-03
1	1	1	1	Brake, assembly (see Fig. 6-14)	4030264-03
2	1			Motor assembly (G. E.)	4040768-02
28			1	Motor assembly (Takanawa)	4040768-08
3	1	1	1	Pad, turntable	4130163-02
4	1	1	1	Drive Plate	4320128-10
7	1	1	1	Connector, plug, 8 pins, male	145-013
8	12	12	12	Solderless Connector	171-008
27		1		Motor Assembly (Ashland)	4040768-04
Items of standard hardware, wire, etc., not listed					

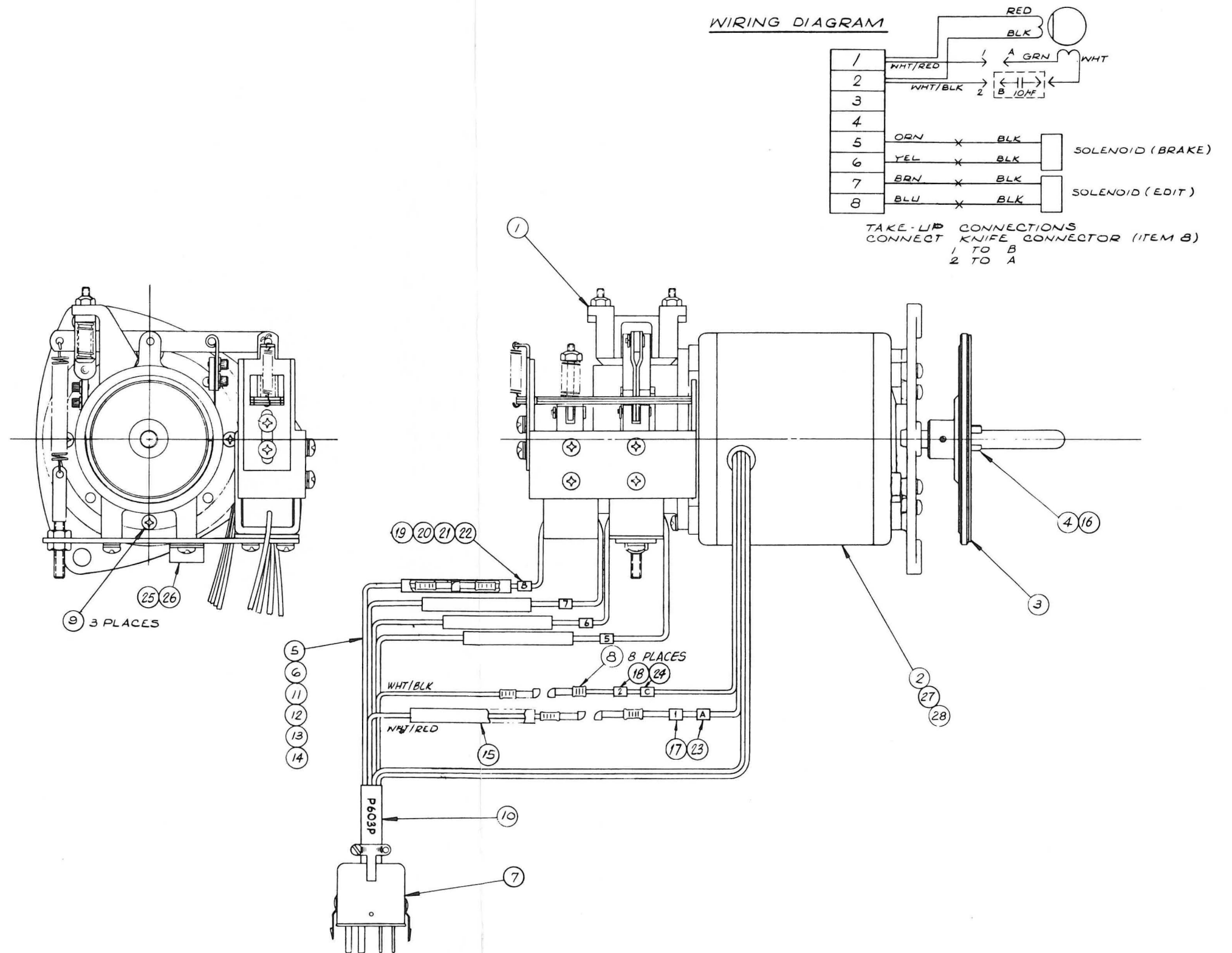

Fig. 6-12. Take-up Assembly

REWIND ASSEMBLY
4030298 C
(See Fig. 6-13)

Item	-01	-02	-03	DESCRIPTION	Ampex Part No.
	X			Rewind assembly	4030298-01
		X		Rewind assembly	4030298-02
			X	Rewind assembly	4030298-03
1	1	1	1	Brake assembly (see Fig. 6-14)	4030264-04
2	1			Motor assembly (G.E.)	4040768-01
29			1	Motor assembly (Takanawa)	4040768-07
3	1	1	1	Pad, turntable	4130163-02
4	1	1	1	Drive Plate	4320128-10
7	1	1	1	Connector, plug, 8 pins, male	145-013
8	12	12	12	Solderless connectors	171-008
28		1		Motor Assembly (Ashland)	4040768-03
Items of standard hardware, wire, etc., not listed					

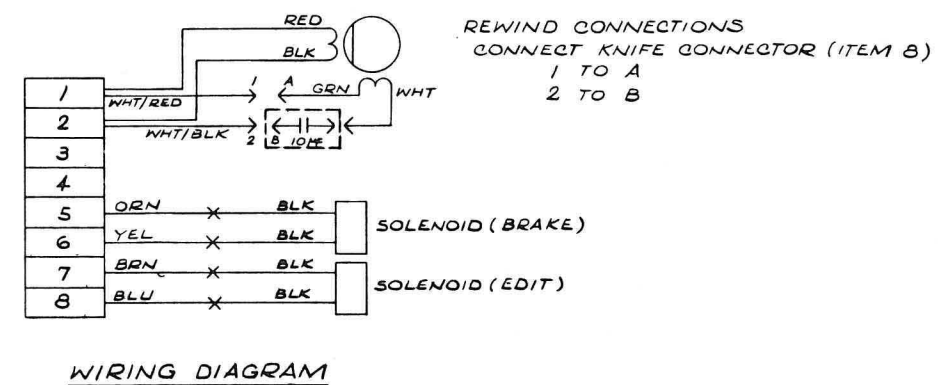
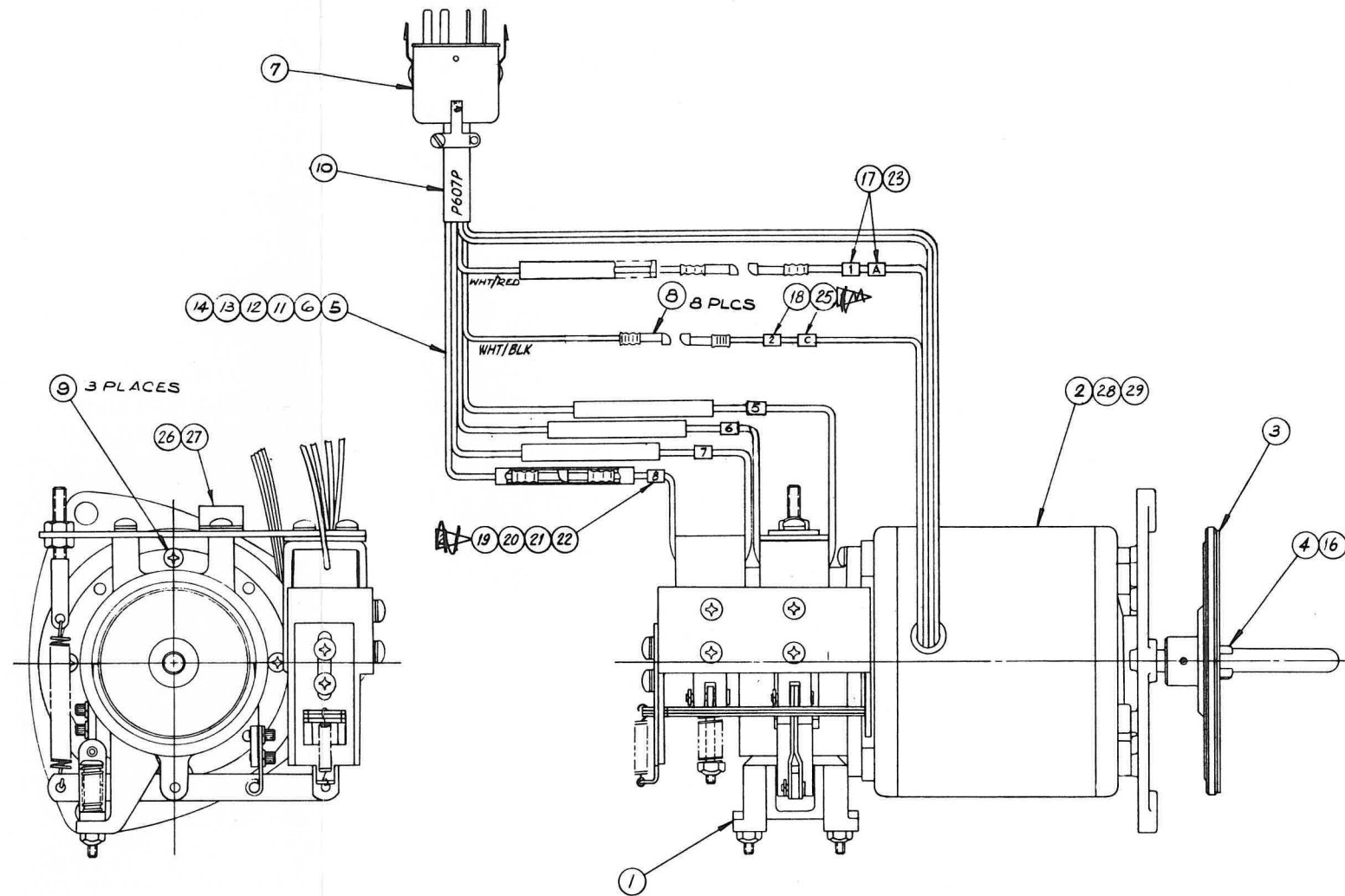

Fig. 6-13. Rewind Assembly

ITEM	-03	-04	DESCRIPTION*	Ampex Part No.
	X		Brake, assembly, takeup	4030264-03
		X	Brake, assembly, rewind	4030264-04
1	1	1	Band, assembly	4040414-10
2	2	2	Spacer	4220141-10
3	2	2	Link, brake band	4230161-10
4	1	1	Lever, brake	4230162-10
5	2	2	Link, solenoid	4230163-10
6	1	1	Bracket, solenoid	4260183-10
7	1	1	Bracket, edit solenoid	4260386-03
8		1	Bracket, edit solenoid	4260386-04
9	2	2	Spring, compression	4270163-10
10	1	1	Spring, leaf	4270164-10
11	1	1	Spring, brake	4270178-10
12	1	1	Spring, edit brake return	4270251-01
13	1	1	Spring, compression	352-085
14	1	1	Cross Head, brake	4330109-10
15	1	1	Anchor, brake	4330110-10
16	1	1	Housing, brake	4330112-10
17	2	2	Clamp, band link	4330113-10
19	1	1	Anchor, spring, edit solenoid	4330260-01
20	1	1	Bolt, spade	4400496-60
21	2	2	Solenoid, brake (K605 thru K607)	4041070-01
22	4	4	Connector, solderless	171-008

* Items of standard hardware not listed.

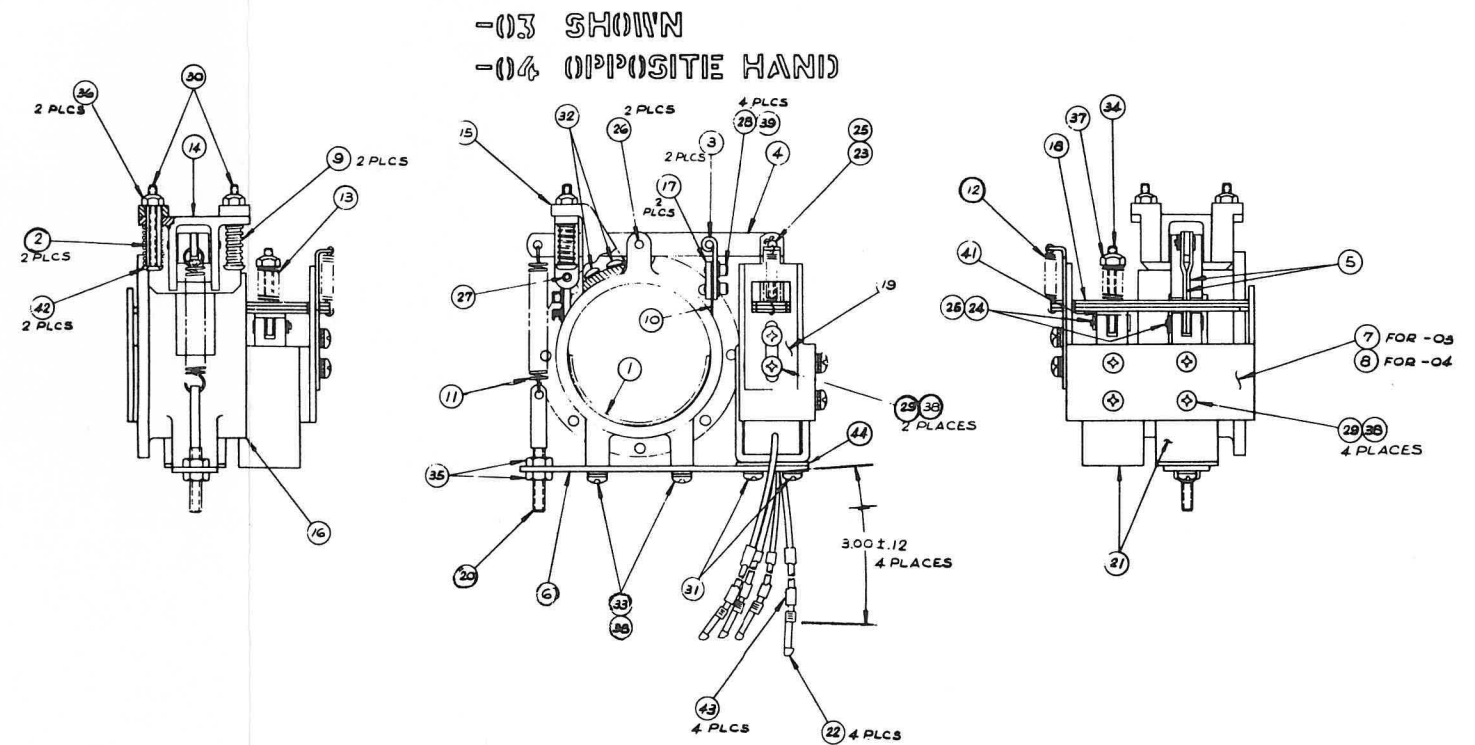
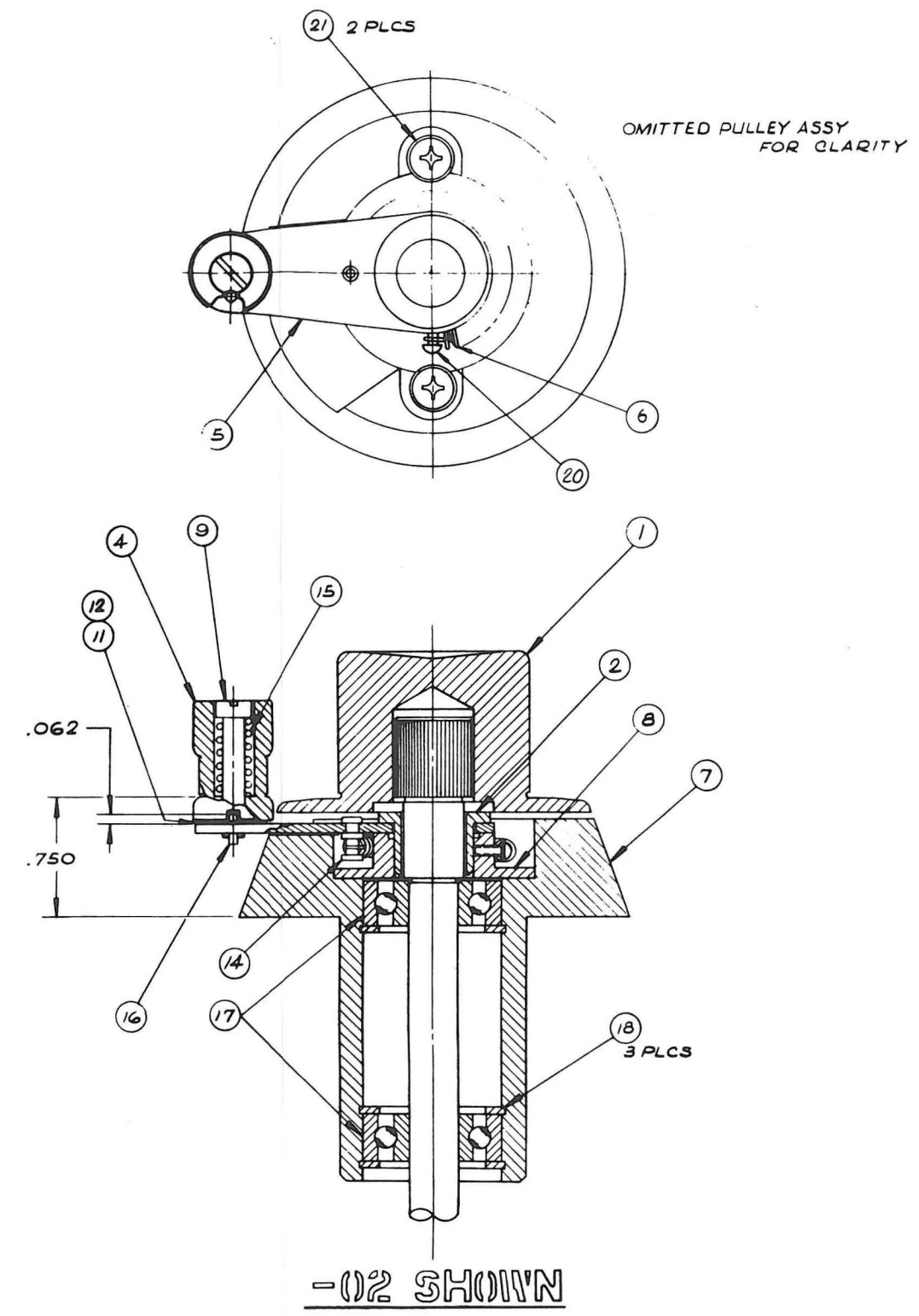

Fig. 6-14. Brake Assembly

ITEM	-02	DESCRIPTION	Ampex Part No.
	X	Reel Idler, assembly	4040970-02
1	1	Pulley, assembly	4040408-80
2	1	Bushing (see note below)	4200121-10
4	1	Tape Guide	4210311-01
5	1	Arm, reel idler (see note below)	4230245-01
6	1	Spring, tension, arm	4270160-20
7	1	Housing, reel idler	4290272-10
8	1	Mount, reel idler (see note below)	4290273-10
9	1	Screw, tape guide mounting	4400593-01
11	1	Washer, .003 thick	4440282-01
12	a/r	Washer, .025 thick	4440282-02
15	1	Spring, compression	352-084
17	2	Bearing, ball	421-116
18	3	Retaining ring, internal	430-027

NOTE
 Items 2, 5, and 8, not replaceable separately.
 Contact Ampex Technical Support, Professional Audio,
 for information if replacement is required.



DRIVE MOTOR ASSEMBLY
 CATALOG NO. 4040993E
 (See Fig. 6-16)

ITEM				DESCRIPTION	Ampex Part No.
-01	-02	-03	-04		
	X			Drive Motor, assembly, 7 1/2 and 15 ips, 60 Hz	4040993-01
		X		Drive Motor, assembly, 3 3/4 and 7 1/2 ips, 60 Hz	4040993-02
			X	Drive Motor, assembly, 7 1/2 and 15 ips, 50 Hz	4040993-03
			X	Drive Motor, assembly, 3 3/4 and 7 1/2 ips, 50 Hz	4040993-04
1	1	1		Flywheel	4250113-10
2	1			Motor, drive	4590120-01
3		1		Motor, drive	4590120-02
4			1	Motor, drive	4590121-01
5			1	Motor, drive	4590121-02
6	1	1	1	Connector, plug, 6 pins, male	145-012
7	1	1	1	Screw, set, hex socket, cup point, 10-32 x 1/4	477-336
9		1	1	Flywheel	4250114-10
<p>NOTE Capstan hard chrome plated (drive motor)</p>					

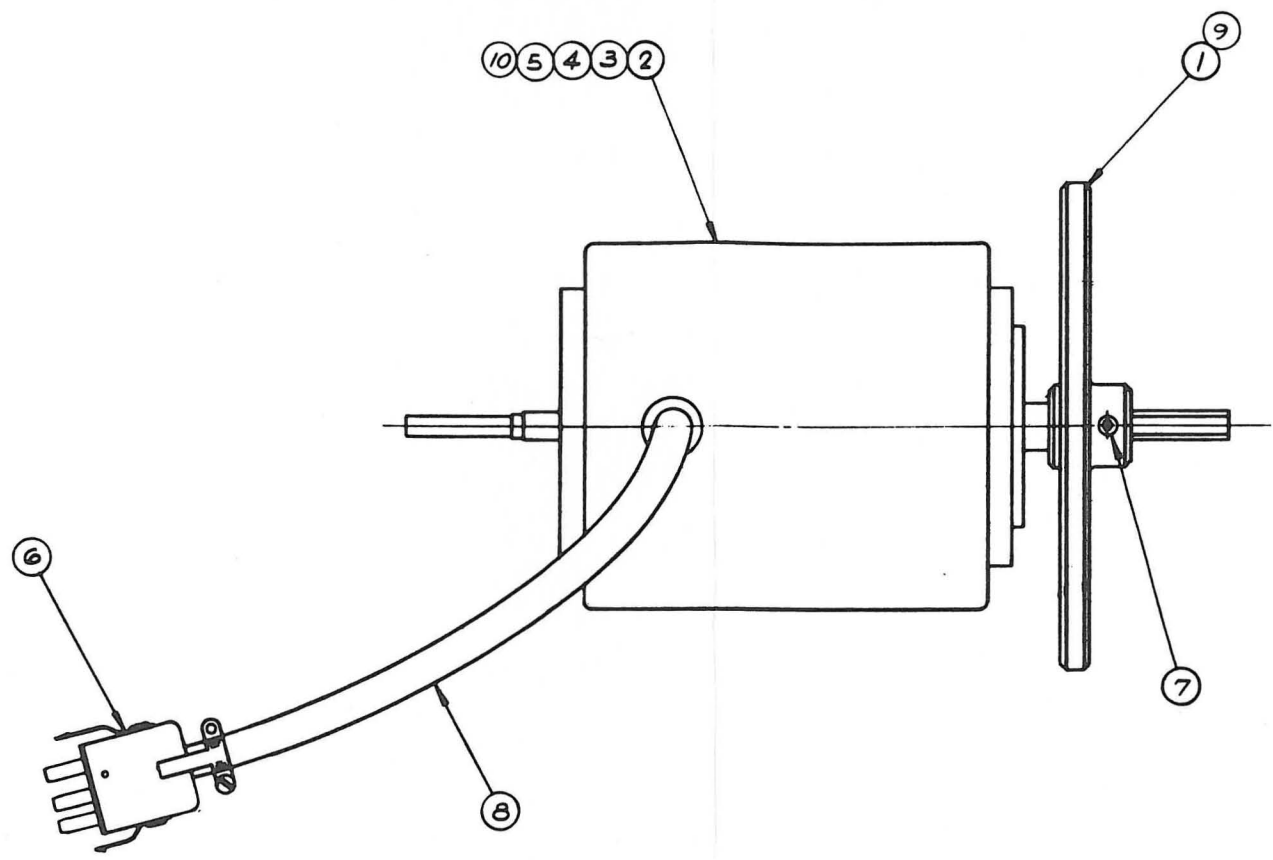
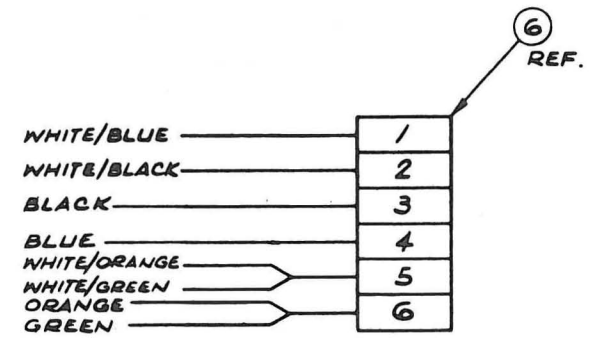

TABLE I

PART NO.	SPEED	CYCLE
4040993-01	7.5 - 15 IPS	60
4040993-02	3.75 - 7.5 IPS	60
4040993-03	7.5 - 15 IPS	50
4040993-04	3.75 - 7.5 IPS	50
4040993-05		
4040993-06	7.5 - 15 IPS	60



WIRING DIAGRAM

Fig. 6-16. Drive Motor Assembly

SECTION VI

TRANSPORT CONTROL

CONTROL BOX

4020293 (Rev. J)

(See Figs. 6-17 and 6-18)

(An alphanumerical list by electronic designation is given with Fig. 6-20)

Item	Qty	Description	Ampex Part No.
3	1	Dummy plug, remote control (P605P)	4050444-01
4	1	Printed Wiring Board, Record and Tape Lift Delay	4050472-03
5	1	Insulator, wraparound, transformer	4170108-02
6	1	Bracket, transistor mounting	4260399-01
7	1	Cover, assembly, control box	4041015-01
8	1	Transformer, power, T601	4580198-01
9	1	Shield, power transformer	4600149-01
10	2	Shield, power transformer	4600150-01
11	2	Switch, pushbutton, S608, S611	4620064-01
12	1	Lamp Holder, pilot light	4610083-01
13	1	Switch, speed, 3P.D.T., toggle, S602	4620053-01
14	2	Switch, pushbutton, normally open, S604, S605	4620144-10
15	1	Switch, pushbutton, normally closed, S606	4620144-20
16	1	Switch, pushbutton, normally open, S609	4620144-30
18	1	Switch, power, S601	4620199-01
19	2	Switch, reel, S607, S610	4620200-01
22	9	Diode, silicon, CR601-606, CR608, CR611-615	013-678
23	1	Transistor, silicon, Q601	014-611
24	1	Transistor, germanium, 40022, Q602	014-728
25	4	Relay, 4PDT, K601, K602, K603, K604	020-144
26	4	Capacitor, ceramin, .02mFd, 500 vdcw, C602-605	030-001
27	1	Capacitor, electrolytic, 500mFd, 50vdcw, C609	031-134
28	2	Capacitor, ceramin disc, .005mFd, 1400 vdcw, C606, C607	030-465
29	4	Capacitor, paper, .047mFd, 400 vdcw, C608, 613, 615, 616	035-985
30	1	Resistor, fixed, comp, 10 ohm, 10%, 1/2W, R601	041-032
31	2	Resistor, fixed, comp, 1,200 ohm, ±10%, 1W, R602, R603	041-147
32	1	Resistor, adjustable, wirewound, 750 ohm, 55W, (R607	059-013
33	4	Resistor, adjustable, wirewound, 150 ohm, 55W, R604-606, R608	059-014
34	1	Transistor, Q606	014-630
35	1	Lamp, 120V, .025 amp, DS601	060-323
36	2	Fuse, 3 amp, slo-blo, F601, F602	070-002
37	2	Fuseholder, short body	085-001
38	1	Capacitor, electrolytic, 150mFd, 180 vdcw, C614	031-624
39	1	Resistor, wirewound, 40 ohms, 20W, R609	059-236
40	1	Resistor, fixed, comp, 47,000 ohm, 1W, R611	041-166
42	4	Socket, relay	150-119
43	1	Washer, mica, transistor mounting	014-703
46	2	Washer, shoulder, nylon	503-089
49	2	Clamp, capacitor	301-011
50	2	Clamp, cable, plastic, 7/16 ID	302-006
51	1	Connector, power, male, J601S	145-501
71	2	Spacer, plain	280-026
76	2	Resistor, fixed, comp, 180 ohm, 1/2W, R610, R615	041-257
77	3	Capacitor, paper, 0.1mFd, 400 vdcw, C610-C612	035-999
78	3	Resistor, fixed, comp, 100 ohm, 1/2W, R612-614	041-038
79	4	Spring, relay hold down	020-486
		Items riveted on chassis	
	4	Connector, receptacle, 8 sockets, female, J603S, J604S, J606S, J607S	146-003
	1	Connector, receptacle, 6 sockets, female, J602S	146-004
	1	Connector, receptacle, 12 sockets, female, J605S	146-009
84	1	Fuse, 1/2 amp, slo-blo, 120V, F603	070-026

Items of standard hardware, wire, etc., not listed.

NOTE: Resistor tolerances are 10% unless noted otherwise.

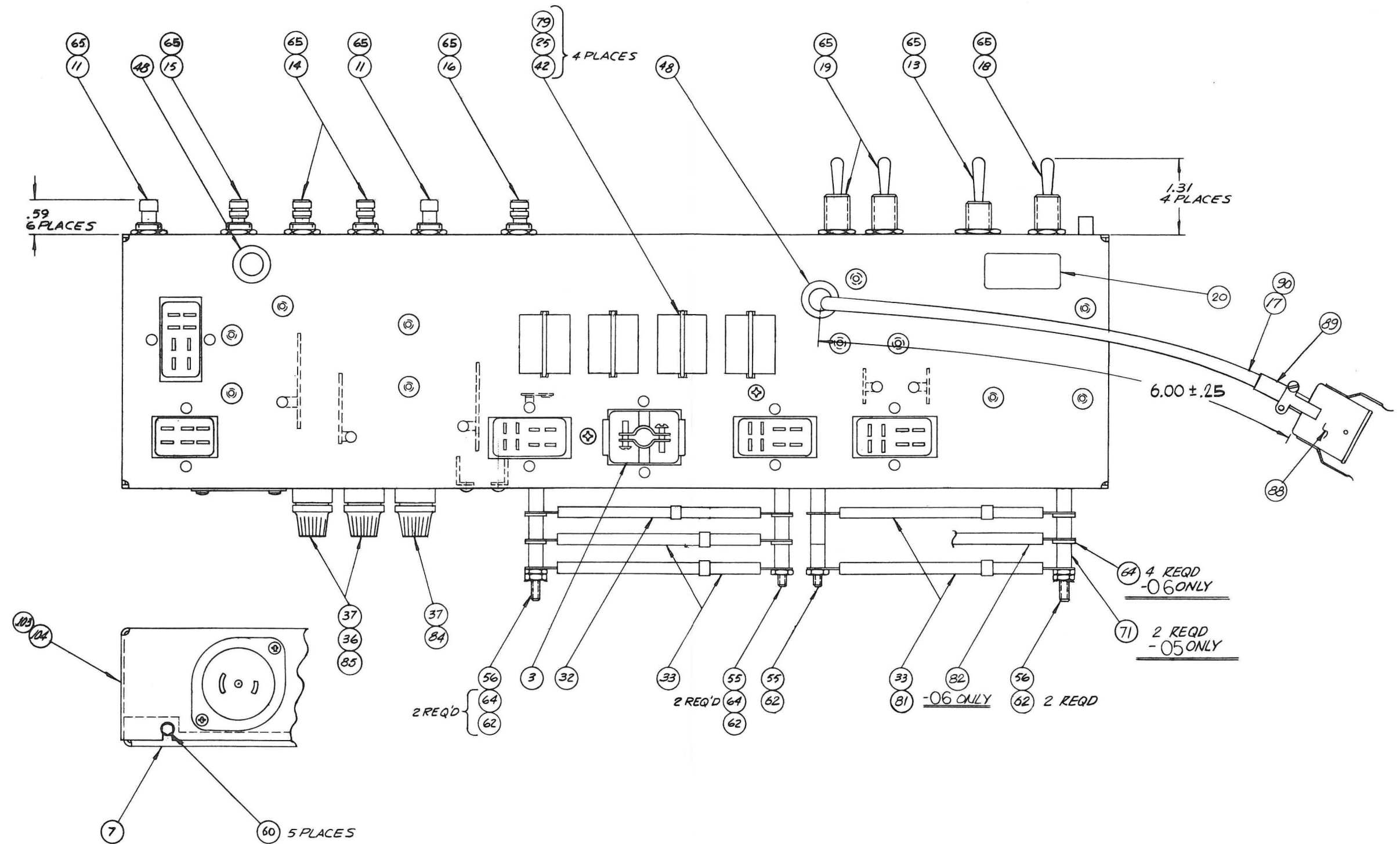

Fig. 6-17. Control Box, Top

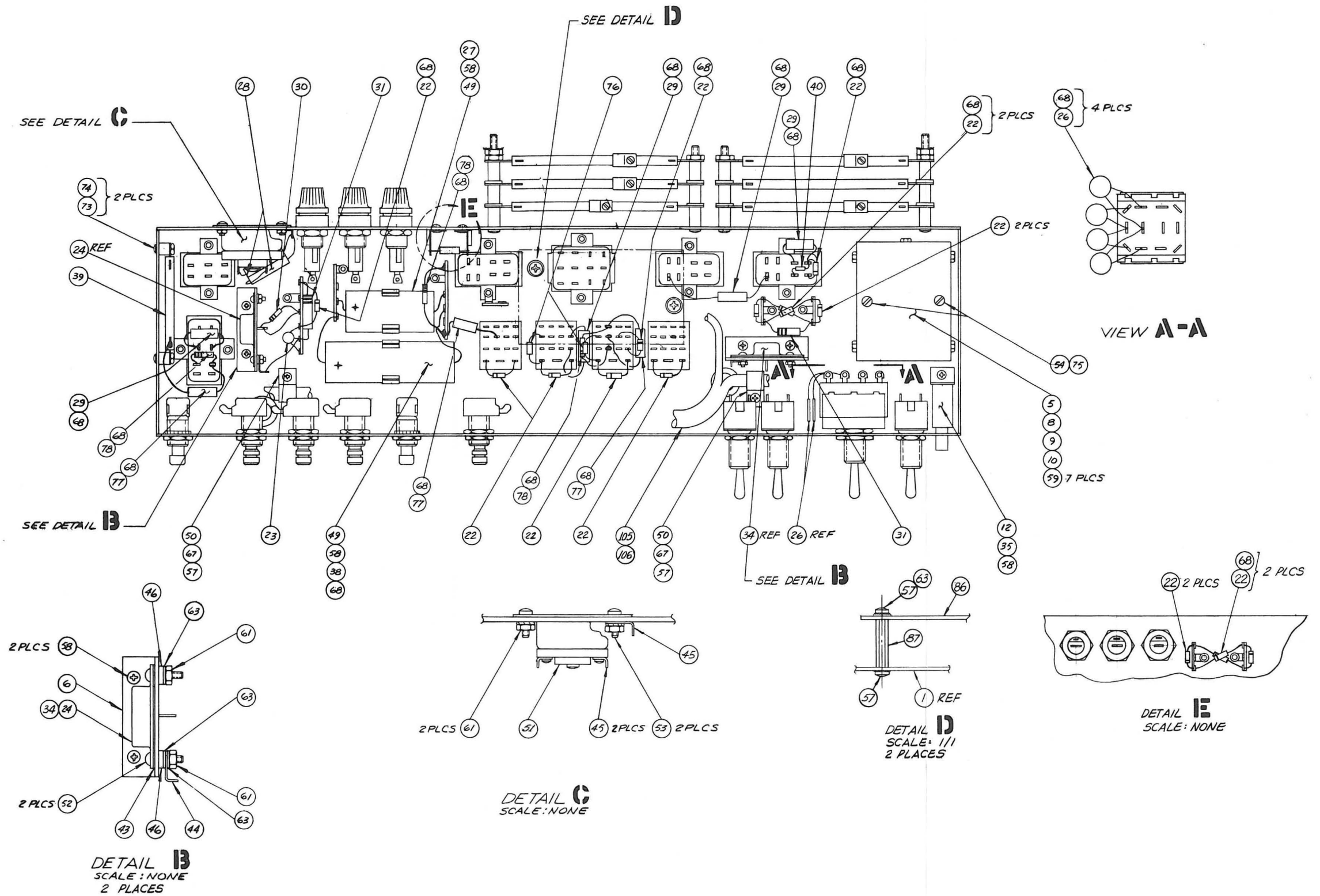

Fig. 6-18. Control Box, Inner

SECTION VI

ELECTRONICS

Item No.	-03	DESCRIPTION	Ref. No.	Ampex Part No.
1	1	Printed Wiring Board		4500035-01
5	5	Diode, Silicon	CR613, 619-622	013-678
4	1	Transistor	Q605	014-247
8	1	Capacitor, Electrolytic, 75 μ F, 50V	C619	031-939
9	1	Capacitor, Electrolytic, 10 μ F, 50V	C621	031-940
10	1	Resistor, Composition, 1K ohm, 2W, 10%	R625	041-202
11	1	Resistor, Composition, 22K ohm, 1/4W, 10%	R620	041-630
12	1	Resistor, Composition, 15K ohm, 1/4W, 10%	R618	041-631
13	3	Resistor, Composition, 10K ohm, 1/4W, 10%	R616, 621, 622	041-633
14	1	Resistor, Composition, 680 ohm, 1/4W, 10%	R617	049-334
15	1	Resistor, Composition, 33K ohm, 1/4W, 10%	R624	049-371
16	1	Resistor, Composition, 47K, 1/4W, 10%	R623	049-372
17	1	Resistor, Variable, 500K ohm,	R619	058-364
18	1	Transistor, Silicon	Q603	580-089
19	1	Capacitor, Tantalum, 330 μ F, 6V	C620	037-072
36	REF	Schematic		4840183
37	REF	Schematic		4840184
20	1	Transistor	Q604	014-698
3	1	Transistor Mounting Pad	Q605	280-131

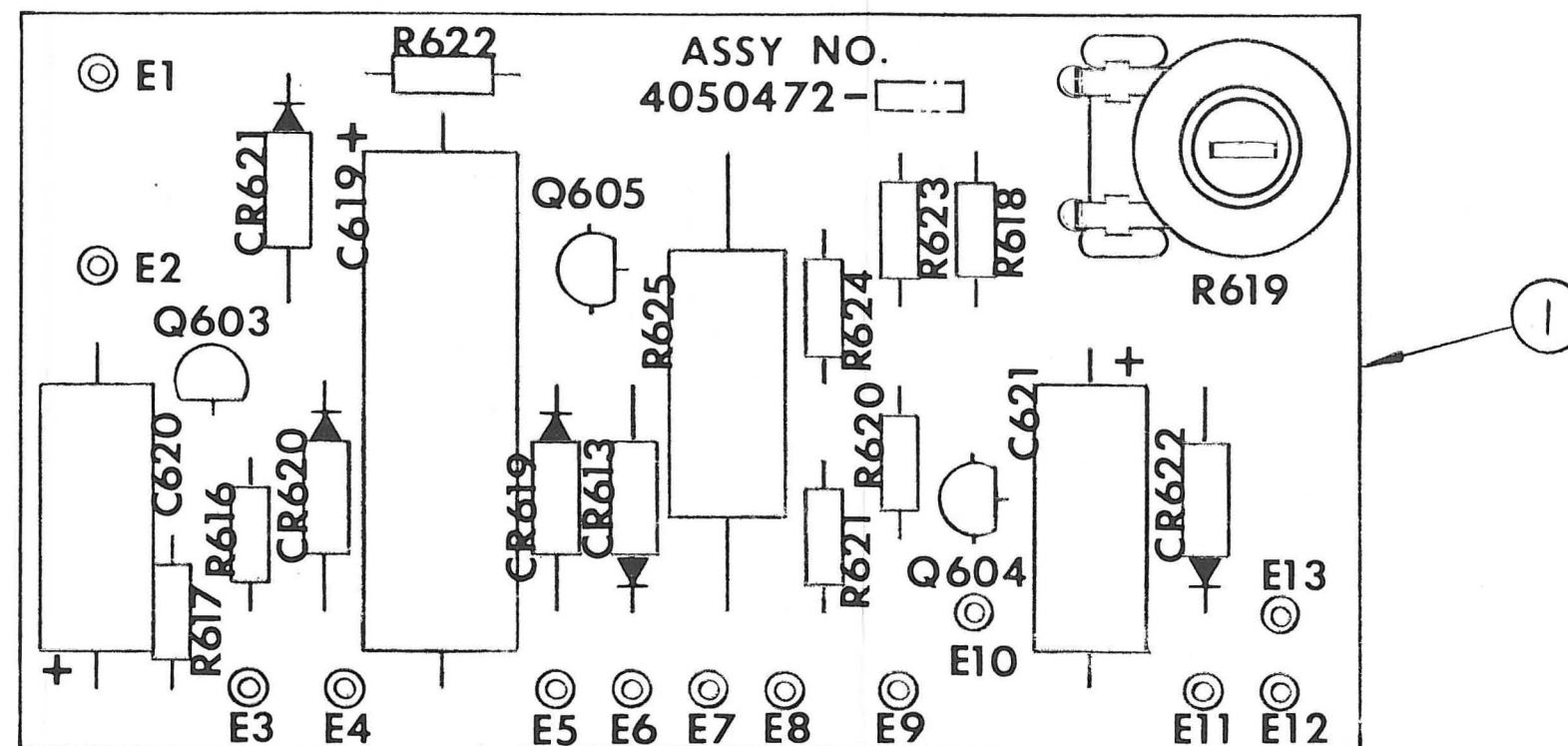

Fig. 6-19. Printed Wiring Assembly,
 Record and Tape Lift Delay

ELECTRONIC COMPONENTS, TAPE TRANSPORT (Fig. 6-20)

4890301

(Location of control box components shown in Figs. 6-17 and 6-18)

Ref. No.	Qty	DESCRIPTION	LOCATION *	Ampex Part No.
B601	1	Motor, drive, assembly (see Fig. 6-16)	T	4040993
B602	1	Motor, takeup, assembly (see Fig. 6-12)	T	4040969-02
B603	1	Motor, rewind, assembly (see Fig. 6-13)	T	4040969-01
C601	1	Capacitor, assembly, drive motor	T	4040591-02
	1	Capacitor, 5.0 mfd, 330 vac		4540292-30
	1	Safety Boot		032-082
	2	Solderless Connectors		171-008
C602	4	Capacitor, ceramic disc; .02 mfd, 500 vdcw	CB	030-001
C603	-	Same as C602	CB	
C604	-	Same as C602	CB	
C605	-	Same as C602	CB	
C606	2	Capacitor, ceramic disc; .005 mfd, -20+80%, 1400 vdcw	CB	030-465
C608	4	Capacitor, mylar, tubular; .047 mfd, ±20%, 400 vdcw	CB	035-985
C609	1	Capacitor, electrolytic; 500 mfd, -10+150%, 50 vdcw	CB	031-134
C610	3	Capacitor, mylar, tubular; 0.1 mfd, ±10%, 400 vdcw	CB	035-999
C611	-	Same as C610	CB	
C612	-	Same as C610	CB	
C613	-	Same as C608	CB	
C614	1	Capacitor, electrolytic; 150 mfd, -10+100%, 180 vdcw	CB	031-624
C615	-	Same as C608	CB	
C616	-	Same as C608	CB	
C617	2	Capacitor, assembly, takeup motor	T	4050361-10
	2	Capacitor, 10 mfd, 236 vac		4540312-10
	2	Safety Boot		032-082
	4	Solderless Connectors		171-008
C620	1	Capacitor, tantalum, 330 mfd, 6 vdcw	CB	037-072
C618	-	Same as C617, for rewind motor	T	
CR601	15	Diode, silicon, large signal, rectifier	CB	013-678
CR602	-	Same as CR601	CB	
CR603	-	Same as CR601	CB	
CR604	-	Same as CR601	CB	
CR605	-	Same as CR601	CB	
CR606	-	Same as CR601	CB	
CR608	-	Same as CR601	CB	
CR609	-	Same as CR601	CB	
CR611	-	Same as CR601	CB	
CR612	-	Same as CR601	CB	
CR613	-	Same as CR601	CB	
CR614	-	Same as CR601	CB	
CR615	-	Same as CR601	CB	
CR616	-	Same as CR601	CB	
CR617	-	Same as CR601	CB	
CR618	-	Same as CR601	CB	
DS601	1	Lamp, incandescent; 120 volts, .025 amp	CB	060-323
F601	2	Fuse, slo-blo; 3 amps, 125 volts	CB	070-002
F602	-	Same as F601	CB	
F603	1	Fuse, slo-blo, 1/2 amp, 125 vac	CB	070-026
J601S	1	Connector, power, 3 contacts, male; flush base, polarized	CB	147-079
J602S	1	Connector, receptacle, 6 sockets, female	CB	146-004
J603S	4	Connector, receptacle, 8 sockets, female	CB	146-003
J604S	-	Same as J603S	CB	
J605S	1	Connector, receptacle, 12 sockets, female	CB	146-009
J606S	-	Same as J603S	CB	
J607S	-	Same as J603S	CB	
K601	4	Relay, armature, 4P2T; 24 volts, 650 ohms; with nylon dust cover	CB	020-144
K602	-	Same as K601	CB	
K603	-	Same as K601	CB	
K604	-	Same as K601	CB	
K605	4	Solenoid, takeup, main brake (see Fig. 6-14)	T	4041070-01
K606	-	Same as K605 (takeup edit brake) (see Fig. 6-14)	T	
K607	-	Same as K605 (supply main brake) (see Fig. 6-14)	T	

*T - Transport, CB - Control Box

ELECTRONIC COMPONENTS, TAPE TRANSPORT

(2 of 2)

Ref. No.	Qty	DESCRIPTION	LOCATION *	Ampex Part No.
K608	-	Same as K605 (supply edit brake) (see Fig. 6-14)	T	
K609	1	Solenoid, assembly, tape lifter (see Figs. 6-8 and 6-9)	T	4030273
K610	1	Solenoid, assembly, capstan idler (see Figs. 6-8 and 6-9).	T	4030272
P601		Not used		
P602	1	Connector, plug, 6 pins, male (drive motor--see Fig. 6-16)	T	145-012
P603	2	Connector, plug, 8 pins, male (takeup motor--see Fig. 6-12)	T	145-013
P604P	1	Dummy Plug, motor drive amplifier	CB	4050138-10
P605P	1	Dummy Plug, remote control	CB	4050444-01
P606P		Not used		
P607P	-	Same as P603P (rewind motor--see Fig. 6-13)	T	
Q601	1	Transistor, silicon, pnp, 300mw	CB	014-611
Q602	1	Transistor, Germanium, power, pnp; 40022	CB	014-728
Q606	1	Transistor, silicon, npn, power	CB	014-630
R601	1	Resistor, fixed, comp; 10 ohms, $\pm 10\%$, 1/2w; RC20GF100K	CB	041-032
R602	2	Resistor, fixed, comp; 1,200 ohms, $\pm 10\%$, 1w; RC32GF122K	CB	041-147
R603	-	Same as R602	CB	
R604	2	Resistor, wirewound, adjustable; 150 ohms, $\pm 10\%$, 55w	CB	059-014
R605	-	Same as R604	CB	
R607	1	Resistor, wirewound, adjustable; 750 ohms, $\pm 10\%$, 55w	CB	059-013
R609	1	Resistor, wirewound, fixed; 40 ohms, $\pm 5\%$, 20w	CB	059-236
R610				
R611				
R612	3	Resistor, fixed, comp; 100 ohms, $\pm 10\%$, 1/2w; RC20GF101K	CB	041-038
R613	-	Same as R612	CB	
R614	-	Same as R612	CB	
R615				
S601	1	Switch, power, toggle; DPST, 2 position	CB	4620199-01
S602	1	Switch, speed, toggle; 3 PDT, 2 position (on-on)	CB	4620053-01
S603	1	Switch, safety, assembly; (switch only, Part No. 4620145-01)	CB	4050436-01
S604	2	Switch, fast forward, pushbutton; normally open	CB	4620144-10
S605	-	Same as S604, (rewind pushbutton)	CB	
S606	1	Switch, stop, pushbutton; normally closed	CB	4620144-20
S607	2	Switch, reel, takeup; toggle; SPST	CB	4620200-01
S608	2	Switch, play, pushbutton; 2 circuit	CB	4620064-01
S609	1	Switch, record, pushbutton; normally open	CB	4620144-30
S610	-	Same as S607; (rewind pushbutton)	CB	
S611	-	Same as S608; (edit pushbutton)	CB	
T601	1	Transformer, power	CB	4580198-01

* T - Transport, CB- Control Box

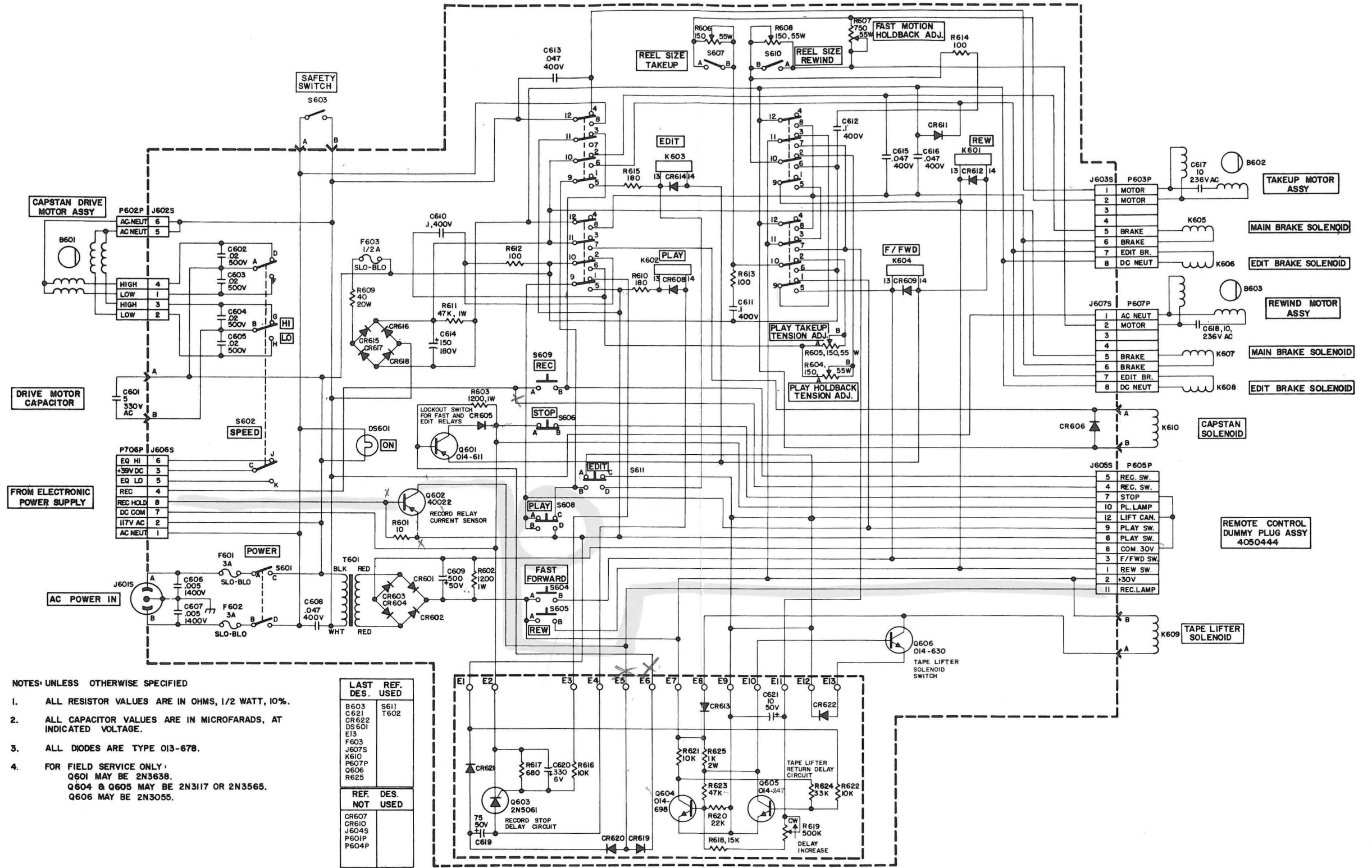
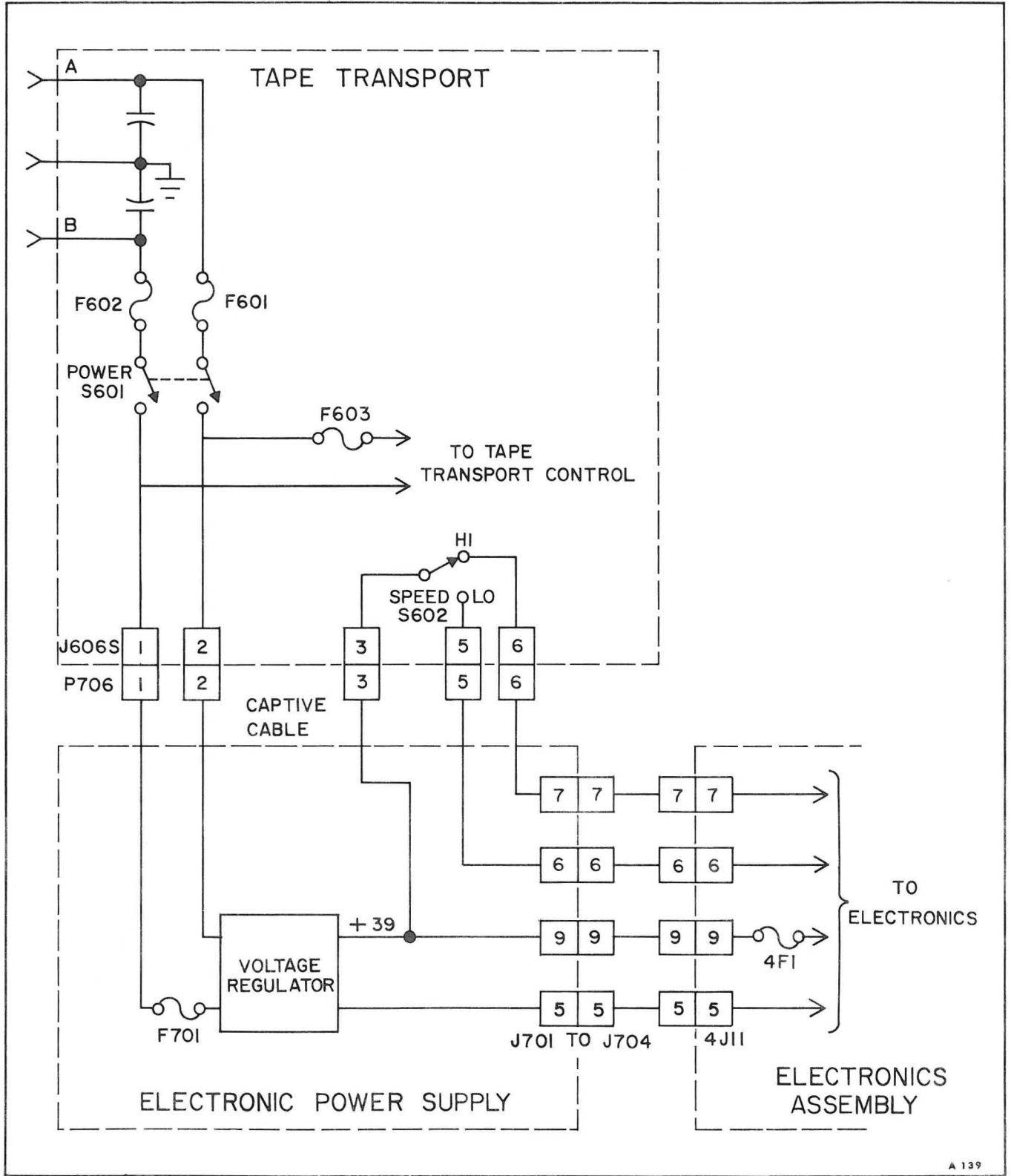

Fig. 6-20. Schematic Diagram, Transport



A 139

Fig. 6-21. Schematic Diagram, Transport Power Supply

RECORD/REPRODUCE POWER SUPPLY ASSEMBLY

4020274-03 (Rev. H)

(See Fig. 6-22 for Cable See Fig. 6-35)

Ref. No.	Qty	Description	Ampex Part No.
C701	1	Capacitor, mica; 6800pFd, $\pm 5\%$, 500 vdcw	056-108
C702	2	Capacitor, mica; 5600pFd, $\pm 5\%$, 300 vdcw	034-507
C703	-	Same As C702	
C704	1	Capacitor, mica; 2500pFd, $\pm 5\%$, 500 vdcw	034-994
C705	1	Capacitor, mylar; 0.1mFd, $\pm 10\%$, 100 vdcw	055-106
C706	1	Capacitor, electrolytic; 500mFd, $-10+150\%$, 50 vdcw	* 031-945
C707	1	Capacitor, electrolytic; 2000mFd, $-10+250\%$, 80 vdcw	* 4550147-03
C709	2	Capacitor, electrolytic; 5mFd, $-10+75\%$, 50 vdcw	* 031-205
C710	-	Same as C709	
CR701	4	Diode, silicon, large signal rectifier	* 013-678
CR702	-	Same As CR701	*
CR703	-	Same As CR701	*
CR704	-	Same As CR701	*
CR705	3	Diode, silicon, small signal switching	013-599
CR706	-	Same As CR705	
CR707	1	Same As CR705	
F701	1	Fuse, slo-blo; 1.5 amp, 125v	* 070-075
J701	4	Connector, receptacle; 10 seockets, female	* 146-018
J702	-	Same As J701	*
J703	-	Same As J701	*
J704	-	Same As J701	*
P706	1	Connector, plug; 8 pins, male	* 145-013
Q701	3	Transistor, silicon	014-653
Q702	-	Same As Q701	
Q703	1	Transistor, Germanium, 2N398A	014-704
Q704	1	Transistor, silicon; 2N3053	014-590
Q705	1	Transistor, silicon, 2N4348	014-796
Q706	-	Same As Q701	
R701	2	Resistor, fixed, comp; 24 ohm, $\pm 5\%$, 1/2W, RC20GF240J	041-533
R702	-	Same As R701	
R703	2	Resistor, fixed, comp; 22,000 ohm, $\pm 10\%$, 1/2W, RC20GF223K	041-064
R704	-	Same As R703	
R705	1	Resistor, fixed, comp; 1,200 ohm, $\pm 10\%$, 1W, RC32GF122K	041-147
R706	1	Resistor, fixed, comp; 10,000 ohms, $\pm 10\%$, 1W; RC32GF103K	* 041-158
R707	1	Resistor, fixed, comp; 20,000 ohm, $\pm 10\%$, 1/2W, RC20GF203K	041-529
R708	1	Resistor, fixed, comp; 1,000 ohm, $\pm 10\%$, 1/2W, RC20GF120K	041-048
R709	1	Resistor, fixed, wirewound, 1 ohm, $\pm 5\%$, 5W	059-016
R710	2	Resistor, fixed, comp, 2,200 ohm, $\pm 10\%$, 1/2W, RC20GF222K	041-052
R711	1	Resistor, fixed, comp, 3,900 ohm, $\pm 10\%$, 1/2W, RC20GF392K	041-055
R712	1	Resistor, variable, comp; 1,000 ohm, $\pm 30\%$, 1/10W	044-370
R713	-	Same As R710	
R714	1	Resistor, fixed, comp; 100 ohms, $\pm 10\%$, 1/2W, RC20GF101K	041-038
T701	1	Coil, bias oscillator	4580123-01
T702	1	Transformer, power supply	* 4580156-01
VR701	1	Diode, silicon, zener; 13 volt, $\pm 5\%$	013-747
VR702	1	Diode, silicon, zener; 24 volt, $\pm 5\%$	013-712
	2	Card Guide	530-102
	1	Fuse holder, short body	085-001
	2	Pad, transistor (for Q703, Q704)	280-131

NOTE: All items except those marked with * are on printed circuit board,
Catalog No. 4050432-05

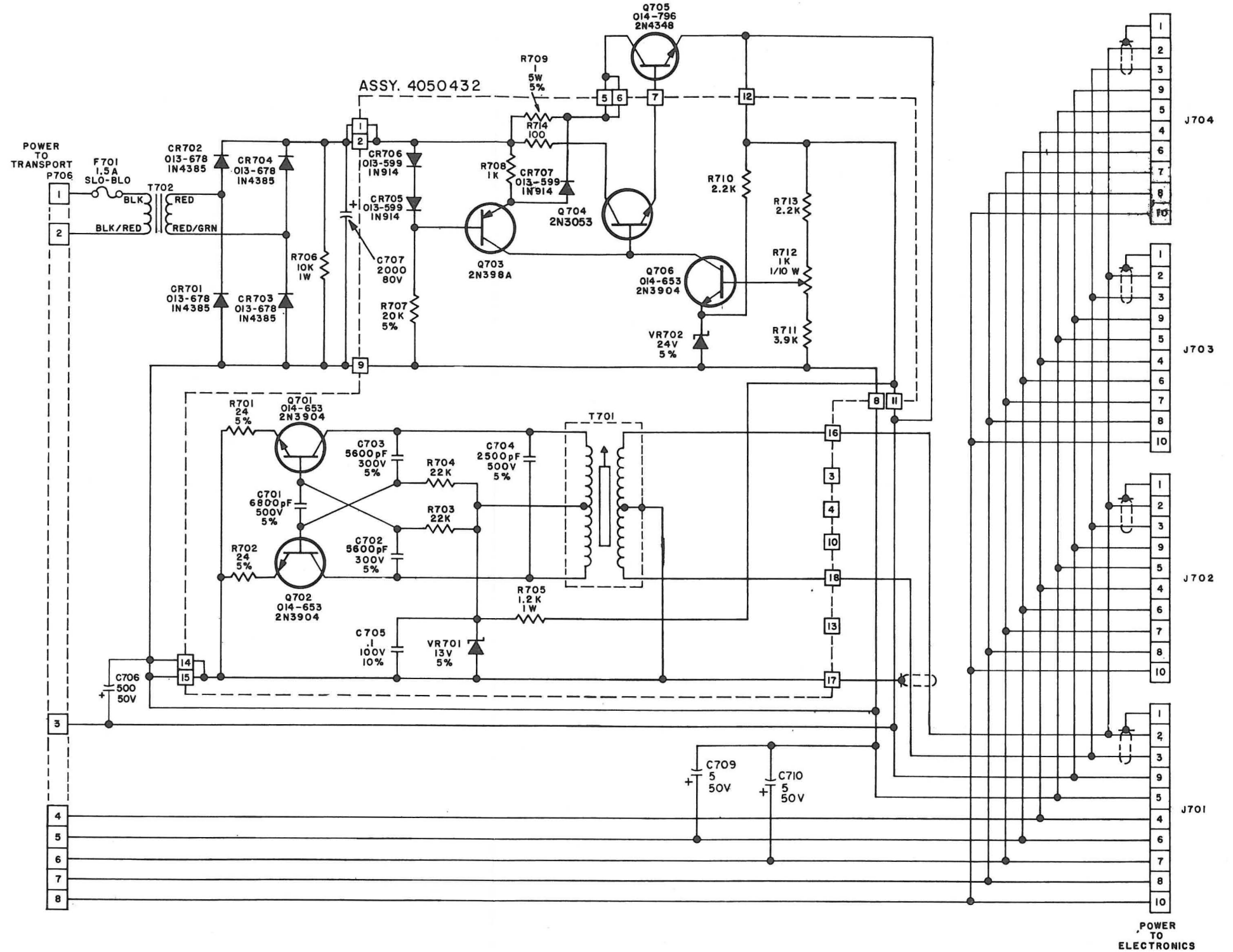

UNLESS OTHERWISE SPECIFIED
 ALL CAPACITOR VALUES ARE IN MICROFARADS, RATINGS AS INDICATED.
 ALL RESISTORS VALUES ARE IN OHMS, 1/2 WATT, 10%.

Fig. 6-22. Power Supply Schematic, Record/Reproduce

REGULATOR & OSCILLATOR
PRINTED WIRING BOARD ASSEMBLY
Ampex 4050432 (Ref. J)

4890301

Item No.	AG-440B -05	AG445B -06	DESCRIPTION	Ref. No.	Ampex Part No.
1	1	1	Printed Wiring Board		4500105-02
2	1		Bias Oscillator Coil	T701	
3	3	3	Diode, CD458	CR705-707	013-599
4	1	1	Zener, 24V, 5%	VR702	013-712
5	1		Zener, 13V, 5%	VR701	013-747
6	1	1	Transistor, 2N3053	Q704	014-590
7	3	1	Transistor, CD525	Q701, 702, 706	014-653
9	1	1	Transistor, 2N398A	Q703	014-704
11	1		Capacitor, Mica, 2500PF, 500V, 5%	C704	034-994
12	2		Capacitor, Mica, 5600PF, 300V, 5%	C702, 703	034-507
13	1	1	Resistor, Fixed, 1K ohm, 1/2W, 10%	R708	041-048
14	2	2	Resistor, Fixed, 2.2K ohm, 1/2W, 10%	R710, 713	041-052
15	1	1	Resistor, Fixed, 3.9K ohm, 1/2W, 10%	R711	014-055
16	2		Resistor, Fixed, 22K ohm, 1/2W, 10%	R703, 704	041-064
18	1		Resistor, Fixed, 1.2K ohm, 1W, 10%	R705	041-147
19	2		Resistor, Fixed, 24 ohm, 1/2W, 5%	R701, 702	041-533
20	1	1	Resistor, Variable, 1K ohm, 1/10W	R712	044-370
21	1		Capacitor, Mylar, .1 μ F, 100V, 10%	C705	055-106
22	1		Capacitor, Mica, 6800PF, 500V, 5%	C701	056-108
23	1	1	Resistor, 1 ohm, 5W, 5%	R709	059-016
24	1	1	Resistor, 20K ohm, 1/2W, 5%	R707	041-529
26	2	2	Transistor Pad		280-131
27	1	1	Resistor, Fixed, 100 ohm, 1/2W, 10%	R714	041-038

REPRODUCE-ONLY POWER SUPPLY ASSEMBLY

4020274-04 (Rev. H)

(See Fig. 6-23, for Cable See Fig. 6-35)

Ref. No.	Qty	Description	Ampex Part No.
C706	1	Capacitor, electrolytic; 500mFd, -10+150%, 50 vdcw	031-945
C707	1	Capacitor, electrolytic; 2000mFd, -10+250%, 80 vdcw	* 4550147-03
C708	1	Capacitor, mylar; 0.1mFd, ±10%, 100 vdcw	055-106
C709	2	Capacitor, electrolytic; 5mFd, -10+75%, 50 vdcw	031-205
C710	-	Same As C709	
CR701	4	Diode, silicon, large signal rectifier	* 013-678
CR702	-	Same As CR701	*
CR703	-	Same As CR701	*
CR704	-	Same As CR701	*
CR705	3	Diode, silicon, small signal switching	013-599
CR706	-	Same As CR705	
CR707	-	Same As CR705	
F701	1	Fuse, slo-blo; 1.5 amp, 125V	* 070-075
J701	4	Connector, receptacle; 10 sockets, female	* 146-018
J702	-	Same As J701	*
J703	-	Same As J701	*
J704	-	Same As J701	*
P706	1	Connector, plug; 8 pins, male	* 145-013
Q703	1	Transistor, Germanium, 2N398A	014-704
Q704	1	Transistor, silicon; 2N3053	014-590
Q705	1	Transistor, silicon, 2N4348	* 014-796
Q706	1	Transistor, silicon	014-653
R706	1	Resistor, fixed, comp, 10,000 ohm, ±10%, 1W, RC32GF103K	* 041-158
R707	1	Resistor, fixed, comp, 20,000 ohm, ±10%, 1/2W, RC20GF203K	041-529
R708	1	Resistor, fixed, comp, 1,000 ohm, ±10%, 1/2W, RC20GF102K	041-048
R709	1	Resistor, fixed, wirewound, 1 ohm, ±5%, 5W	059-016
R710	2	Resistor, fixed, comp, 2,200 ohm, ±10%, 1/2W, RC20GF222K	041-052
R711	1	Resistor, fixed, comp, 3,900 ohm, ±10%, 1/2W, RC20GF392K	041-055
R712	1	Resistor, variable, comp, 1,000 ohm, ±30%, 1/10W	044-370
R713	-	Same As R710	
R714	1	Resistor, fixed, comp, 100 ohm, ±10%, 1/2W, RC20GF101K	041-038
T702	1	Transformer, power supply	* 4580156-01
VR702	1	Diode, silicon, zener; 24 volt, ±5%	013-712
	2	Card Guide	530-102
	1	Fuse holder, short body	085-001
	2	Pad, transistor, for Q703, Q704	280-131

NOTE: All items except those marked with * are on printed circuit board, catalog no. 4050432-06.

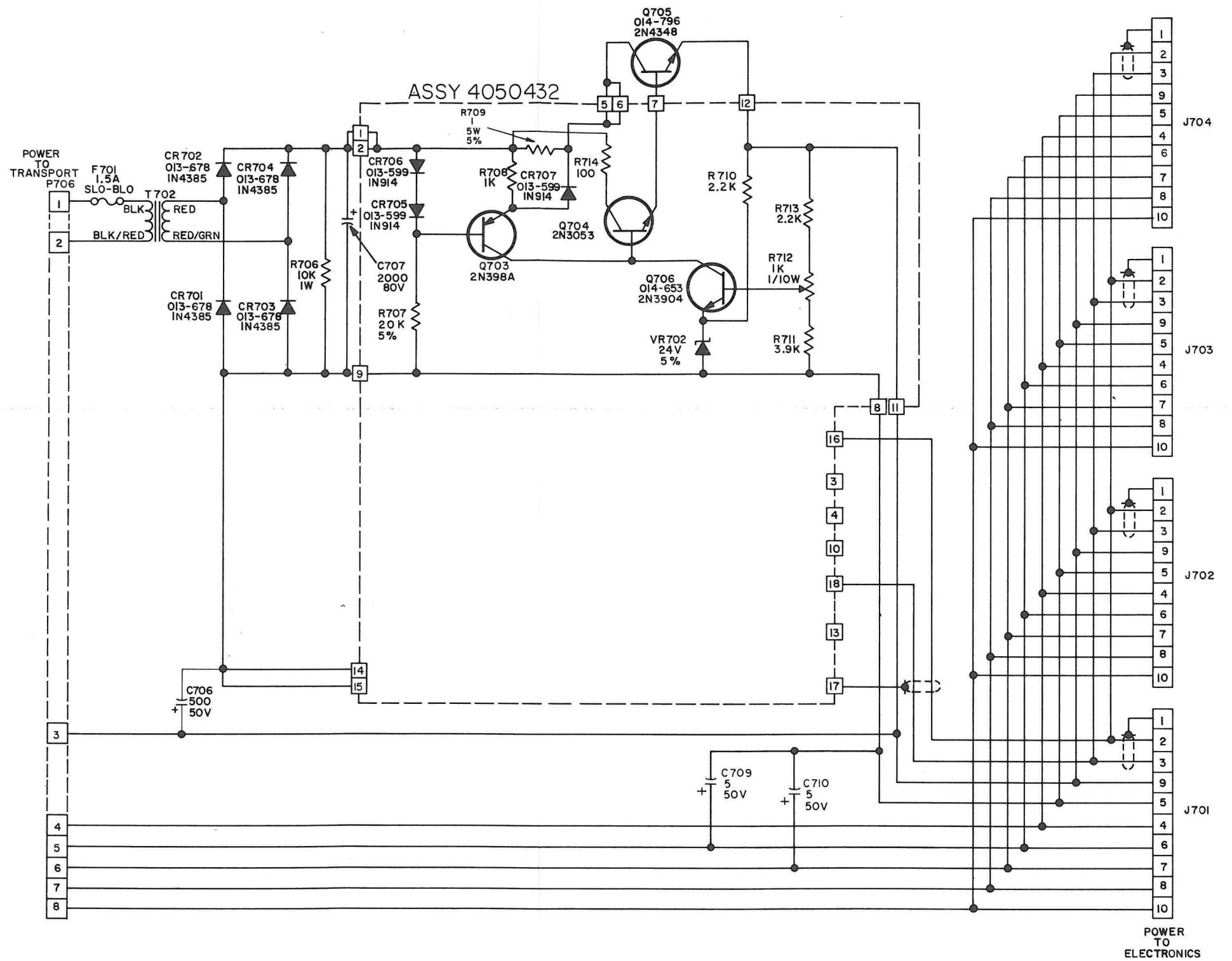

UNLESS OTHERWISE SPECIFIED
 ALL CAPACITOR VALUES ARE IN MICROFARADS, RATINGS AS INDICATED.
 ALL RESISTOR VALUES ARE IN OHMS, 1/2WATT, 10%

Fig. 6-23. Power Supply Schematic,
 Reproduce-only

ELECTRONICS ASSEMBLY WITHOUT EQUALIZER				CATALOG NO. 4020260		SHEET 1 OF 1	
				NHA 4010131-134			
ITEM NO.	AMPEX PART NO.	VENDOR OR MIL. NO.	SCHEMATIC REFERENCE	PART DESCRIPTION	QUANTITY REQUIRED PER VERSION		
					-10	-11	-12
1	4030034-30			DUMMY PLUG ASSEMBLY	1	1	1
2	4030269-01		J10	CONNECTOR ASSEMBLY, 12 Contact	1	1	1
3	4030269-02		J13	CONNECTOR ASSEMBLY, 12 Contact	1	1	1
4	4030269-03		J3	CONNECTOR ASSEMBLY, 12 Contact	1	1	1
5	4040959-01			PANEL, Left Side	1	1	1
6	4040975-01			ENCLOSURE, Module	1	1	1
7	4040978-01			COVER, Electronics	1	1	1
8	4040978-02			COVER, Electronics	1	1	1
9	4040992-01			COVER PANEL, Decorative	1	1	1
10	4040994-01			SHIELD, Module Enclosure	1	1	1
13	4050435-03			PRINTED WIRING ASSEMBLY, Reproduce Amplifier	1	-	-
15	4050438-04			FRONT PANEL ASSEMBLY	1	1	-
17	4050440-02			BRACKET ASSEMBLY, Capacitor Mounting	1	1	1
19	4220245-01			SPACER, Chassis	1	1	1
20	4230133-02			GUIDE, Printed Wiring Board	6	6	6
21	4290187-01			SHIELD, Enclosure, rear	1	1	1
22	4290188-01			SHIELD, Selector Switch	1	1	1
23	4290661-01			COVER, Module Enclosure	1	1	1
24	4290661-02			COVER, Module Enclosure	1	1	1
25	6000035-02			LABEL, Identification	1	1	1
26	4050468-01			JUMPER PLUG ASSEMBLY, Electronics	1	1	-
27	4050434-01			PRINTED WIRING BOARD ASSEMBLY, Record	1	1	1
28	031-126		C15	CAPACITOR, Electrolytic, 250MF, 50V	1	1	1
29	041-455		R37	RESISTOR, 6.2K ohm, 1/2W, 5%	1	1	1
30	302-007			CABLE CLAMP, Plastic, 1/4"	1	1	1
31	302-036			CABLE CLAMP, Plastic, 3/8"	1	-	-
54	4050433-04			PRINTED WIRING BOARD, Bias Amplifier	-	-	1
55	4050433-05			PRINTED WIRING BOARD, Bias Amplifier	1	1	-
57	4050435-05			PRINTED WIRING BOARD ASSEMBLY, Reproduce Amplifier	-	1	-
59	4050554-01			FRONT PANEL ASSEMBLY	-	-	1
61	4050435-07			PRINTED WIRING BOARD ASSEMBLY, Reproduce Board	-	-	1

4020260AA

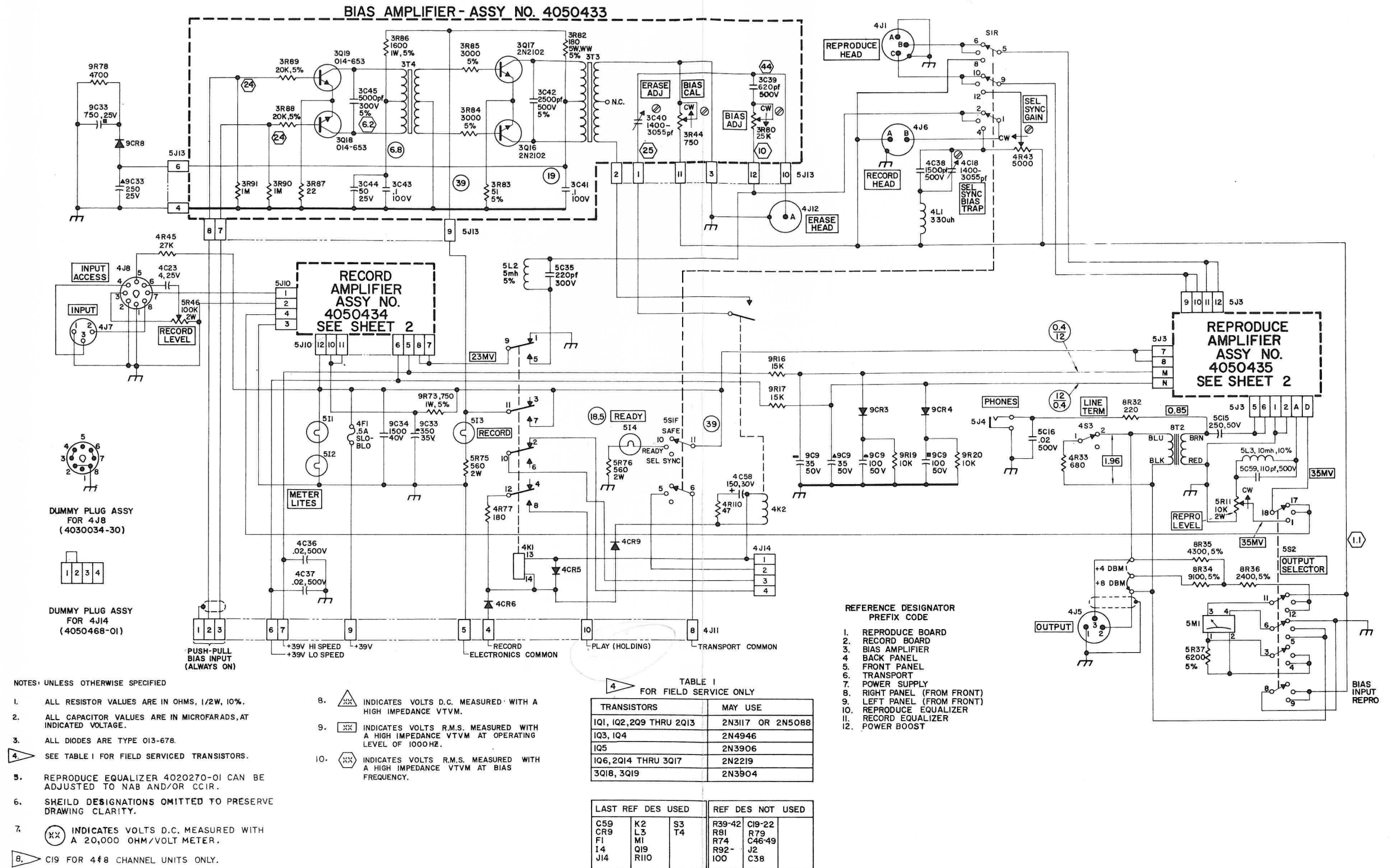
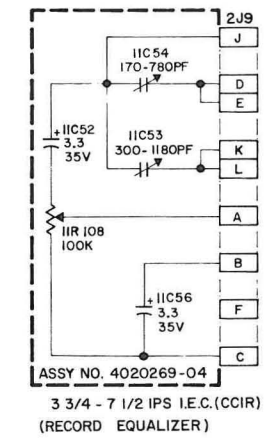
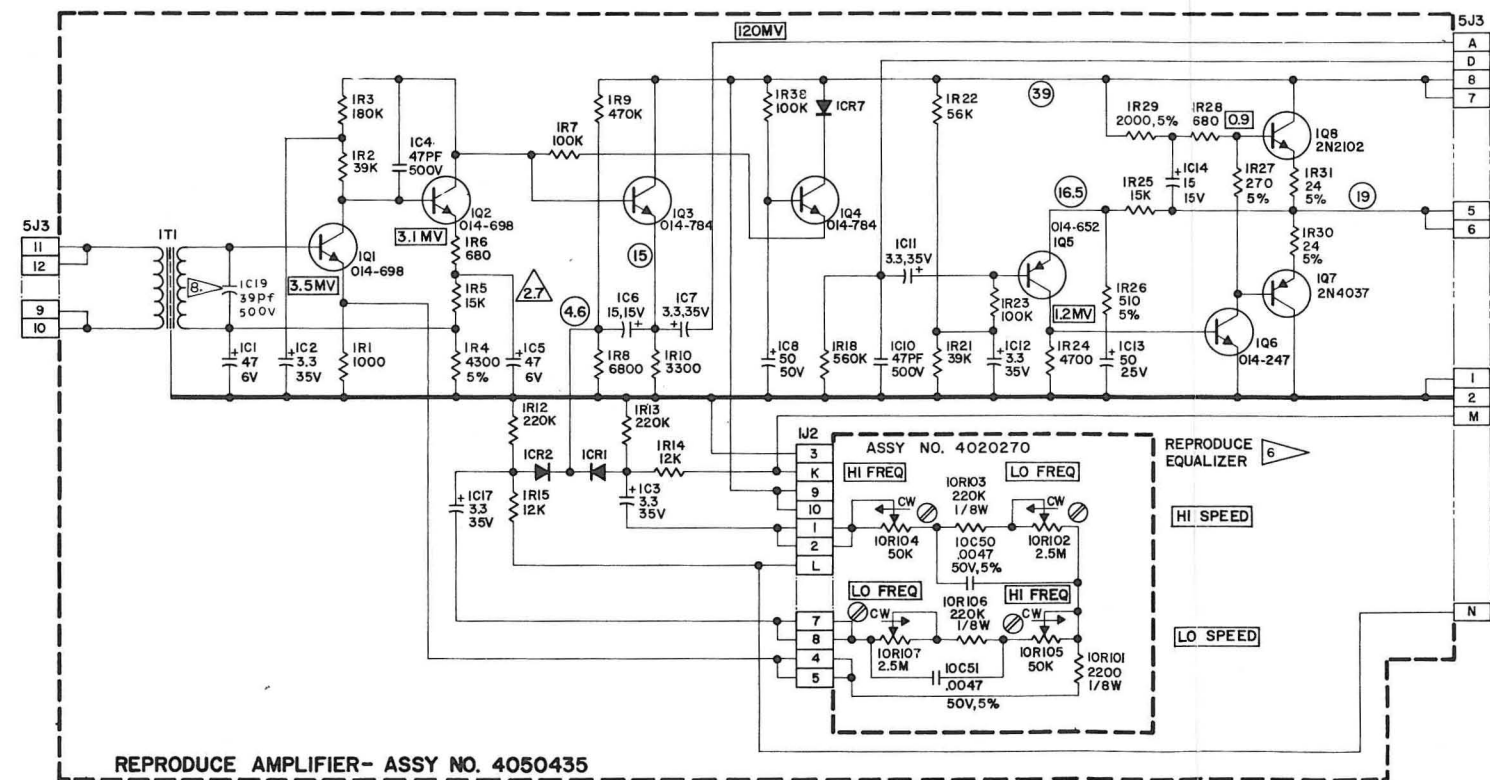
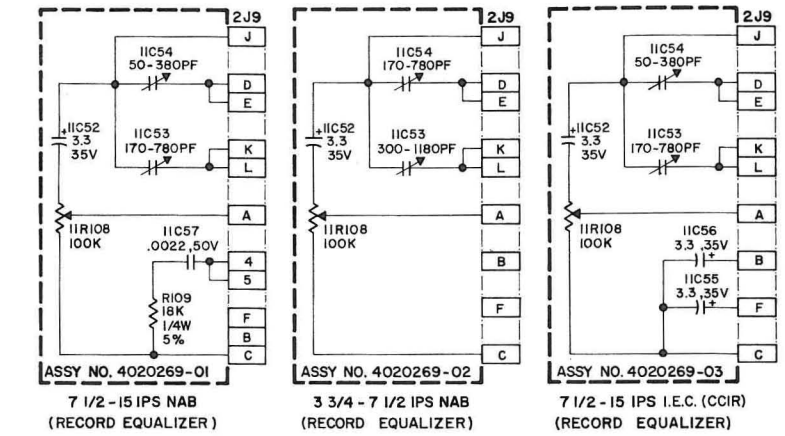
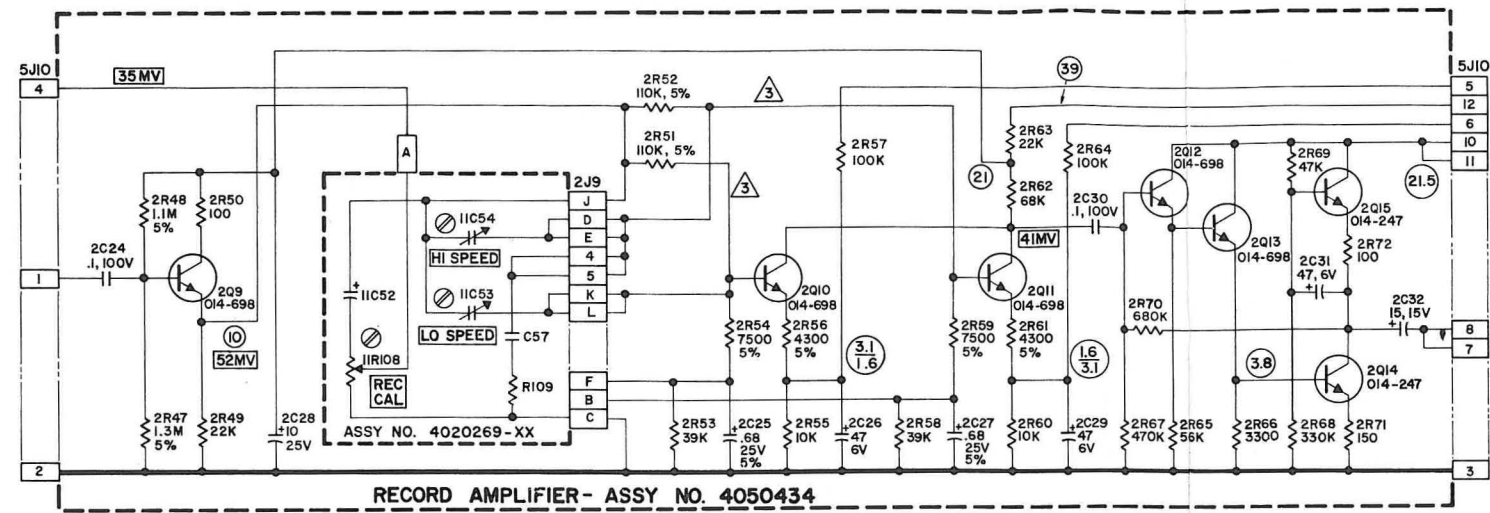

Fig. 6-24A. Schematic Diagram, Electronics

RECORD PRINTED WIRING BOARD ASSEMBLY

4050434 (Rev. E)

Item	-01	Description	Ampex Part No.
1	1	Printed wiring board	4500107-01
2	1	Front Plate, record module	4330262-01
3	2	Transistor, Silicon, CD38, Q14, 15	041-247
4	5	Transistor, Silicon, CD652, Q9-13	014-698
5	1	Capacitor, Electrolytic, 10 μ F, 25V	031-148
6	1	Capacitor, Tantalum, 15 μ F, 15V, 20%, C32	037-446
7	3	Capacitor, Tantalum, 47 μ F, 6V, 20%, C26, 29, 31	037-494
8	2	Capacitor, Tantalum, .68 μ F, 25V, 5%, C25, 27	037-495
9	2	Capacitor, Mylar, .1 μ F, 100V, 10%, C24, 30	055-106
10	2	Resistor, fixed, 4.3k ohm, 1/2W, 5%, R56, 61	041-012
11	2	Resistor, fixed, 110k ohm, 1/2w, 5%, R51, 52	041-024
12	2	Resistor, fixed, 100 ohm, 1/2W, 10%, R50, 72	041-038
13	1	Resistor, Fixed, 3.3k ohm, 1/2W, 10%, R66	041-054
14	2	Resistor, fixed, 10k ohm, 1/2W, 10%, R55, 60	041-060
15	2	Resistor, fixed, 22k ohm, 1/2W, 10%, R49, 63	041-064
16	2	Resistor, fixed, 39k ohm, 1/2W, 10%, R53, 58	041-067
17	1	Resistor, fixed, 47k ohm, 1/2w, 10%, R69	041-068
18	1	Resistor, fixed, 56k ohm, 1/2W, 10%, R65	041-069
19	1	Resistor, fixed, 68k ohm, 1/2W, 10%, R62	041-070
20	2	Resistor, fixed, 100k ohm, 1/2W, 10%, R57, 64	041-072
21	1	Resistor, fixed, 330k ohm, 1/2W, 10%, R68	041-078
22	1	Resistor, fixed, 470k ohm, 1/2W, 10%, R67	041-080
23	1	Resistor, fixed, 680k ohm, 1/2W, 10%, R70	041-082
24	1	Resistor, fixed, 150 ohm, 1/2W, 10%, R71	041-241
25	2	Resistor, fixed, 7.5k ohm, 1/2W, 5%, R54, 59	041-361
26	1	Resistor, fixed, 1.3 megohm, 1/2W, 5%, R47	041-377
27	1	Resistor, fixed, 1.1 megohm, 1/2W, 5%, R48	041-898
29	2	Transistor, pad	280-131
30	2	Screw, sem, pan head, 4-40 x 1/4	475-006
31	2	Washer, flat #4	501-008
32	1	Connector, assembly, 10 pin, J9	4030270-01
33	ref	Schematic	4840169
34	1	Label, record module	4110270-01



NOTES:
SEE SHEET 1.

Fig. 6-24B. Schematic Diagram, Electronics

REPRODUCE AMPLIFIER PRINTED WIRING ASSEMBLY

CATALOG NO. 4050435

SHEET 1 OF 2

NHA 4020260

ITEM NO.	AMPEX PART NO.	VENDOR OR MIL. NO.	SCHEMATIC REFERENCE	PART DESCRIPTION	QUANTITY REQUIRED PER VERSION						
					-03	-05					
2	4030270-02		J2	CONNECTOR ASSEMBLY, 10 Contact	1	1					
4	4330263-01			FRONT PLATE, Reproduce Module	1	1					
5	4580199-01		T1	TRANSFORMER INPUT	1	1					
6	013-599		CR1, 2, 7	DIODE	3	3					
7	014-247		Q6	TRANSISTOR, NPN	1	1					
8	014-652		Q5	TRANSISTOR	1	1					
9	014-784		Q3, 4	TRANSISTOR	2	2					
10	014-698		Q1, 2	TRANSISTOR, NPN	2	2					
11	014-706			HEATSINK, Transistor	2	2					
12	014-723	2N4037	Q7	TRANSISTOR	1	1					
13	014-329	2N2102	Q8	TRANSISTOR	1	1					
14	031-187		C8	CAPACITOR, Electrolytic, 50MF, 50V	1	1					
15	031-190		C13	CAPACITOR, Electrolytic, 50MF, 25V	1	1					
16	034-181		C4, 10	CAPACITOR, Mica, 47PF, 500V, 5%	2	2					
17	037-654		C2, 3, 7, 11, 12, 17	CAPACITOR, Tantalum, 3.3MF, 35V, 20%	6	6					
18	037-446		C6, 14	CAPACITOR, Tantalum, 15MF, 15V, 20%	2	2					
19	037-494		C1, 5	CAPACITOR, Tantalum, 47MF, 6V, 20%	2	2					
20	041-012		R4	RESISTOR, Composition, 4.3K ohm, 1/2W, 5%	1	1					
21	041-533		R30, 31	RESISTOR, Fixed, 24 ohm, 1/2W, 5%	2	2					
22	041-273		R27	RESISTOR, Fixed, 270 ohm, 1/2W, 5%	1	1					
23	041-046		R6, 28	RESISTOR, Fixed, 680 ohm, 1/2W, 10%	2	2					
24	041-048		R1	RESISTOR, Fixed, 1K ohm, 1/2W, 10%	1	1					
25	041-010		R29	RESISTOR, Fixed, 2.0K ohm, 1/2W, 5%	1	1					
26	041-054		R10	RESISTOR, Fixed, 3.3K ohm, 1/2W, 10%	1	1					
27	041-056		R24	RESISTOR, Fixed, 4.7K ohm, 1/2W, 10%	1	1					
28	041-058		R8	RESISTOR, Fixed, 6.8K ohm, 1/2W, 10%	1	1					
29	041-061		R14, 15	RESISTOR, Fixed, 12K ohm, 1/2W, 10%	2	2					
30	041-062		R5, 25	RESISTOR, Fixed, 15K ohm, 1/2W, 10%	2	2					
31	041-067		R2, 21	RESISTOR, Fixed, 39K ohm, 1/2W, 10%	2	2					
32	041-069		R22	RESISTOR, Fixed, 56K ohm, 1/2W, 10%	1	1					
33	041-072		R7, 23, 38	RESISTOR, Fixed, 100K ohm, 1/2W, 10%	3	3					
34	041-076		R12, 13	RESISTOR, Fixed, 220K ohm, 1/2W, 10%	2	2					
35	041-075		R3	RESISTOR, Fixed, 180K ohm, 1/2W, 10%	1	1					
36	041-080		R9	RESISTOR, Fixed, 470K ohm, 1/2W, 10%	1	1					
37	041-081		R18	RESISTOR, Fixed, 560K ohm, 1/2W, 10%	1	1					

4050435N

REPRODUCE AMPLIFIER PRINTED WIRING ASSEMBLY

CATALOG NO. 4050435

SHEET 2 OF 2

NHA 4020260

ITEM NO.	AMPEX PART NO.	VENDOR OR MIL. NO.	SCHEMATIC REFERENCE	PART DESCRIPTION	QUANTITY REQUIRED PER VERSION						
					-03	-05					
38	041-404		R26	RESISTOR, Composition, 510 ohm, 1/2W, 5%	1	1					
40	280-131			TRANSISTOR, Pad, .200 diameter	3	3					
43	034-180		C19	CAPACITOR, Mica, 500V, 39PF, 5%	-	1					
80	4840209			SCHEMATIC	-	REF					
82	4840169			SCHEMATIC	REF	-					

4050435N

AUG. 1971

6-32A/B

BIAS AMPLIFIER PRINTED WIRING BOARD ASSEMBLY
4050433 (Rev. G)

Item	-05	Description	Ampex Part No.
1	1	Bias Amplifier Printed Wiring Board	4500106-01
2	1	B as Equalization Bracket	4040972-01
3	1	Bias Module Label	4110269-01
4	1	Bias Module Front Plate	4330261-01
5	1	Pot, bias calibrate, 750 ohm, R44	4520154-01
6	1	Pot, bias adjust, 25k ohm, R80	4520145-20
7	2	Coil, oscillator, T3,4	4580123-01
18	2	Transistor, 2N2102, Q16,17	014-329
19	2	Transistor, NPN, Q18,19	014-653
20	1	Capacitor, electrolytic, 50mFd, 25V, C44	031-190
21	1	Capacitor, Mica, 2500pF, 500V, 5%, C42	034-994
22	1	Capacitor, Mica, 5000pF, 300V, 5%, C45	034-960
24	2	Resistor, 1 megohm, 1/2W, 10%, R90,91	041-031
25	1	Resistor, 22 ohm, 1/2W, 10%, R87	041-033
26	1	Resistor, 51 ohm, 1/2W, 5%, R83	041-345
27	1	Resistor, fixed, 1.6k ohm, 1W, 5%, R86	041-353
28	2	Resistor, 3k ohm, 1/2W, 5%, R84, 85	041-475
29	2	Resistor, 20k ohm, 1/2W, 5%, R88,89	041-529
30	2	Capacitor, mylar, .1mFd, 100V, 10%, C41,43	055-106
31	1	Resistor, wirewound 180 ohm, 5W, 5%, R82	059-017
32	2	Transistor, pad, .200 diameter	280-131
33	2	Screw, 4-40 x 1/4, pan head	475-006
34	1	Nut, hex, 1/4-32	492-046
35	1	Nut, hex, 3/8-32	492-095
36	4	Washer, flat, #4	501-008
37	1	Washer, lock, 1/4"	502-028
38	1	Washer, flat internal tooth, #12	502-059
39	1	Washer, flat, internal tooth, 3/8	502-083
42	1	Capacitor, mica, 620pF, 500V, 5%, C39	034-928
43	2	Screw, 4-40 x 5/16, pan head, sen	475-007
44	1	Capacitor, variable, 1,400-3,055pF, 250V, C40	038-011

RECORD EQUALIZER PRINTED WIRING ASSEMBLY

4020269

(Revision D)

(See Fig. 6-24)

Ref.	-01	-02	Description	Ampex Part No.
			Printed Wiring Board	4500109-02
R108	1	1	Resistor, variable, 100k ohm	4250153-01
C54	1	-	Capacitor Trimmer, 50-380pF	4540314-02
C53	1	-	Capacitor Trimmer, 170-780pF	4540314-03
C54	-	1	Capacitor Trimmer 170-780pF	4540314-03
C53	-	1	Capacitor Trimmer, 300-1180pF	4540314-04
C52	1	1	Capacitor, tantalum, 3.3 μ F, 35V, 20%	037-654
	ref	ref	Schematic	4840169
C57	1	-	Capacitor, mylar, .0022 μ F, 50V, 10%	055-164
R109	1	-	Resistor, fixed, 18k ohm, 1/4W, 5%	041-436
4020269C				

REPRODUCE EQUALIZER PRINTED WIRING ASSEMBLY

4020270

(Revision C)

(See Figs. 6-24 and 6-25)

Ref.	-01	Description	Ampex Part No.
		Printed Wiring Board, reproduce equalizer	4500110-01
R104,	1		
R105,	2	Potentiometer, 30k ohm	4520152-01
R102,			
R107,	2	Potentiometer, 2.5 megohm	4520152-02
R103,			
R106,	2	Resistor, 220k ohm, 1/8W, 10%	049-528
R101	1	Resistor, 2.2k ohm, 1/8W, 10%	049-527
C50,			
C51	2	Capacitor, .0047mFd, mylar	055-222
	ref	Schematic	4840169

4020270C

REPRODUCE MODULE

CATALOG NO. 4020150

SHEET 1 OF 2

NHA 4010141-44

ITEM NO.	AMPEX PART NO.	VENDOR OR MIL. NO.	SCHEMATIC REFERENCE	PART DESCRIPTION	QUANTITY REQUIRED PER VERSION						
					-03	-05					
1	4030269-03		J3	CONNECTOR ASSEMBLY, 12 Contact	1	1					
2	4050087-01			CABLE ASSEMBLY, Interconnecting	1	1					
3	4010435-03			PRINTED WIRING BOARD, Reproduce Amplifier	1	-					
4	4170284-01			LABEL, Module Front	1	1					
5	4170285-01			LABEL, Module Rear	1	1					
6	4260096-01			BRACKET, Capacitor Mounting	1	1					
7	4290655-01			CHASSIS, Module	1	1					
8	4290656-02			COVER, Module	1	1					
9	4520151-01		R11	POTENTIOMETER, 50K	1	1					
10	4550147-05		C9	CAPACITOR, Electrolytic 35/35/100/100	1	1					
11	4580193-01		T2	TRANSFORMER, Output	1	1					
12	4620172-10		S3	SWITCH, Low End Equalization	1	1					
13	4700440-00 -99			WIRE, #22 AWG, bunch tinned	A/R	A/R					
14	4700474-01			CABLE, Shielded	A/R	A/R					
15	034-177		C17	CAPACITOR, 100PF, 500V, 5%	1	1					
16	013-599		CR3,4	DIODE, Silicon, switching	2	2					
17	031-134		C16	CAPACITOR, 500MF, 50V	1	1					
18	031-126		C15	CAPACITOR, 250MF, 50V	1	1					
19	041-046		R33	RESISTOR, 680 ohm, 1/2W, 10%	1	1					
20	041-060		R19,20	RESISTOR, 10K ohm, 1/2W, 10%	2	2					
21	041-062		R16,17	RESISTOR, 15K ohm, 1/2W, 10%	2	2					
22	143-008		J1	CONNECTOR, Receptacle, male, 3 contact	1	1					
23	147-999		J4	CONNECTOR, Audio Receptacle, 3 pin, XLR-3	1	1					
24	172-004			TERMINAL LUG, Lock, #4	1	1					
25	264-017			BUSHING, Strain Relief, black, nylon	1	1					
27	471-328			SCREW, 4-40 x 3/8, flat head, cross-recessed	2	2					
28	471-063			SCREW, 4-40 x 7/16, pan head, cross-recessed	2	2					
30	476-057			SCREW, 4-40 x 5/16, hex washer head	4	4					
31	476-998			SCREW, 6 x 1/4, hex washer head	12	12					
32	492-095			NUT, 3/8-32	2	2					
33	496-004			NUT, 4-40, keps	2	2					
34	497-020			NUT, Speed Nut, type "U"	2	2					
35	501-008			WASHER, Flat, #4	1	1					
36	501-224			WASHER, 3/8, flat	2	2					
37	502-083			LOCKWASHER, 3/8, flat, internal tooth	3	3					

4020150K

REPRODUCE MODULE

CATALOG NO 4020150

SHEET 2 OF 2

NHA 4010141-44

ITEM NO.	AMPEX PART NO.	VENDOR OR MIL. NO.	SCHEMATIC REFERENCE	PART DESCRIPTION	QUANTITY REQUIRED PER VERSION						
					-03	-05					
38	4230133-02			GUIDE, Printed Wiring Board	2	2					
39	600-036			SLEEVING, #20, clear teflon	A/R	A/R					
40	615-002			WIRE, #22 AWG, bare	A/R	A/R					
41	030-001		C18	CAPACITOR, .02μF, 500V	1	1					
42	041-040		R34	RESISTOR, Fixed, 220 ohm, 1/2W, 10%	1	1					
43	148-015		J5	JACK, Phone with Hardware	1	1					
44	613-021			CABLE, Shielded & Jacketed, white, #26 AWG	A/R	A/R					
45	501-186			WASHER, #4, flat	2	2					
46	502-101			LOCKWASHER, #4	2	2					
48	4050435-07			PRINTED WIRING BOARD, Reproduce Amplifier	-	1					
50	6000035-02			LABEL, Identification	1	1					
81	4840265			SCHEMATIC	-	REF					
82	4840176			SCHEMATIC	REF	-					

4020150K

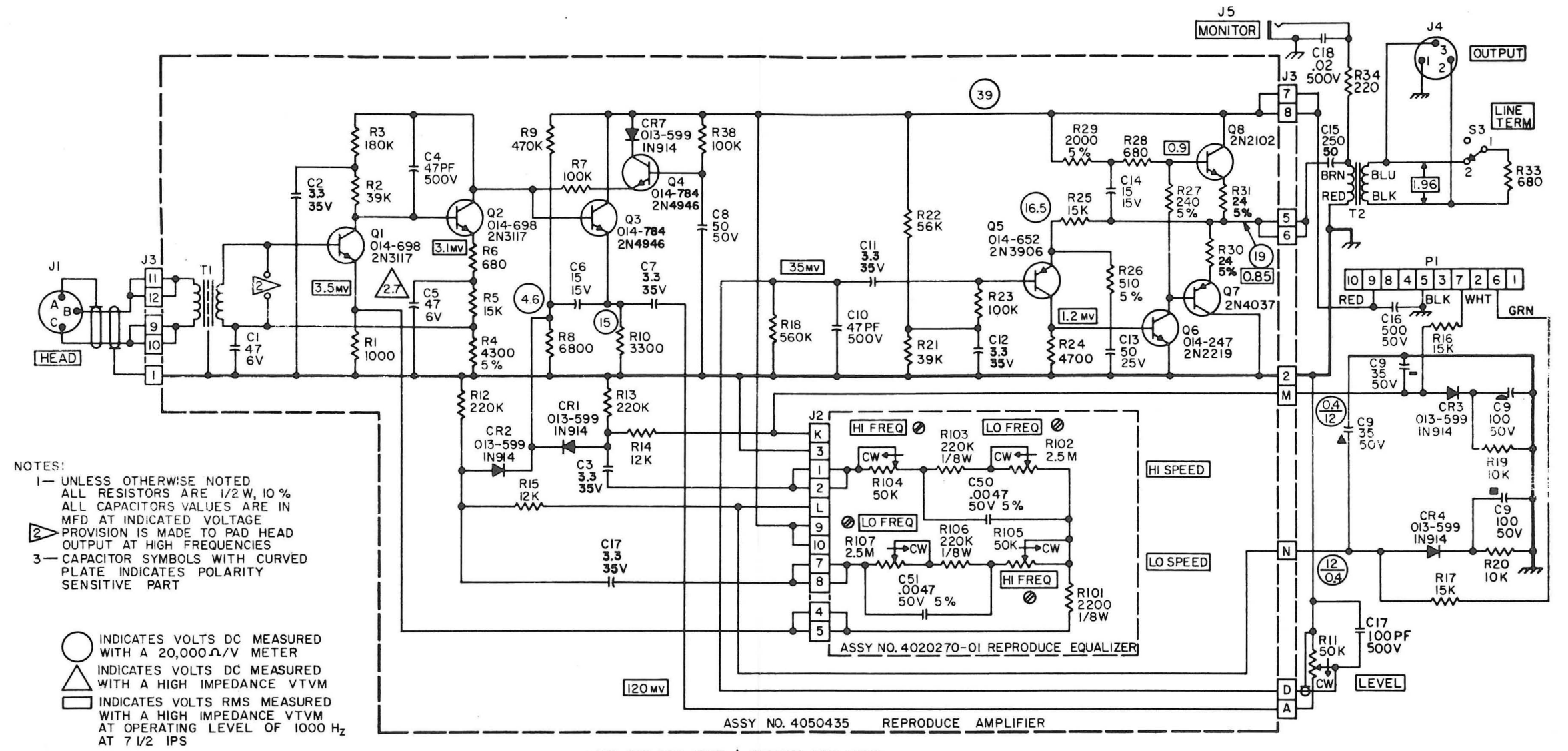

NOTES:
 1- UNLESS OTHERWISE NOTED ALL RESISTORS ARE 1/2 W, 10% ALL CAPACITORS VALUES ARE IN MFD AT INDICATED VOLTAGE
 2- PROVISION IS MADE TO PAD HEAD OUTPUT AT HIGH FREQUENCIES
 3- CAPACITOR SYMBOLS WITH CURVED PLATE INDICATES POLARITY SENSITIVE PART

○ INDICATES VOLTS DC MEASURED WITH A 20,000 Ω/V METER
 △ INDICATES VOLTS DC MEASURED WITH A HIGH IMPEDANCE VTVM
 □ INDICATES VOLTS RMS MEASURED WITH A HIGH IMPEDANCE VTVM AT OPERATING LEVEL OF 1000 Hz AT 7 1/2 IPS

LAST REF DES USED	REF DES NOT USED
R34	CR5,6
R107	
C18	
C51	
J5	
CR7	
T2	
Q8	
PI	

Fig. 6-25. Electronics Schematic, Reproduce-only

REAR PANEL ASSEMBLY

CATALOG NO. 4050439

SHEET 1 OF 1

NHA 4020260

ITEM NO.	AMPEX PART NO.	VENDOR OR MIL. NO.	SCHEMATIC REFERENCE	PART DESCRIPTION	QUANTITY REQUIRED PER VERSION					
					-06	-07				
1	4040957-03			PANEL, Rear	1	-				
2	4520154-02		R43	POTENTIOMETER, 5K ohm	1	1				
3	031-309		C23	CAPACITOR, Electrolytic, 4MF, 25V	1	1				
4	038-011		C18	CAPACITOR, Variable, 1400-3055PF	1	1				
5	041-065		R45	RESISTOR, Fixed, 27K ohm, 1/2W, 10%	1	1				
6	540-030		L1	CHOKER, 330MH, 5%	1	1				
7	070-026		F1	FUSE, Slo-Blo, 0.5 amp. 125V	1	1				
8	085-001			FUSE HOLDER	1	1				
9	122-016		S3	SWITCH, Rotary, 1 Pole, 2 throw	1	1				
10	143-008		J1	CONNECTOR, Receptacle, 3 contact, male	1	1				
11	143-009		J6	CONNECTOR, Receptacle, 2 contact, male	1	1				
12	143-010		J12	CONNECTOR, Receptacle, 1 contact, male	1	1				
13	146-998		J7	CONNECTOR, Audio Receptacle, 3 socket	1	1				
14	147-999		J5	CONNECTOR, Audio Receptacle, 3 pin	1	1				
17	230-008			KNOB, Black w/Pointer	1	1				
29	030-001		C36,37	CAPACITOR, Ceramic, .02μF, 500V	2	2				
31	056-021		C38	CAPACITOR, Mica, 1500PF, 500V	1	-				
32	041-257		R77	RESISTOR, Composition, 180 ohm, 1/2W, 10%	1	1				
33	020-144		K1	RELAY, 24V, 650 ohm, 4P2T	1	1				
34	020-492			SPRING, Relay, holddown	1	1				
41	013-678		CR5,6,9,10	DIODE	3	4				
42	020-592		K2	RELAY, Reed, SPST	1	1				
44	041-034		R110	RESISTOR, 47 ohm, 1/2W, 10%	1	1				
48	4040957-04			PANEL, Rear	-	1				
49	014-247		Q20	TRANSISTOR	-	1				
50	034-056		C60	CAPACITOR, Mica, 390PF, 500V, 5%	-	1				
51	063-045		C19	CAPACITOR, Aluminum, 10μF, 50V	-	1				
55	041-477		R93	RESISTOR, Composition, 13K ohm, 1/2W, 5%	-	1				
56	041-546		R92	RESISTOR, Composition, 130K ohm, 1/2W, 5%	-	1				
57	013-450		VR1	DIODE, Zener, 10V	-	1				
58	034-386		C38	CAPACITOR, Mica, 910PF, 100V, 5%	-	1				
59	037-117		C58	CAPACITOR, Tantalum, 150μF, 30V, 20%	1	1				
60	041-046		R33	RESISTOR, Fixed, 680 ohm, 1/2W, 10%	1	1				

4050439S

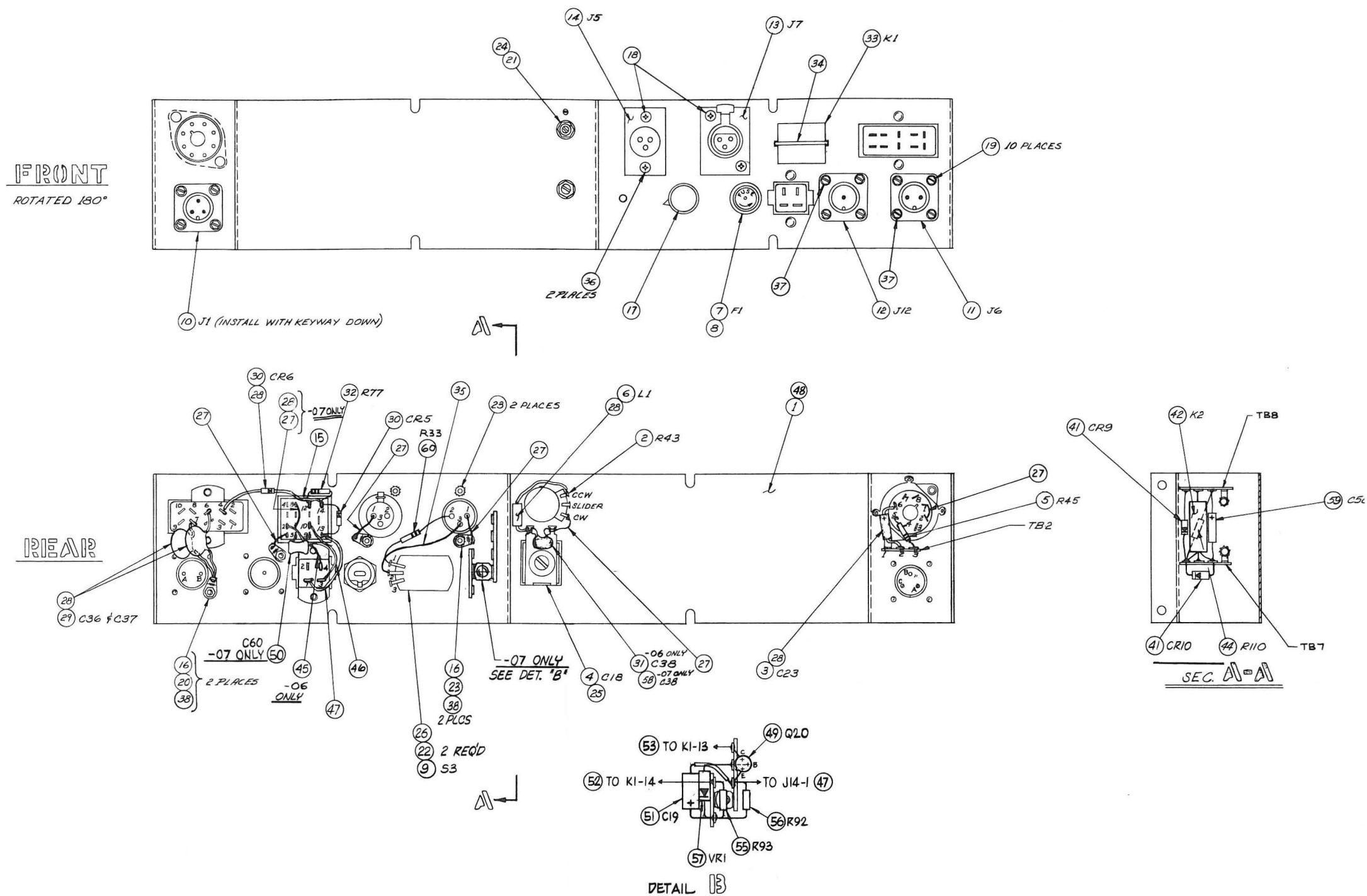

Fig. 6-26. Rear Panel Assembly

FRONT PANEL ASSEMBLY

CATALOG NO. 4050438

SHEET 1 OF 1

NHA 4020260

ITEM NO.	AMPEX PART NO.	VENDOR OR MIL. NO.	SCHEMATIC REFERENCE	PART DESCRIPTION	QUANTITY REQUIRED PER VERSION					
					-04					
1	4040956-02			PANEL, Backing	1					
2	4100102-02			KNOB, Key Tab	1					
5	4140020-02		M1	METER, VU	1					
6	4290638-01			PANEL, Facing	1					
8	4620198-01		S2	SWITCH, Lever	1					
9	6000005-20			KNOB, Pointer	1					
10	030-001		C16	CAPACITOR, .02MF, ceramic, 500V	1					
11	034-358		C35	CAPACITOR, 220PF, mica, 5%, 300V	1					
12	041-200		R75,76	RESISTOR, 560 ohm, 2W, 10%	2					
14	044-015		R46	RESISTOR, Variable, carbon, 2W, 100K ohm, 10%	1					
15	044-233		R11	RESISTOR, Variable, carbon, 2W, 10K ohm, 20%	1					
16	051-342		L2	CHOKE, 5MH	1					
17	132-098			SOCKET, Light	4					
18	132-099		T4	LIGHT, Indicator, amber	1					
19	132-100		T3	LIGHT, Indicator, red	1					
20	4610017-01		T1,T2	LIGHT, Indicator, clear	2					
21	148-015		J4	PHONE JACK	1					
22	4620049-02		S1	SWITCH, Selector	1					
24	435-069			RETAINER, C-Lite	2					
29	180-256		TB5	TERMINAL STRIP, A1,G,A1,A1,A1	1					
34	4260115-01			BRACKET, Meter Lamp	2					
35	435-144			CLIP, Lamp	2					
36	6000009-20			KNOB, Black Skirted	2					
37	4040350-02			RESET INDICATOR ASSEMBLY	2					
38	6000039-15			PLATE, Die Cast Trademark	1					
42	034-938		C59	CAPACITOR, Mica, 110PF, 500V, 5%	1					
43	180-026			TERMINAL STRIP, A1,D	1					
44	* 540-055		L3	INDUCTOR, 10MH, 10%	1					

4050438F

AUG. 1971

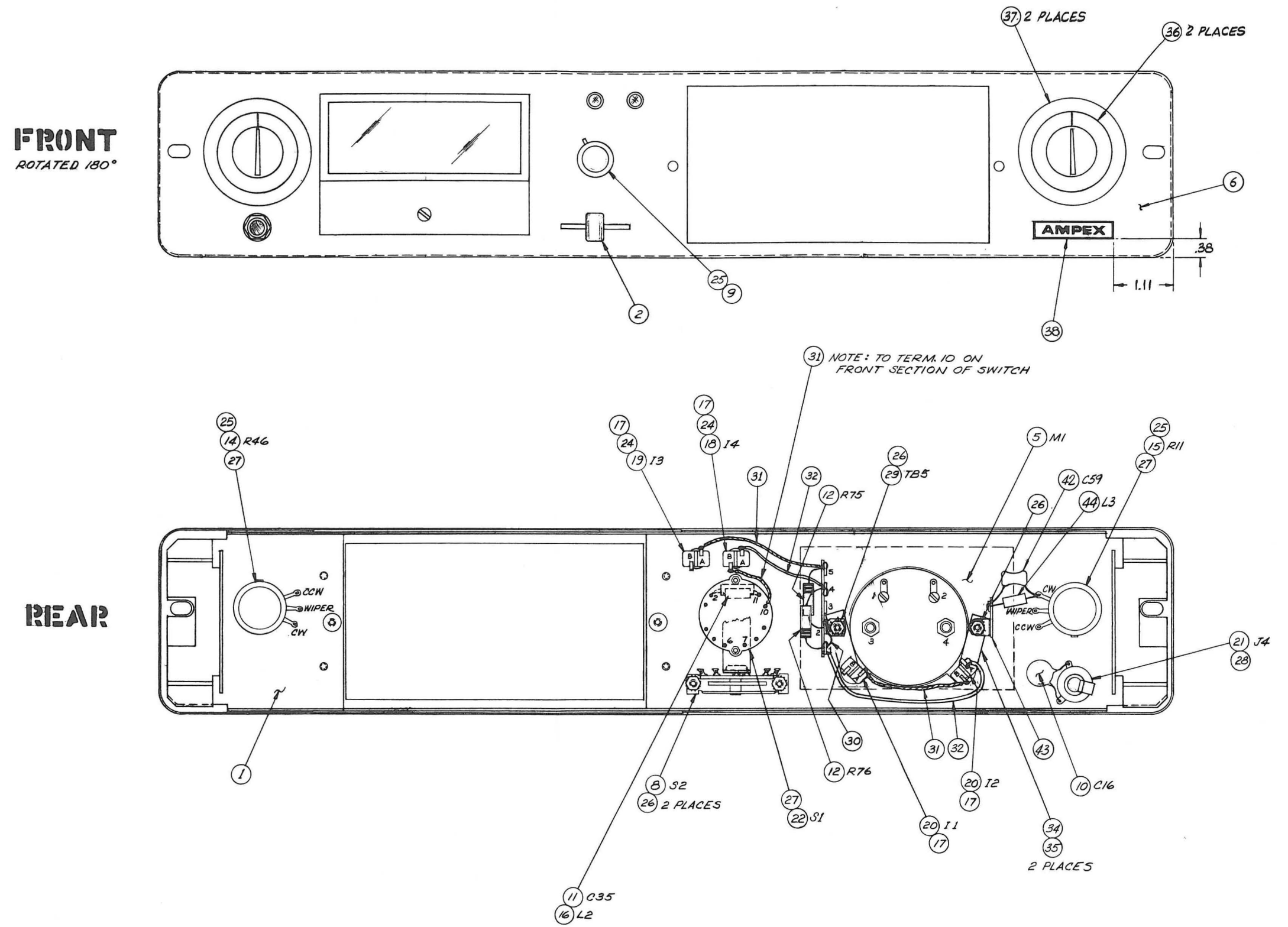
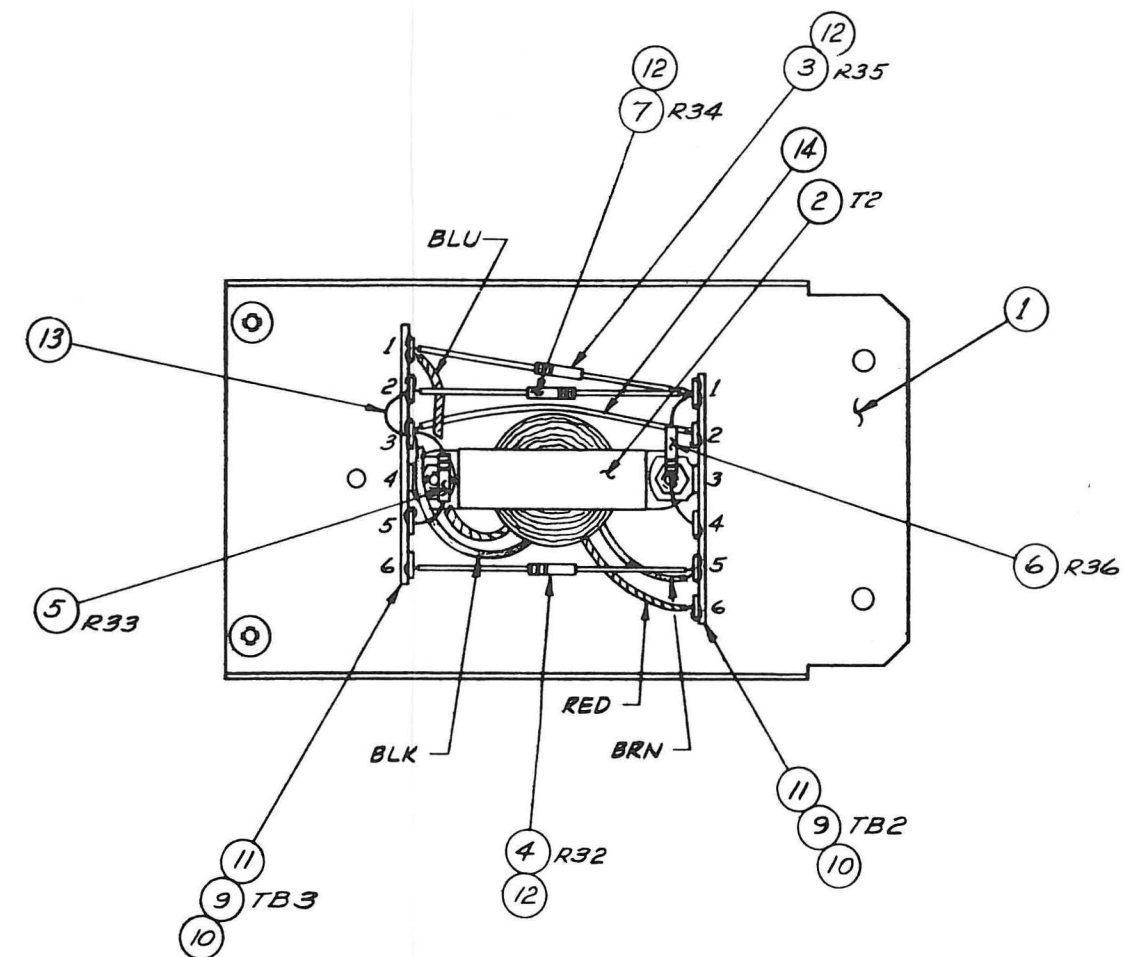

Fig. 6-27. Front Panel Assembly

RIGHT SIDE PANEL ASSEMBLY				CATALOG NO. 4050441		SHEET 1 OF 1		
				NHA 4020260				
ITEM NO.	AMPEX PART NO.	VENDOR OR MIL. NO.	SCHEMATIC REFERENCE	PART DESCRIPTION	QUANTITY REQUIRED PER VERSION			
					-03	-04		
1	4040958-01			PANEL, Right Side	1	1		
2	4580193-01		T2	TRANSFORMER, Output	1	1		
3	041-012		R35	RESISTOR, Composition, 4.3K ohm, 1/2W, 5%	1	1		
4	041-040		R32	RESISTOR, Fixed, 220 ohm, 1/2W, 10%	1	1		
6	041-316		R36	RESISTOR, Fixed, 2.4K ohm, 1/2W, 5%	1	1		
7	041-373		R34	RESISTOR, Composition, 9.1K ohm, 1/2W, 5%	1	1		
9	180-994		TB2,3	TIE POINT, A1, A1, G, A1, A1, A1	2	2		



4050441C

Fig. 6-28. Right Hand Panel, Electronics
6-38

CAPACITOR MOUNTING BRACKET ASSEMBLY				CATALOG NO. 4050440	SHEET 1 OF 1	
				NHA 4020260		
ITEM NO.	AMPEX PART NO.	VENDOR OR MIL. NO.	SCHEMATIC REFERENCE	PART DESCRIPTION	QUANTITY REQUIRED PER VERSION	
					-02	
1	4040964-01			BRACKET, Capacitor Mounting	1	
2	4550147-07		C33	CAPACITOR, 350,750,250MF/35,25,25V	1	
3	4550147-04		C34	CAPACITOR, 1500MF, 40V	1	
4	4550147-05		C9	CAPACITOR, 100,100,35,35MF/50V	1	
6	041-060		R19,20	RESISTOR, 10K ohm, 1/2W, 10%	2	
7	041-062		R16,17	RESISTOR, 15K ohm, 1/2W, 10%	2	
8	041-833		R73	RESISTOR, 750 ohm, 1W, 5%	1	
10	041-056		R78	RESISTOR, 4700 ohm, 1/2W, 10%	1	
11	013-678		CR3,4,8	DIODE	3	

4050440C

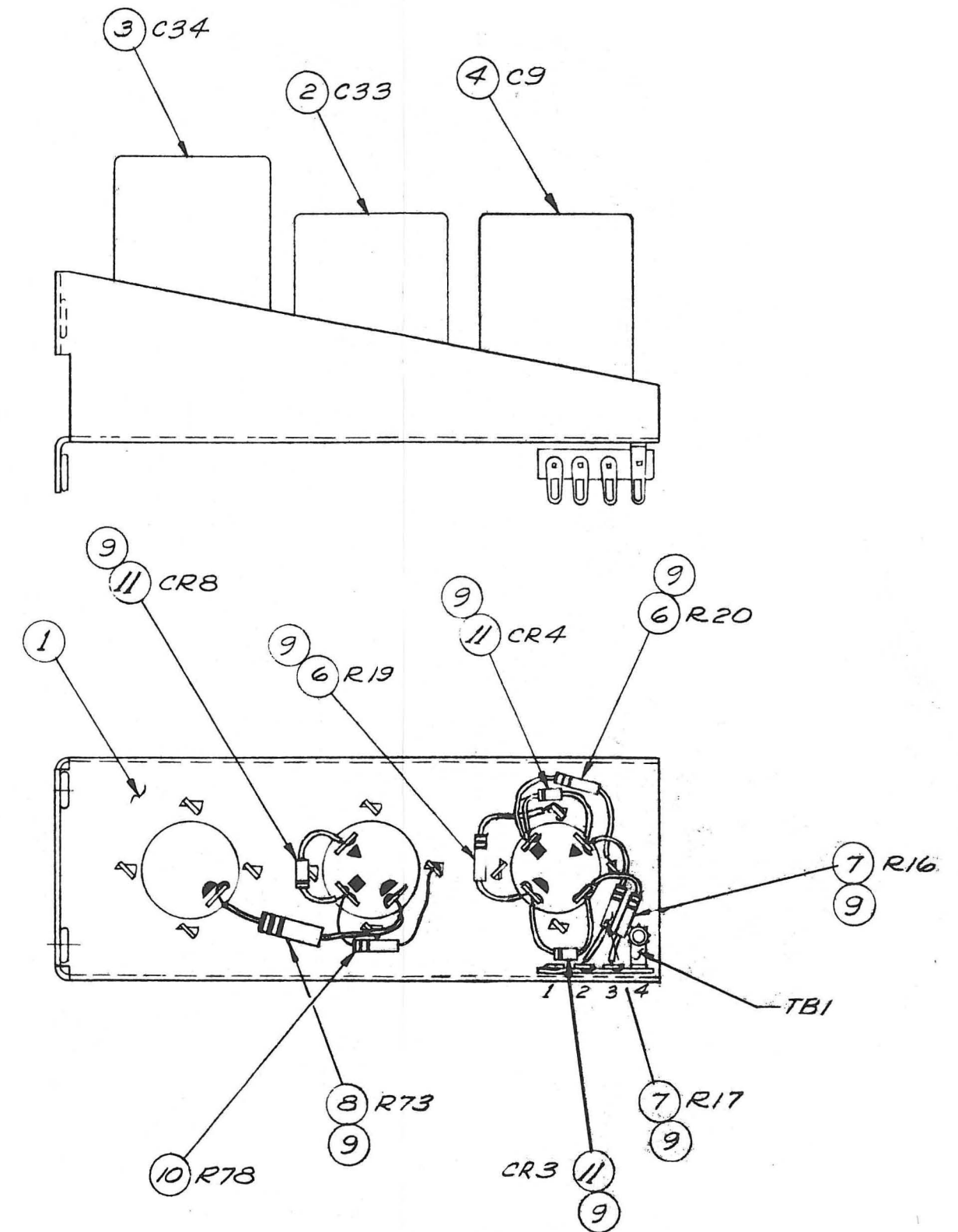

SECTION VI

ACCESSORIES AND MISCELLANEOUS

OPTIONAL ACCESSORY
 REMOTE CONTROL ASSEMBLY
 CATALOG NO. 4010080D
 (see Fig. 6-30)

Item	Qty	DESCRIPTION	Ampex Part No.
1	1	Panel, assembly	4040997-01
2	1	Base, assembly	4040999-01
3	3	Pushbutton, white (fast forward, rewind, edit)	4100183-01
4	1	Pushbutton, yellow (stop)	4100183-02
5	1	Pushbutton, red (record)	4100183-03
6	1	Escutcheon	4110274-01
7	3	Switch, pushbutton (fast forward, rewind, play)	4620144-10
8	2	Switch, pushbutton (stop, edit)	4620144-20
9	1	Switch, pushbutton (record)	4620144-30
10	3	Socket, light	132-098
11	1	Light, indicator, amber	132-099
12	1	Light, indicator, red	132-100
13	1	Light, indicator, green	060-338
14	3	Clip, lamp holder	435-069
17	3	Resistor, fixed, comp; 180 ohms, ±10%, 1/2w; RC20GF181K	041-257
18	1	Strain Relief	264-011
19	1	Cable, assembly, remote control (captive)	4050086-01
	1	Connector, plug, 12 pins, male	145-019
	25'	Cable, 12 conductor	617-090
22	1	Pushbutton, green (play)	4100183-04

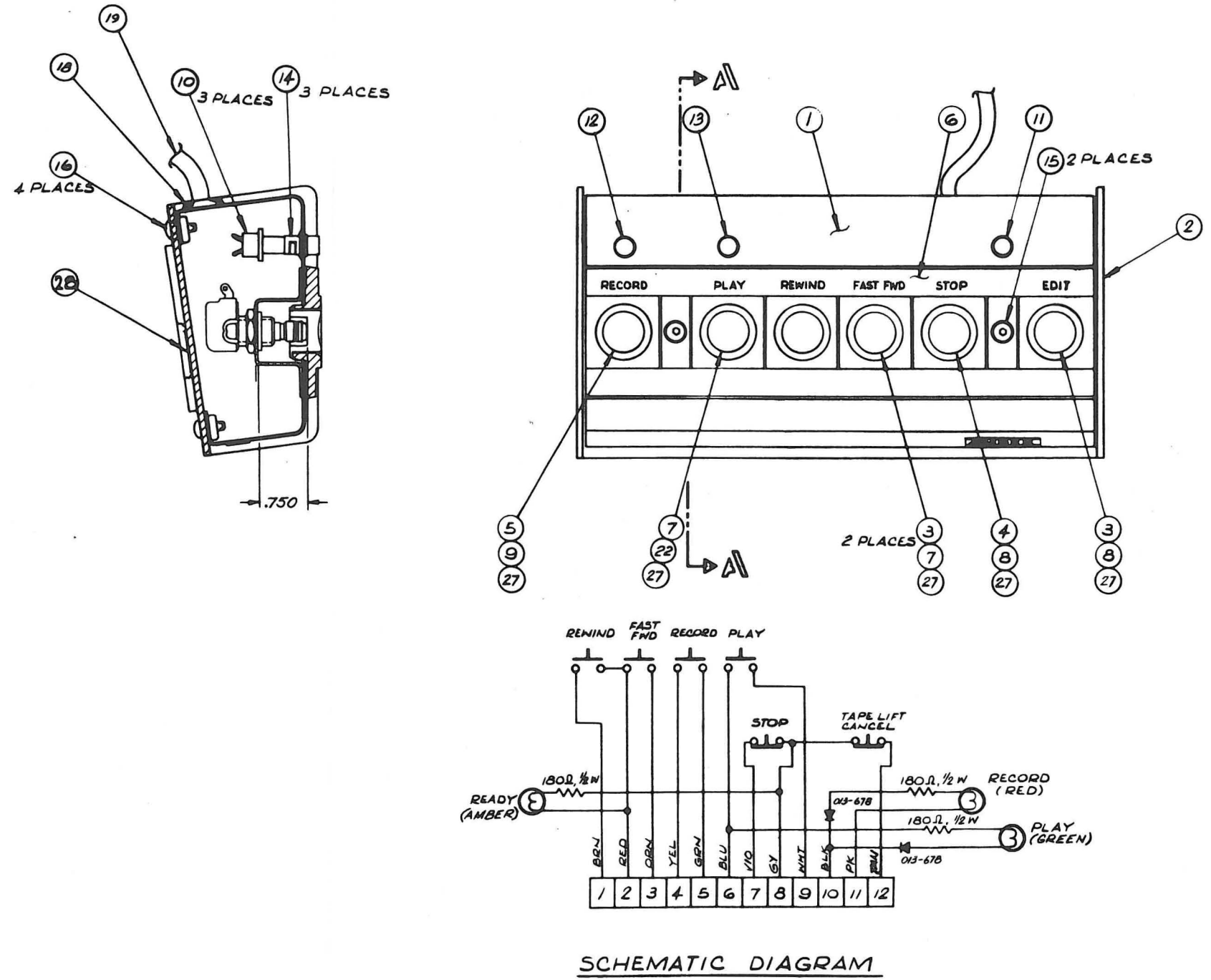
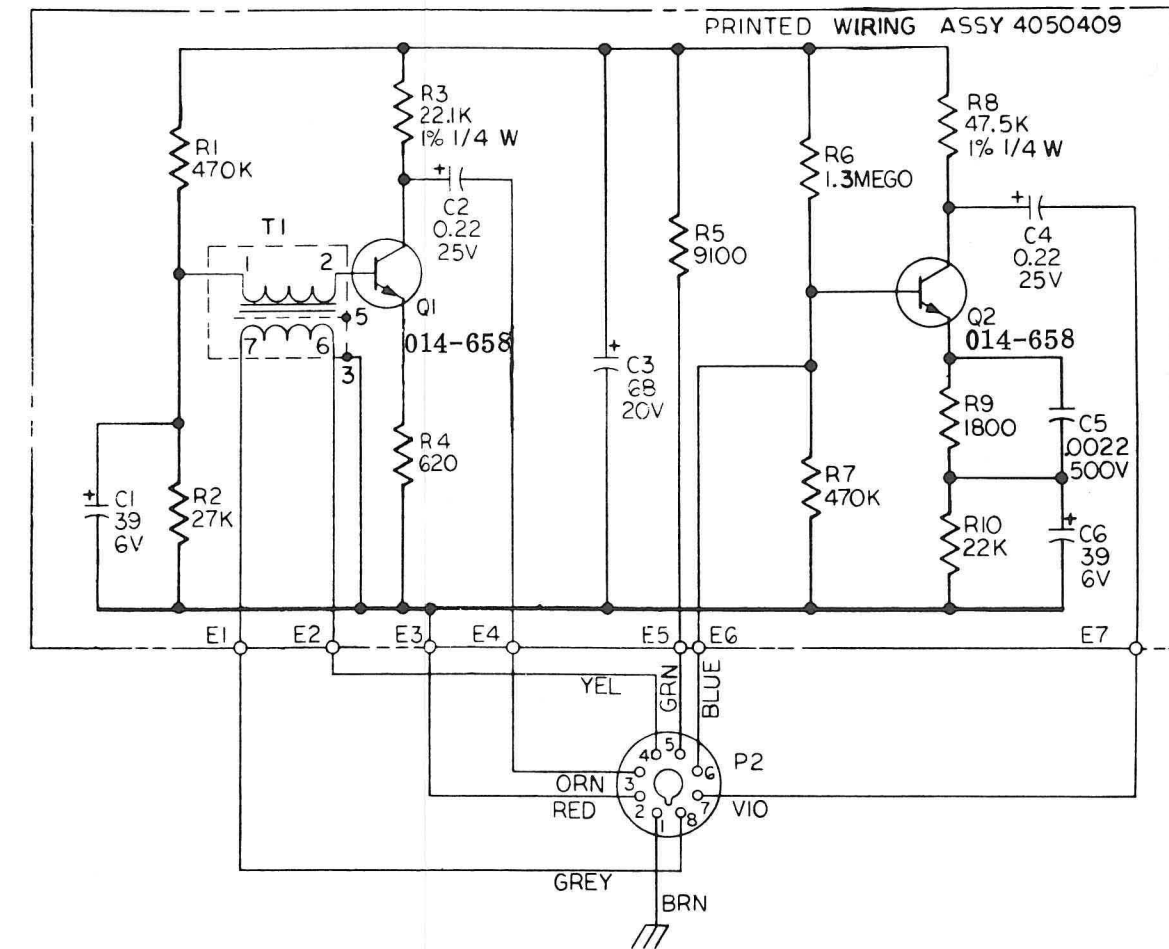
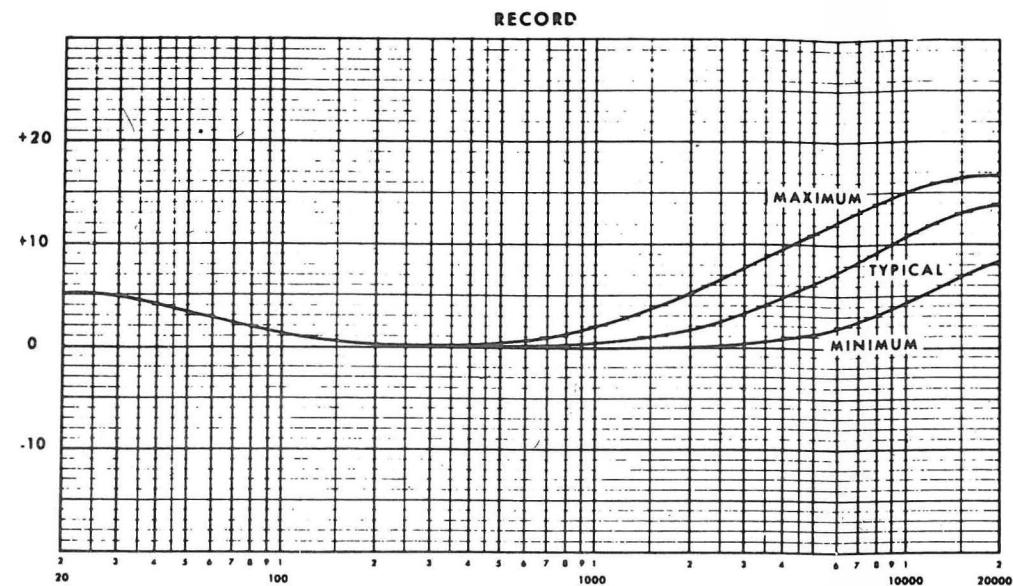

Fig. 6-30. Optional Remote Control

Ref.	Qty	DESCRIPTION	Ampex Part No.
	1	Printed Circuit Board, assembly	4050409-01
C1	2	Capacitor, tantalum; 39 mfd, ±20%, 6 vdcw	037-452
C2	2	Capacitor, tantalum; 0.22 mfd, ±20%, 25 vdcw	037-450
C3	1	Capacitor, tantalum; 68 mfd, ±20%, 20 vdcw	037-451
C4	-	Same as C2	
C5	1	Capacitor, ceramic disc; .0022 mfd, ±10%, 500 vdcw	030-102
C6	-	Same as C1	
Q1	2	Transistor, silicon; low noise, low level	014-698
Q2	-	Same as Q1	
R1	2	Resistor, fixed, comp; 470,000 ohms, ±5%, 1/2w; RC20GF474J	041-029
R2	1	Resistor, fixed, comp; 27,000 ohms, ±5%, 1/2w; RC20GF273J	041-015
R3	1	Resistor, metal film; 22,100 ohms, ±1%, 1/4w	057-208
R4	1	Resistor, fixed, comp; 620 ohms, ±5%, 1/2w; RC20GF621J	041-006
R5	1	Resistor, fixed, comp; 9,100 ohms, ±5%, 1/2w; RC20GF912J	041-373
R6	1	Resistor, fixed, comp; 1.3 meg ohms, ±5%, 1/2w; RC20GF135J	041-377
R7	-	Same as R1	
R8	1	Resistor, metal film; 47,500 ohms, ±1%, 1/4w	042-482
R9	1	Resistor, fixed, comp; 1,800 ohms, ±5%, 1/2w; RC20GF182J	041-009
R10	1	Resistor, fixed, comp; 22,000 ohms, ±5%, 1/2w; RC20GF223J	041-016
T1	1	Transformer, microphone	4580197-01
	2	Sockets, transistors	150-103
	1	Can, plug-in	4290201-10





3 3/4 ips (120 usec)

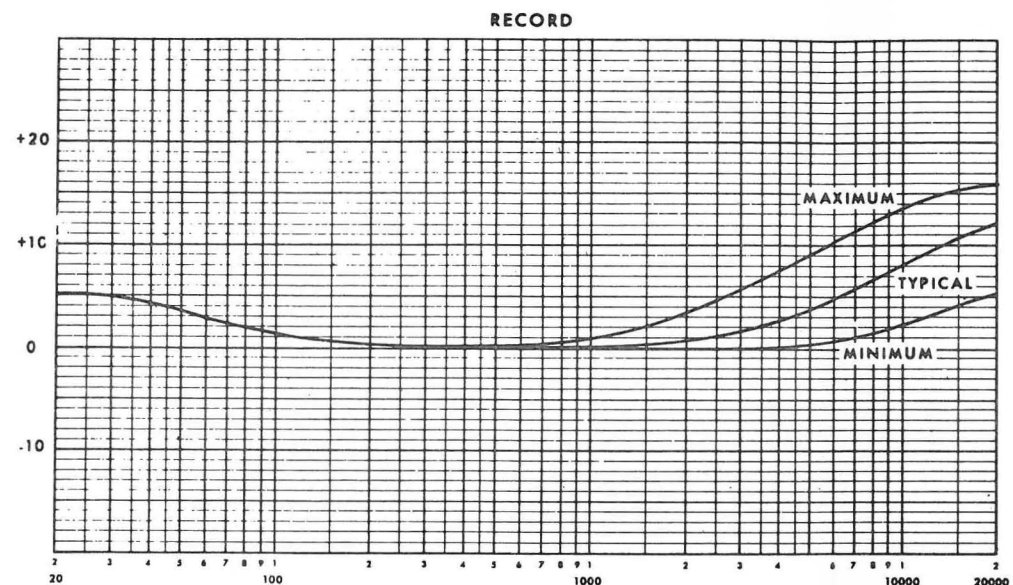
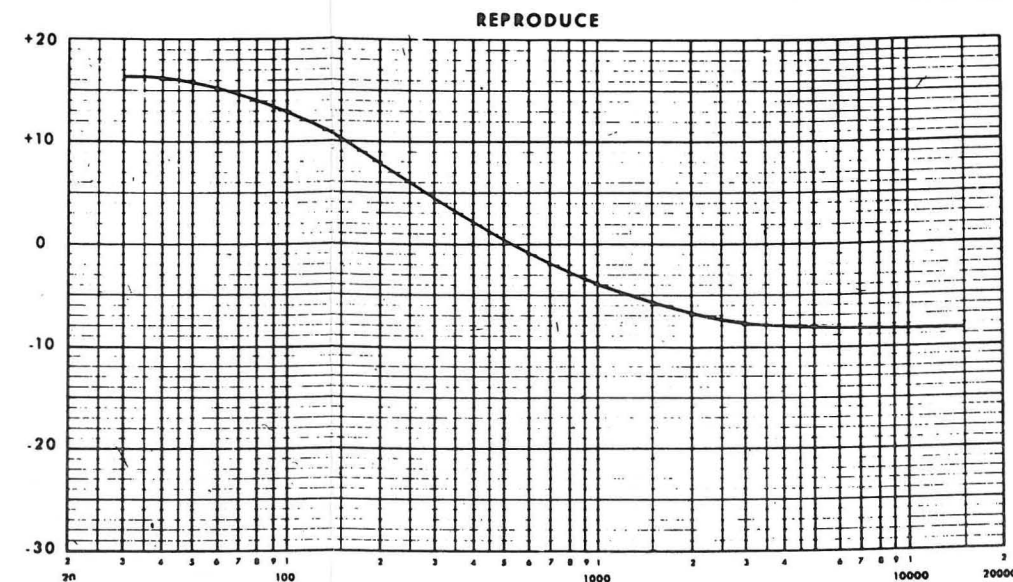

7 1/2 ips NAB

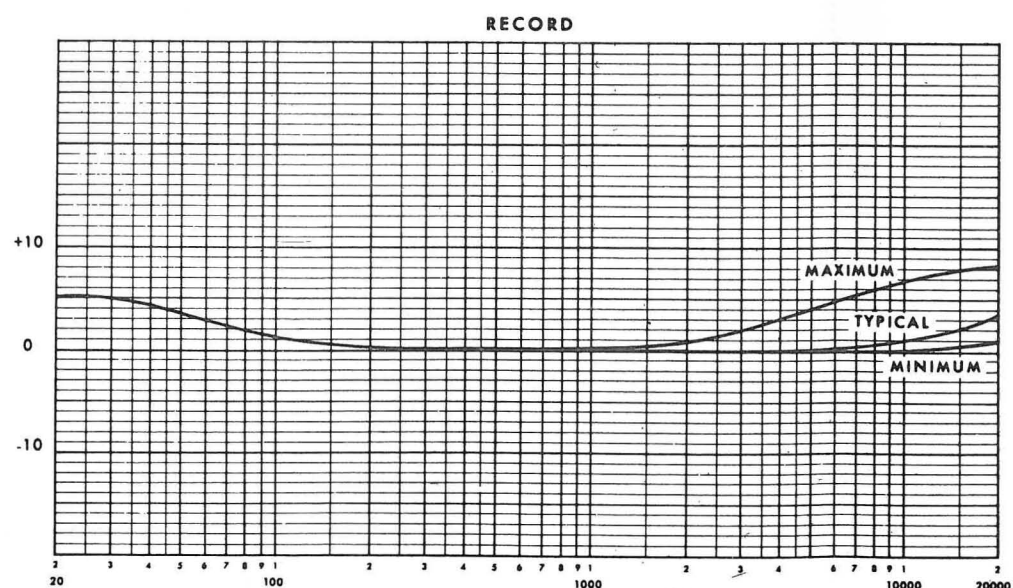
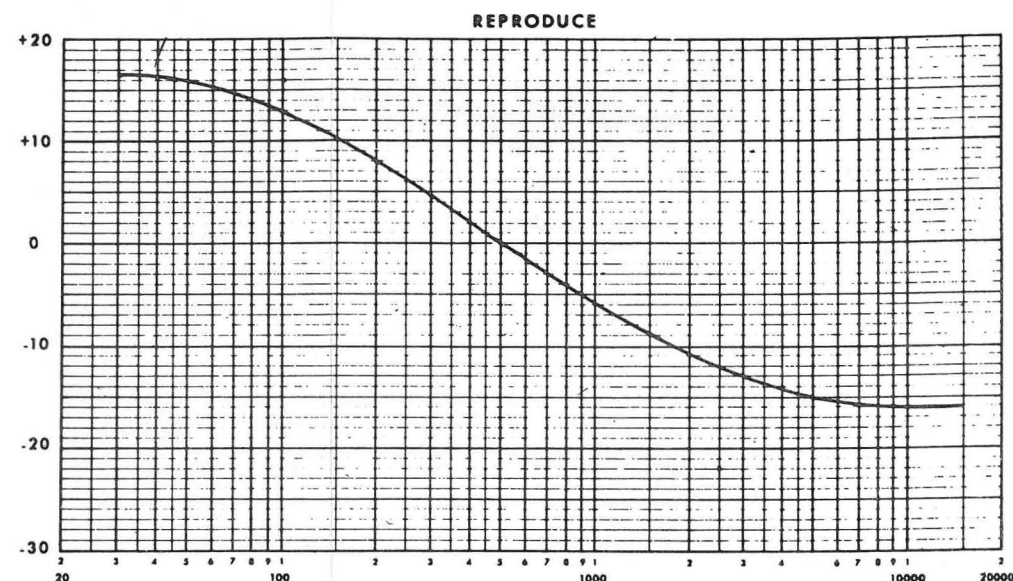

15 ips NAB

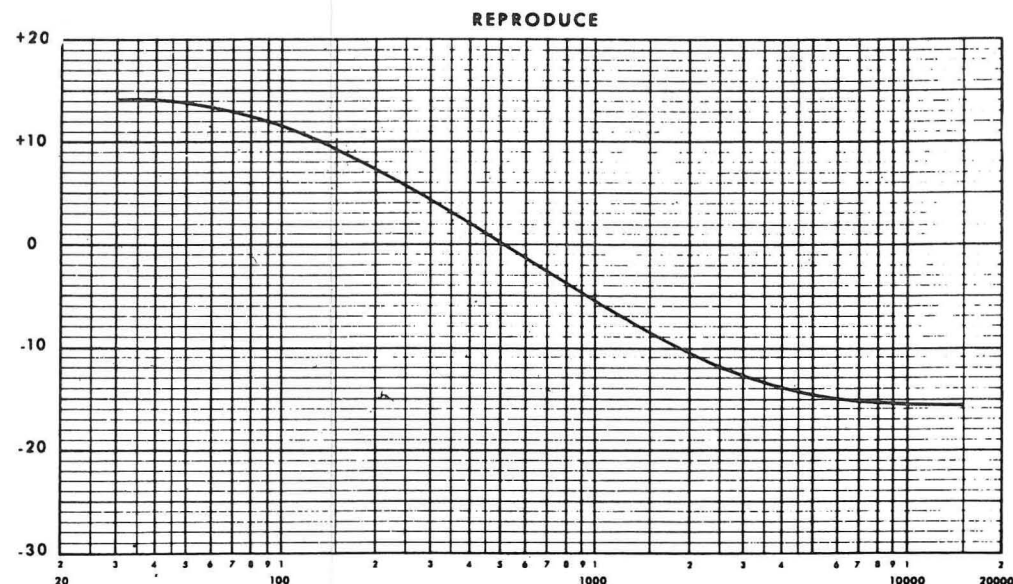
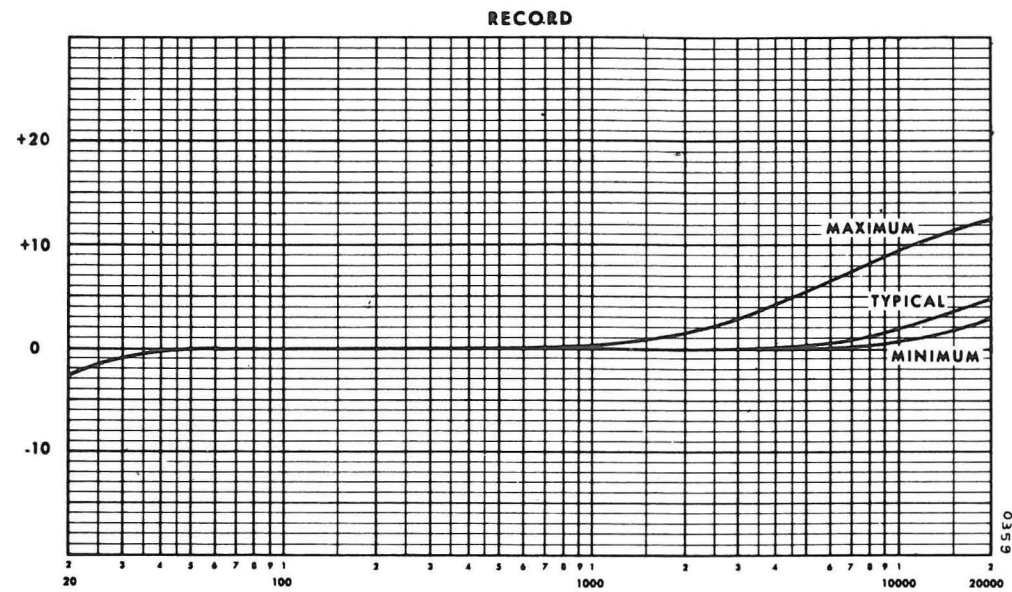
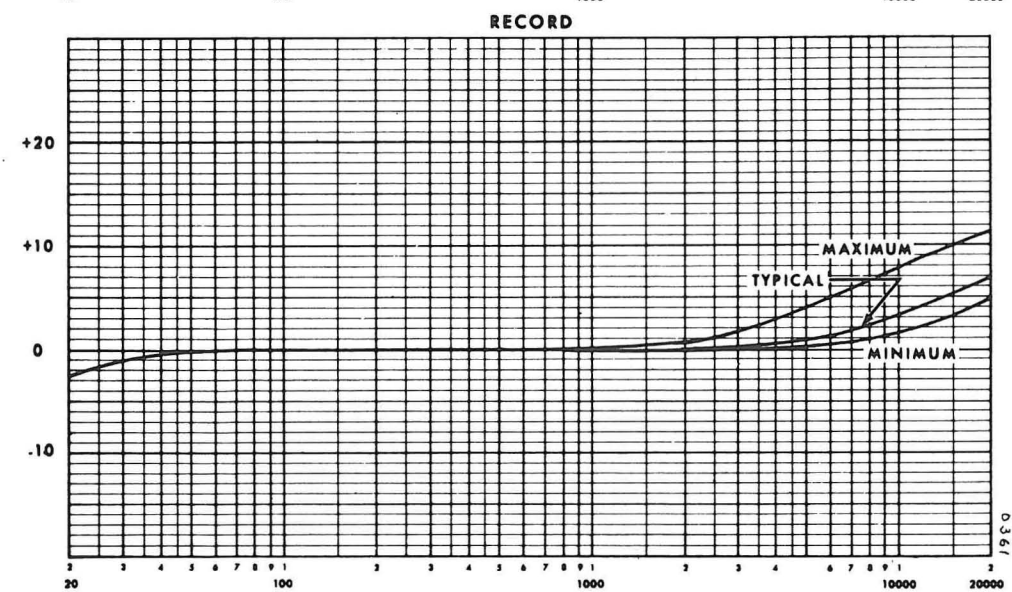
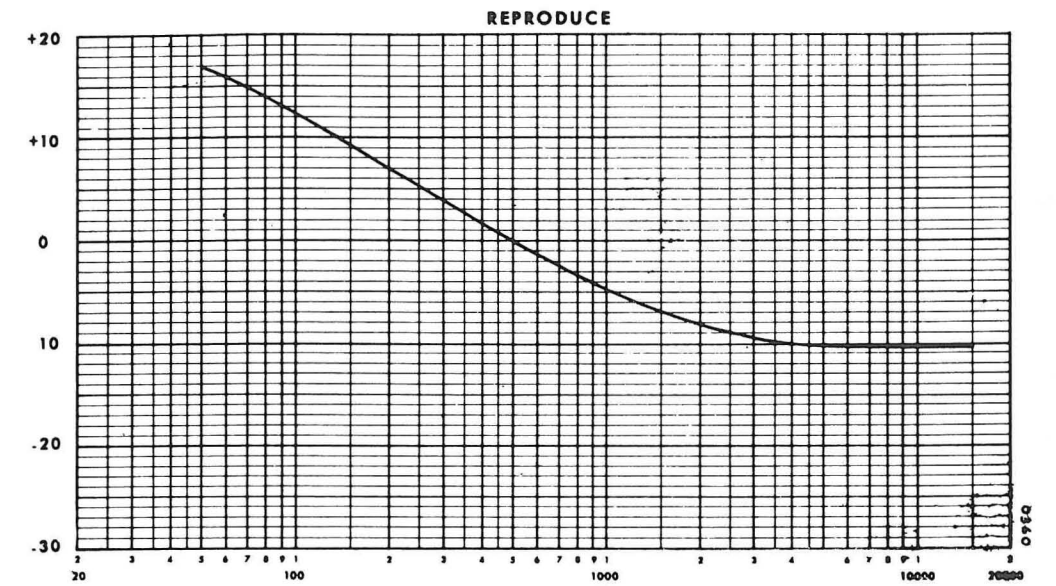

Fig. 6-32. Response Curves, Sheet 1



7 1/2 ips CCIR



15 ips CCIR

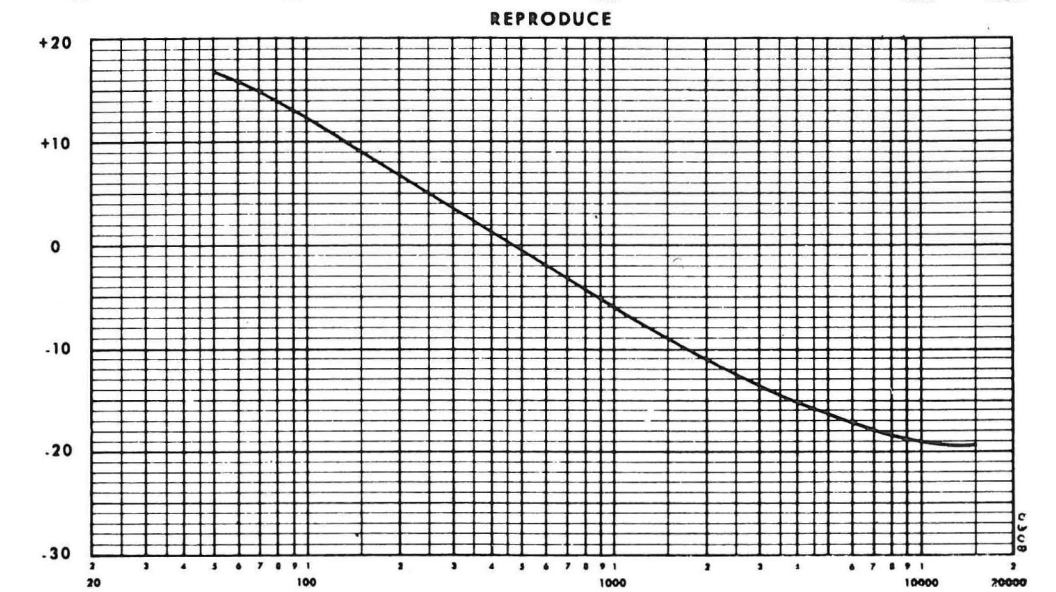
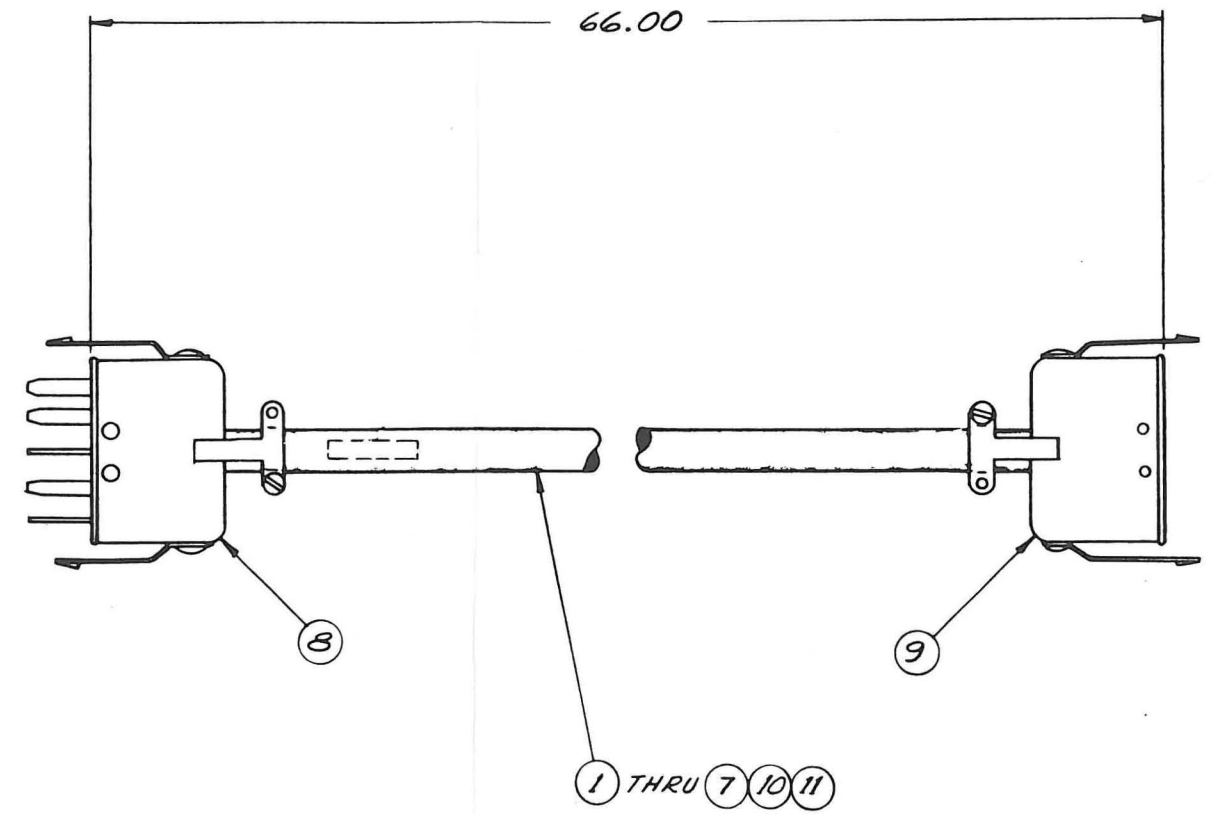

Fig. 6-33. Response Curves, Sheet 2



1		1
2		2
3	YEL	3
4		4
5	GRN	5
6	BLU	6
7	VIO	7
8	GRY	8
9	WHT	9
10	BLK	10

SCHEMATIC DIAGRAM

PART NO.	L
4050416-01	120"

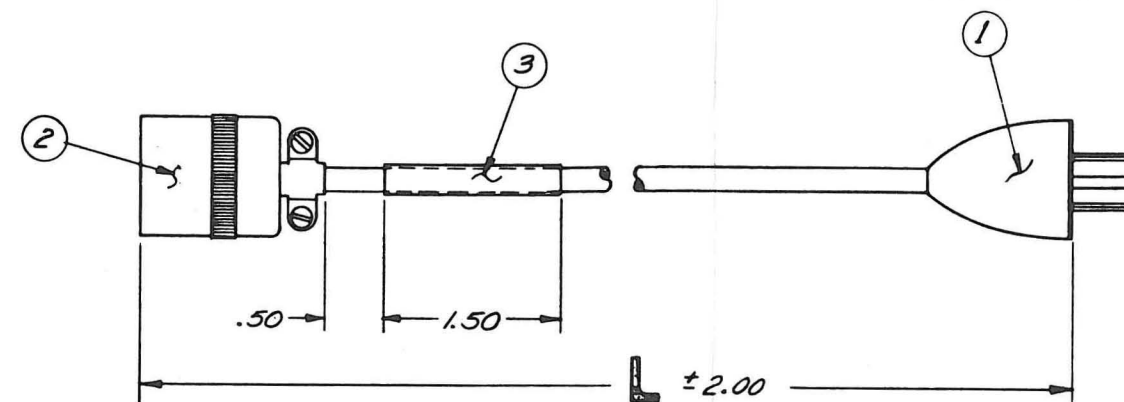
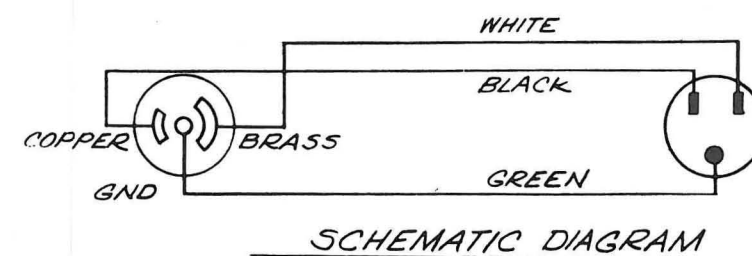

Fig. 6-35. Cable, Power
6-45

Section 7

MODIFICATION PROCEDURES**Part A. Tape Transport Mode Alterations****7A.1** GENERAL

The following instructions give requirements for defeating the mode controls on the Model AG-440 and AG-445 tape transport. A simplified schematic diagram of the tape transport control system is given in Figure 7A-1. All parts are shown on the interior view of the control box assembly, Figure 7A.

7A.2 MODIFICATION PROCEDURES

7A.2.1 **MODIFICATION TO ENTER ANY OTHER MODE DIRECTLY FROM THE RECORD MODE.** This defeats the safety feature that normally prevents entering any other mode from the record modes without first stopping tape motion.

- a. Connect a jumper wire from Q601 emitter to the negative side of diode CR605.
- b. Disconnect the base lead of Q601 (to protect the transistor).

7A.2.2 **MODIFICATION TO DEFEAT ALL, OR ANY, OF THE EDIT FUNCTIONS.**

The three edit modes of the AG-440/AG-445 are stop/edit, play/edit, and fastwinding/edit.

- a. To defeat the stop/edit mode, disconnect the lead connected to pin 6 of edit relay K603.
- b. To defeat the play/edit mode, connect one jumper wire from pin 4 to pin 12, and one from pin 2 to pin 10, on edit relay K603.
- c. To defeat the fastwinding/edit mode, connect a jumper wire across the normally closed contacts of EDIT switch S611.
- d. To defeat all edit modes, disconnect the wire from either side (pin 13 or pin 14) of edit relay coil K603 and connect a jumper wire across the normally closed contacts of EDIT switch S611.

7A.2.3 MODIFICATION TO ENTER THE
PLAY/EDIT MODE BY PRESSING
THE EDIT PUSHBUTTON (WHEN
TAPE IS STOPPED) EVEN WHEN
THE SAFETY SWITCH IS OPEN.

- a. Disconnect the four wires from the EDIT pushbutton switch S611, and remove the switch. Replace switch with a DPDT momentary pushbutton-controlled micro-switch with two normally-open contacts (Licon 79-2920 or equivalent).
- b. Connect the two wires disconnected from the normally-open contacts of the original switch to either open contact of the new switch. Solder the ends of the other two disconnected wires together, and tape the connection (this forms the same circuit as the jumper wire connected in step c of the preceding paragraph).
- c. Connect the other open contacts on the new switch to pin 8 and pin 12 of edit relay K603.
- d. Connect a jumper wire across pin 7 and pin 9 of edit relay K603.

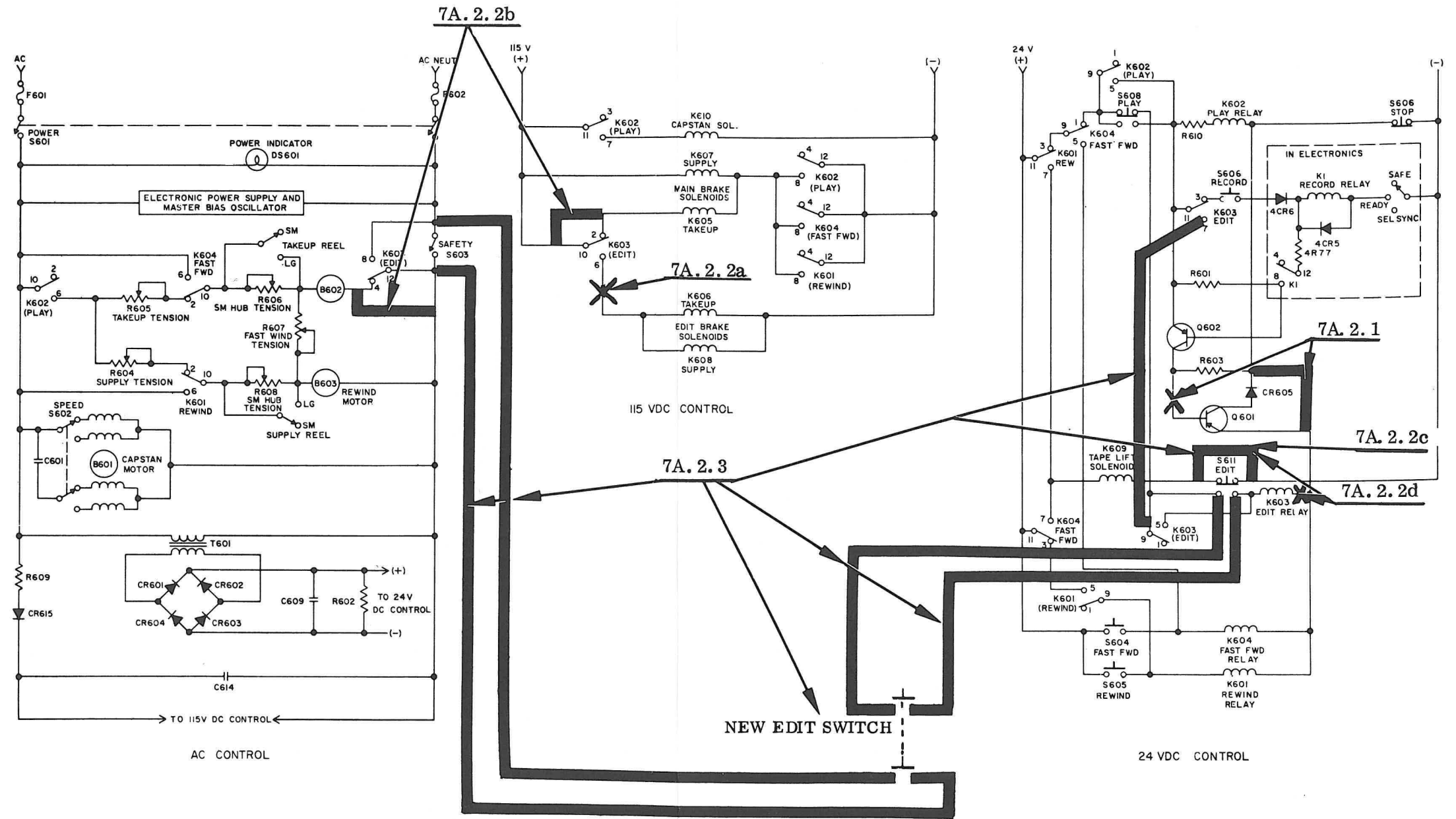

Fig. 7A-1. Tape Transport Mode Alterations

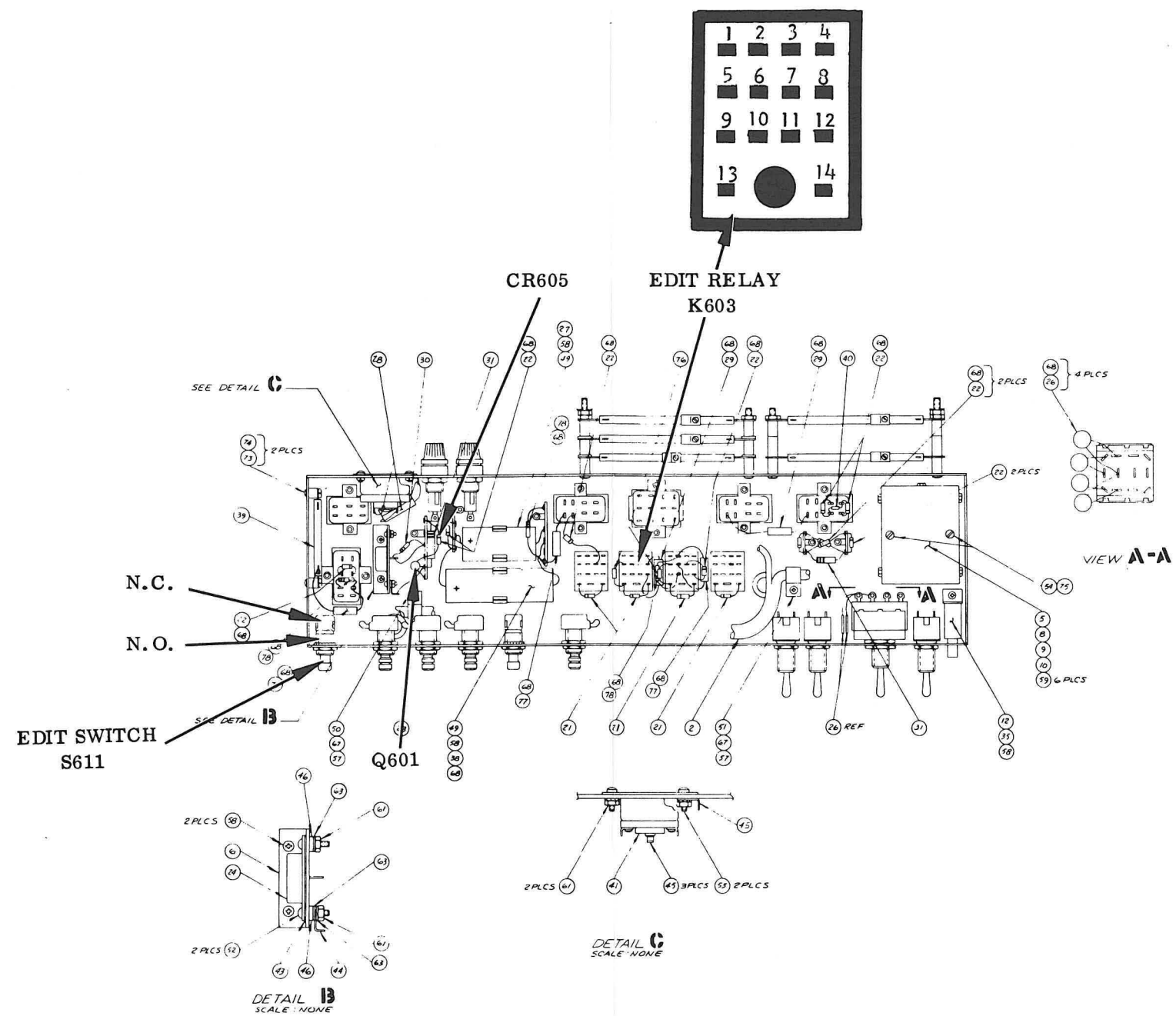

Fig. 7A-2. Control Box Components

Section 7

MODIFICATION PROCEDURES

Part B. External Motor Drive Amplifier Addition

7B.1 GENERAL

To obtain Underwriters' Laboratory approval for the Ampex AG-440B/445B tape transport control panel, it was necessary to disconnect receptacle J604S. The J604S connector was originally provided for external inputs from a motor drive amplifier.

Modification procedures in this section give instructions for wiring receptacle J604S, and describe other wiring changes necessary for operation of the AG-440B/445B with an external motor drive amplifier.

NOTE

If the entire installation requires Underwriters' Laboratory approval, all internal wiring, and the motor drive amplifier, must meet Underwriters' Laboratory requirements.

7B.2 INTERNAL WIRING ADDITIONS AND CHANGES

Proceed as follows to modify internal wiring of the transport control box:

Step 1: Remove transport control box as directed in paragraph 4E.11.2 of this instruction manual (Section 4).

Step 2: Locate SPEED switch S602 and receptacle J607S.

Step 3: Locate the white-violet wire between terminal A of switch S602 and pin 3 or 4 of receptacle J607S. (Note that there are two white-violet wires soldered to terminal A of S602; determine which wire goes to receptacle J607S.)

Step 4: Unsolder white-violet wire from J607S (pin 3 or 4) and from terminal A of switch S602. Remove this white-violet wire from wiring harness.

Step 5: Connect and solder a new white-violet wire to S602 terminal A; route wire to J604S; and solder white-violet wire to pin 7 of J604S. (See Figure 7B-1.)

Step 6: Locate pin 5 of receptacle J604S and pins 5 and 6 of receptacle J602S.

Step 7: Solder violet wire between pin 5 of J604S and pins 5 and 6 of J602S.

Step 8: Locate pin 2 of receptacle J606S and pin 1 of receptacle J604S.

Step 9: Solder white wire between pin 2 of receptacle J606S and pin 1 of receptacle J604S.

Step 10: Transport control box wiring modification is complete. Refer to Figures 7B-1 and 7B-2 to verify wiring changes are correct.

7B.3 CONNECTING MOTOR DRIVE AMPLIFIER

CAUTION

The output from the motor drive amplifier must be isolated from the main ac power source. Failure to observe this caution may result in extensive damage to transport control circuits.

To connect motor drive amplifier (MDA) to transport control box, the MDA plug, Ampex 145-013 (H.B. Jones, P-308-CCT-L), must be prepared as follows, and then inserted in receptacle J604S:

Step 1: Connect input power to the MDA from pins 1 and 5 (low side of ac line) of MDA mating plug. (This connection assigns power control to the tape transport POWER switch and safety switch.)

Step 2: Connect MDA precision frequency power output to return to the tape transport through pins 7 (low) and 8 (hot) of MDA mating plug.

Step 3: Verify that wiring is correct; then insert MDA mating plug in receptacle J604S. Connection of MDA is complete.

7B.4 PREPARING DUMMY PLUG

For occasional use of the equipment with power directly from the power mains, a dummy plug must be used. Use the same mating plug described in paragraph A2-3 and wire it as follows:

Use bare 20-gauge wire to jumper the plug pins 7 and 1 (see Fig. 7B-2). To change operation from the motor drive amplifier to the power line, unplug the amplifier connector from J604S and insert the dummy plug.

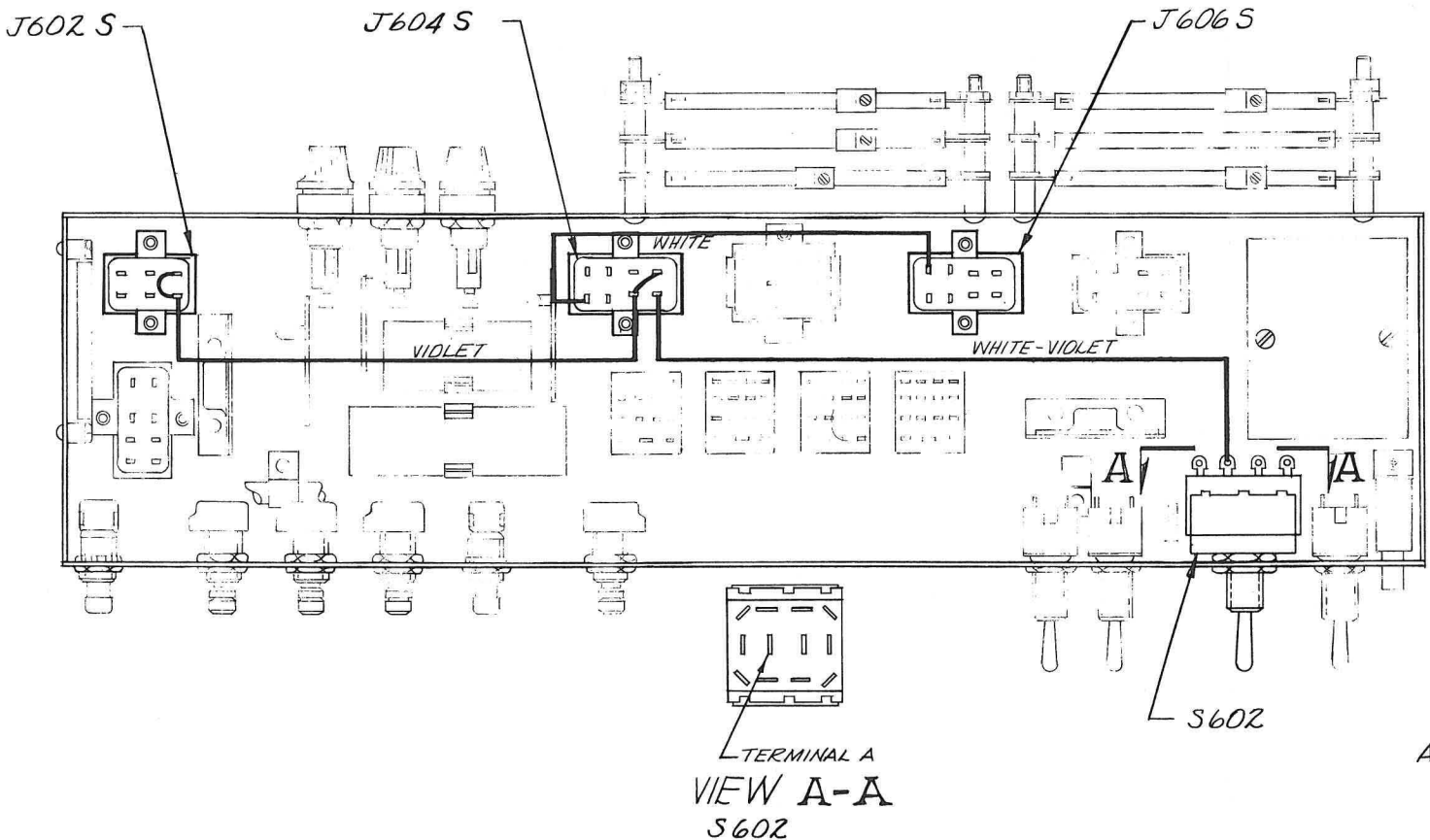
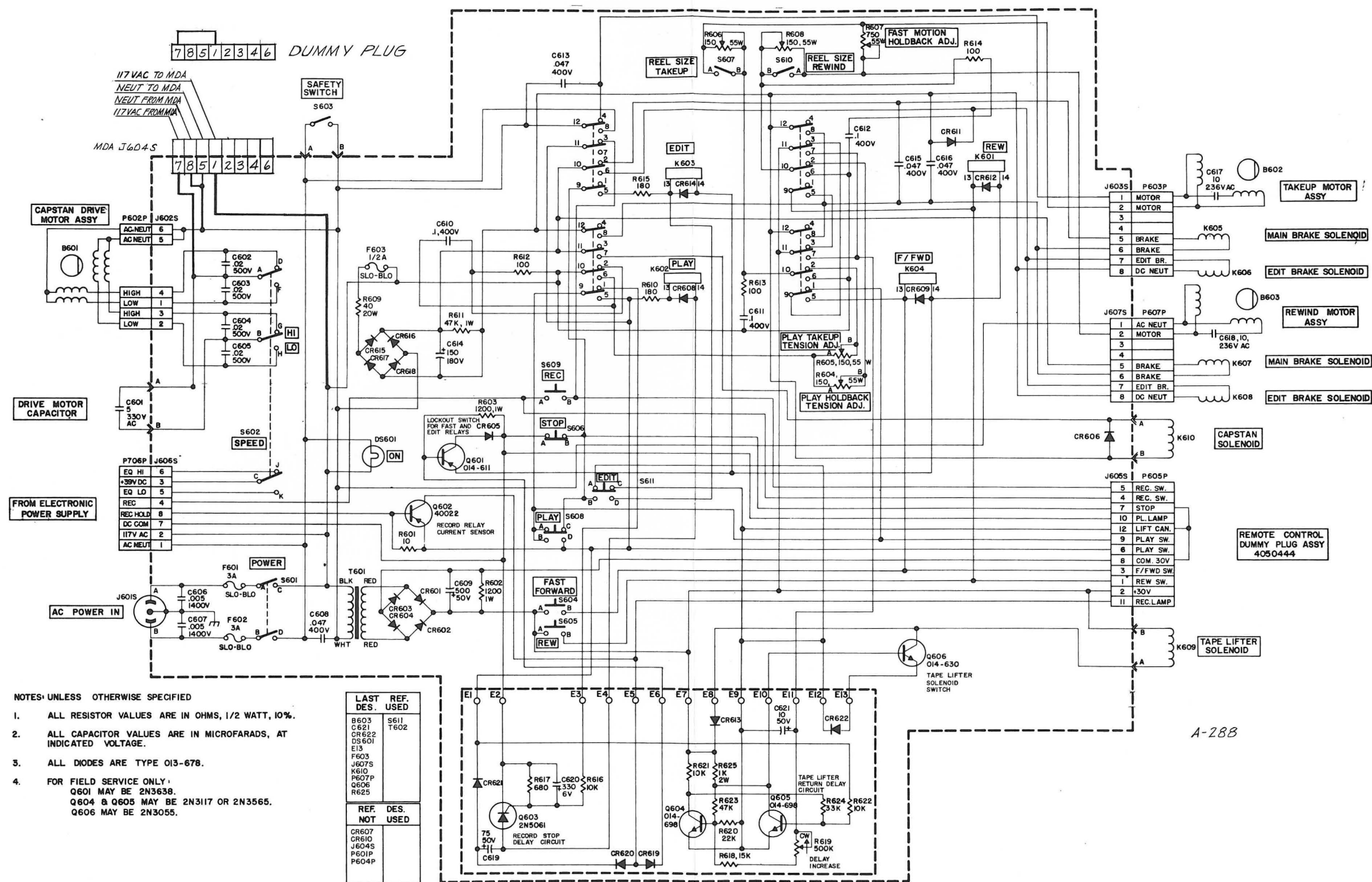

Figure 7B-1. Wiring Changes Required for Connection of External Motor Drive Amplifier



- NOTES: UNLESS OTHERWISE SPECIFIED
1. ALL RESISTOR VALUES ARE IN OHMS, 1/2 WATT, 10%.
 2. ALL CAPACITOR VALUES ARE IN MICROFARADS, AT INDICATED VOLTAGE.
 3. ALL DIODES ARE TYPE O13-678.
 4. FOR FIELD SERVICE ONLY: Q601 MAY BE 2N3638. Q604 & Q605 MAY BE 2N3117 OR 2N3565. Q606 MAY BE 2N3055.

LAST DES.	REF. USED	DES.	REF. USED
B603	S611	T602	
C621			
CR622			
DS601			
E13			
F603			
J607S			
K610			
P607P			
Q606			
R625			
CR607			
CR610			
J604S			
P601P			
P604P			

Figure 7B-2. Transport Control Box Modified for Use with External Motor Drive Amplifier, Schematic

Section 7

MODIFICATION PROCEDURES**Part C. Sel-Sync[®] Remote Control****7C.1** DESCRIPTION

The remote control Sel Sync system, Catalog No. 4010129, for a AG-440 recorder/reproducer that uses up to four channels, consists of a switching unit (Catalog No. 4020286) and a control unit 4020294-01. The system provides remote control for all the Sel Sync functions.

Equipment with five to eight channels requires the Catalog No. 4010130 system, which contains two of the same switching units (Catalog No. 4020286) and a control unit 4020294-02.

NOTE

If receptacle J14 is not included on the record/reproduce electronic unit(s), order Ampex Remote Sel Sync Modification Kit No. 4850111-01, for a recorder/reproducer with up to four channels; or No. 4850111-02, for a

recorder/reproducer with from five to eight channels.

7C.2 SWITCHING UNIT**7C.2.1** **GENERAL**

One switching unit is required for recording up to four channels, and two identical units are required for five to eight channels. The following instructions describe the mounting and connecting of each switching unit (all interconnecting cables required are supplied).

7C.2.2 **MOUNTING**

Mount the unit close to the recorder/reproducer (so head cables need not be lengthened) and in a standard 19-inch rack; or in the Ampex console with two electronic supports (Ampex Catalog No. 4260404).

7C.2.3 **CONNECTING**

Step 1: Disconnect all record head cables from the J6 (RECORD) receptacle of each

record/reproduce unit. Connect the cables to the corresponding REC HEAD receptacles on the switching unit.

Step 2: Disconnect all reproduce head cables from the J1 (REPRO) receptacles of each record/reproduce unit. Connect those cables to the REP HEAD receptacles on the switching unit.

Step 3: Connect the record head jumper cables (Catalog No. 4050207-09, supplied) between the REC ELECTRONICS receptacle on the switching unit and all J6, RECORD receptacles according to channel numbers.

Step 4: Connect the reproduce head jumper cables (Catalog No. 4050471-01, supplied) between the REP ELECTRONICS receptacles on the switching unit and all J1 (REPRO) receptacles according to channel numbers.

NOTE

For equipment using two power supplies (5 to 8 channels) a dual power jumper cable, Catalog No. 4050483-01, is supplied.

Step 5: On each tape transport power supply, disconnect any one of the cables from receptacles J701 through J704. Connect the 10-prong plug on the Y-type power jumper cable (Catalog No. 4050466-01, supplied) to the vacated receptacle. Connect the disconnected cable to the 10-socket plug on the power jumper cable.

Step 6: For each switching unit, connect the 4-prong plug on the power jumper cable to J3 (POWER SUPPLY) receptacle.

Step 7: Connect the Catalog No. 4050467-02 cable (supplied) between the switching unit J2 (ELECTRONICS) receptacle, and each record/reproduce unit J14 (four-pin) receptacle.

7C.3 CONTROL UNIT

7C.3.1 GENERAL

The two versions of the control unit are Catalog No. 4020294-01, for equipment with up to four channels; and Catalog No. 4020294-02, for equipment with up to eight channels. Two 30-foot captive cables provide interconnecting facilities and limit the distance between the control unit and the recorder/reproducer.

7C.3.2 MOUNTING

The control unit, furnished in a desk top case, may also be mounted in a console cutout by removing the case and using the unit as a cutout template; small slots in the upper and lower edges are for mounting hardware.

7C.3.3 CONNECTING

Connect each 21-prong plug to the switching unit J1 (REMOTE) receptacle. For eight channel equipment, connect the two 21-prong plugs. Connect the 12-prong plug to the tape transport J605S (REMOTE CONTROL) receptacle.

7C.4 REMOTE OPERATION

7C.4.1 RECORDING

7C.4.1.1 Normal Recording

Step 1: At the recorder/reproducer:

- a. Thread tape on the tape transport.
- b. Select desired tape speed.
- c. Set REEL switches for reel hub sizes in use.
- d. Set desired record and reproduce levels.
- e. Set all RECORD SELECTOR switches to READY (always at ready when using the Sel Sync remote control).

- f. To monitor the recording as it is recorded, set OUTPUT SELECTOR switches on desired channels to REPRO. To monitor the material before it records, set the switches to INPUT.

Step 2: At remote control, the PLAY REPRO pushbutton should be lighted.

Step 3: At remote control, set SAFE-READY switches on channels to be recorded at READY (READY indicators light) and on other channels at SAFE.

NOTE

To remove a channel from the record mode at any time, change the channel SAFE-READY switch setting from READY to SAFE. To initiate recording on a channel at any time, change the channel SAFE-READY switch setting from SAFE to READY, and press the RECORD pushbutton.

Step 4: Start recording by pressing the PLAY pushbutton (tape starts and PLAY indicator lights), then pressing the RECORD pushbutton. All channels in the "ready" condition will record (RECORD indicator lights).

Step 5: Stop recording by pressing the STOP pushbutton (tape motion stops).

7C.4.1.2 Sel Sync Recording

Step 1: Make the first recording run according to paragraph 7C.3.1.1).

Step 2: Rewind the tape and align heads to the beginning of the recording. At the recorder/reproducer, set OUTPUT SELECTOR switches for the recorded channels to REPRO.

Step 3: At remote control, set READY-SAFE switch(es) for the recorded channel(s) to SAFE.

Step 4: For the channel(s) to record the second run, set READY-SAFE switch(es) to SAFE.

Step 5: Press the SYNC REPRO pushbutton (pushbutton lights and PLAY REPRO pushbutton goes out).

Step 6: Have the performer don a headset monitor.

Step 7: Press PLAY, then RECORD pushbuttons. The performer hears any previously recorded track so he can sing or play in synchronism with it. Press the STOP pushbutton to stop recording.

Step 8: For each additional recording run, repeat the procedure. Before starting a run, be sure that the remote control READY/SAFE switches for all previously recorded channels are set to SAFE.

7C.4.2 REPRODUCING

Step 1: At the recorder/reproducer:

- a. Thread tape on the tape transport.
- b. Select desired tape speed.
- c. Set REEL switches for reel hub sizes in use.
- d. Set desired reproduce level.
- e. Set desired OUTPUT SELECTOR switches to REPRO.
- f. Set all RECORD SELECTOR switches to SAFE.

Step 2: Press PLAY pushbutton (tape starts in motion in the reproduce mode).

Step 3: Press the STOP pushbutton (tape stops).

7C.4.3 FAST-WINDING

For tape editing or cueing, the tape is rapidly wound by pressing the REWIND or FAST FWD pushbuttons. The pushbuttons can be pressed alternately, without first stopping tape motion. When the desired tape area is reached, press the STOP pushbutton (if tape runs off either reel, operation will automatically stop). Either fast-winding mode can also be entered from the stop or play modes, but is locked-out when in the record, or play/edit mode (in play/edit the takeup tension arm doesn't hold the safety switch closed, thus fast-winding is locked-out).

To enter other modes from the fast-winding modes, press the STOP pushbutton, then when tape motion stops, actuate the control for the mode selected.

CAUTION

Allow fast-winding tape motion to stop before pressing the PLAY pushbutton to avoid breaking or stretching the tape.

Two automatic tape-lifter arms (removing tape from head contact) are automatically actuated in both fast-winding modes. For fast-winding audio monitoring, the EDIT pushbutton is then pressed (this overrides the tape lifter).

7C.4.4 EDIT MODE

Fast-winding edit, the only edit mode available at the remote control, is entered by pushing the EDIT pushbutton when operating in the fast-forward or rewind mode; this overrides the tape lifter so audio monitoring is possible. This mode is primarily for quickly reaching a desired tape area (rough cueing).

7C.5 ADJUSTMENTS

7C.5.1 GENERAL

Adjustments available, both on the switching unit, are for the Sel Sync and bias trap signal levels. For level adjustments, obtain the applicable Ampex Standard Alignment Tape listed on Table 1.

7C.5.2 SEL SYNC LEVEL ADJUSTMENT

Step 1: Set each record/reproduce unit RECORD SELECTOR switch and all READY-SAFE switches to SAFE.

Step 2: Thread the correct Standard Alignment Tape on the tape transport.

Step 3: Set all record/reproduce unit OUTPUT SELECTOR switches to REPRO.

Step 4: Move the alignment tape to the operating-level tone (the first tone on 15 ips tapes, and the last tones on tapes for slower speeds).

Step 5: Initiate the play mode. As the operating level tone is reproduced, adjust all record/reproduce unit REPRODUCE LEVEL controls for a 0 indication on the VU meters. At the remote control, press the SYNC REPRO pushbutton.

Step 6: Rewind tape and replay the operating-level tone as necessary to adjust all SYNC GAIN controls (on the switching unit back panel) for a 0 indication on the VU meters.

Step 7: Remove and store the alignment tape.

7C.5.3 SEL SYNC BIAS TRAP ADJUSTMENT

When Sel Sync is used, the bias from a recording channel could leak into an adjacent channel so that nothing would be recorded on the latter channel. Monitoring with the VU meters might also be masked.

Traps provided on the switching unit and on each record/reproduce unit minimize such bias leakage. The bias trap is adjusted at the factory, so there should be no need for readjustment. If the bias from recording channels causes objectionable VU meter indications on channels operating in Sel Sync, adjust as follows: Operate one channel at a time under Sel Sync, and all other channels in the record mode. Adjust each Sel Sync BIAS TRAP control (on the record/reproduce unit back panel) to null the VU meter indication. Operate system from remote control and repeat the above procedure, to adjust each TRAP ADJ control to null the leakage indication.

TAPE SPEED	TYPE OF EQUALIZATION	ALIGNMENT TAPE	
		1/4-inch	1/2-inch
15 ips	NAB	01-31311-01	01-31311-05
	CCIR	01-31313-01	01-31313-05
7-1/2 ips	NAB	01-31321-01	01-31321-05
	CCIR	01-31323-01	01-31323-05
3-3/4 ips	120 micro sec	01-31331-01	-----
	200 micro sec	01-31334-01	

Table 7C-1. Standard Alignment Tapes

REMOTE CONTROL SEL SYNC
FOUR CHANNELS
System Catalog No. 4010129-01

Qty -01	DESCRIPTION	Ampex Part No.
1	Switching Unit, Sel Sync	4020286-02
1	Control Unit, Sel Sync	4020294-01
4	Cable, record head	4050207-09
1	Cable, power supply jumper	4050466-01
1	Cable, interconnecting	4050467-02
4	Cable, reproduce head	4050471-01
1	Instruction pamphlet	4890191

REMOTE CONTROL SEL SYNC
EIGHT CHANNELS
System Catalog No. 4010130-01

Qty -01	DESCRIPTION	Ampex Part No.
2	Switching Unit, Sel Sync	4020286-02
1	Control Unit, Sel Sync	4020294-02
8	Cable, record head	4050207-09
1	Cable, power supply jumper	4050483-01
2	Cable, interconnecting	4050467-02
8	Cable, reproduce head	4050471-01
1	Instruction pamphlet	4890191

SWITCHING UNIT
Sel Sync

Ref. No.	Qty	DESCRIPTION	Ampex Part No.
	-02	Switching Unit, Sel Sync	
C1	4	Capacitor, variable; 1,400 to 3,055 pfd	4020286-02
C2	4	Capacitor, mica; 1,500 pfd, ±5%	038-011
C3	x	Same as C1	056-021
C4	x	Same as C2	
C5	x	Same as C1	
C6	x	Same as C2	
C7	x	Same as C1	
C8	x	Same as C2	
C9	4	Capacitor, ; 2.2 mfd, ±20%, 35 vdc	037-107
C10	x	Same as C9	
C11	x	Same as C9	
C12	x	Same as C9	
CR1	4	Diode, silicon; large signal rectifier	013-678
CR2	x	Same as CR1	
CR3	x	Same as CR1	
CR4	x	Same as CR1	
CR5	8	Diode, silicon; small signal switching	013-599
CR6	x	Same as CR5	
CR7	x	Same as CR5	
CR8	x	Same as CR5	
CR9	x	Same as CR5	
CR10	x	Same as CR5	
CR11	x	Same as CR5	
CR12	x	Same as CR5	
J1	1	Connector, receptacle, female; 21 sockets	146-057
J2	1	Connector, receptacle, male; 15 pins	147-007
J3	1	Connector, receptacle, female; 4 sockets	146-005
J4	8	Connector, receptacle, male; 2 pins	143-009
J5	x	Same as J4	
J6	x	Same as J4	
J7	x	Same as J4	
J8	x	Same as J4	
J9	x	Same as J4	
J10	x	Same as J4	
J11	x	Same as J4	
J12		Connector, receptacle, male; 3 pin	143-008
J13	x	Same as J12	
J14	x	Same as J12	
J15	x	Same as J12	
J16	x	Same as J12	
J17	x	Same as J12	
J18	x	Same as J12	
J19	x	Same as J12	
K1	4	Relay	020-577
K2	x	Same as K1	
K3	x	Same as K1	
K4	x	Same as K1	
Q1	1	Transistor, silicon; npn, power type	014-587
Q2	4	Transistor, silicon; compound npn	014-969
Q3	x	Same as Q2	
Q4	x	Same as Q2	
Q5	x	Same as Q2	
R1	1	Resistor, fixed, composition; 1,000 ohms, ±10%, 1w	041-146
R2	4	Resistor, variable, composition; 5,000 ohms, ±20%, 3/10w, linear taper	4520154-02
R3	x	Same as R2	
R4	x	Same as R2	
R5	x	Same as R2	
R6	4	Resistor, fixed, composition; 68,000 ohms, ±10%, 1/2w	041-070
R7	x	Same as R6	
R8	x	Same as R6	
R9	x	Same as R6	
VR1	1	Diode, Zener, 24 volts	013-712
	4	Spring, relay hold down	020-584
	4	Socket, relay	150-256

CONTROL UNIT
Sel Sync

4890301-01

Ref. No.	Qty -01	Qty -02	DESCRIPTION	Ampex Part No.
	x		Control Unit, four channels	4020294-01
		x	Control Unit, eight channels	4020294-02
CR1	3	3	Diode, silicon	013-678
CR2	x	x	Same as CR1	
CR3	x	x	Same as CR1	
DS1	4	8	Lamp, 28 volt, amber; READY	132-099
DS2	x	x	Same as DS1	
DS3	x	x	Same as DS1	
DS4	x	x	Same as DS1	
DS5	-	x	Same as DS1	
DS6	-	x	Same as DS1	
DS7	-	x	Same as DS1	
DS8	-	x	Same as DS1	
DS9	2	2	Lamp, 28 volt; SYNC REPRO	060-019
DS10	x	x	Same as DS-9; PLAY REPRO	
DS11	1	1	Lamp, 28 volt, red; RECORD	132-100
DS12	1	1	Lamp, 28 volt, green; PLAY	060-338
K1	1	1	Relay, 4 pole double throw	020-144
R1	3	3	Resistor, fixed, composition; 180 ohms, ±10%, 1/2W	041-257
R2	x	x	Same as R1	
R3	x	x	Same as R1	
S1	4	8	Switch, dpdt; READY-SAFE	120-842
S2	x	x	Same as S1	
S3	x	x	Same as S1	
S4	x	x	Same as S1	
S5	-	x	Same as S1	
S6	-	x	Same as S1	
S7	-	x	Same as S1	
S8	-	x	Same as S1	
S9	2	2	Switch, pushbutton; SYNC REPRO	120-726
S10	x	x	Same as S9; PLAY REPRO	
S11	3	3	Switch, momentary; normally open; REWIND	4620144-10
S12	x	x	Same as S11; FAST FORWARD	
S13	1	1	Switch, momentary; normally open; RECORD	4620144-30
S14	x	x	Same as S11; PLAY	
S15	2	2	Switch, momentary; normally closed; STOP	4620144-20
S16	x	x	Same as S15; EDIT	
	1	1	Bracket, relay	4260128-01
	1	1	Bracket, switch	4260127-01
	1	1	Button, "PLAY REPRO"	4100066-01
	1	1	Button, "SYNC REPRO"	4100066-02
	3	3	Button, white	4100183-01
	1	1	Button, yellow	4100183-02
	1	1	Button, red	4100183-03
	1	1	Button, green	4100183-04
	1	-	Cable assembly, captive; 21 terminal	4050481-01
	-	1	Cable assembly, captive; 21 terminal	4050482-01
	1	1	Cable assembly, captive; 12 terminal	
	1	1	Housing, remote Sel Sync	
			Back	4150197-01
			Front	4150198-01
			Base	4330097-01
			Feet, rubber	250-017
	1	1	Panel, switch	4290686-01
	6	10	Retainer, lamp	435-069
	1	1	Socket, relay	150-119

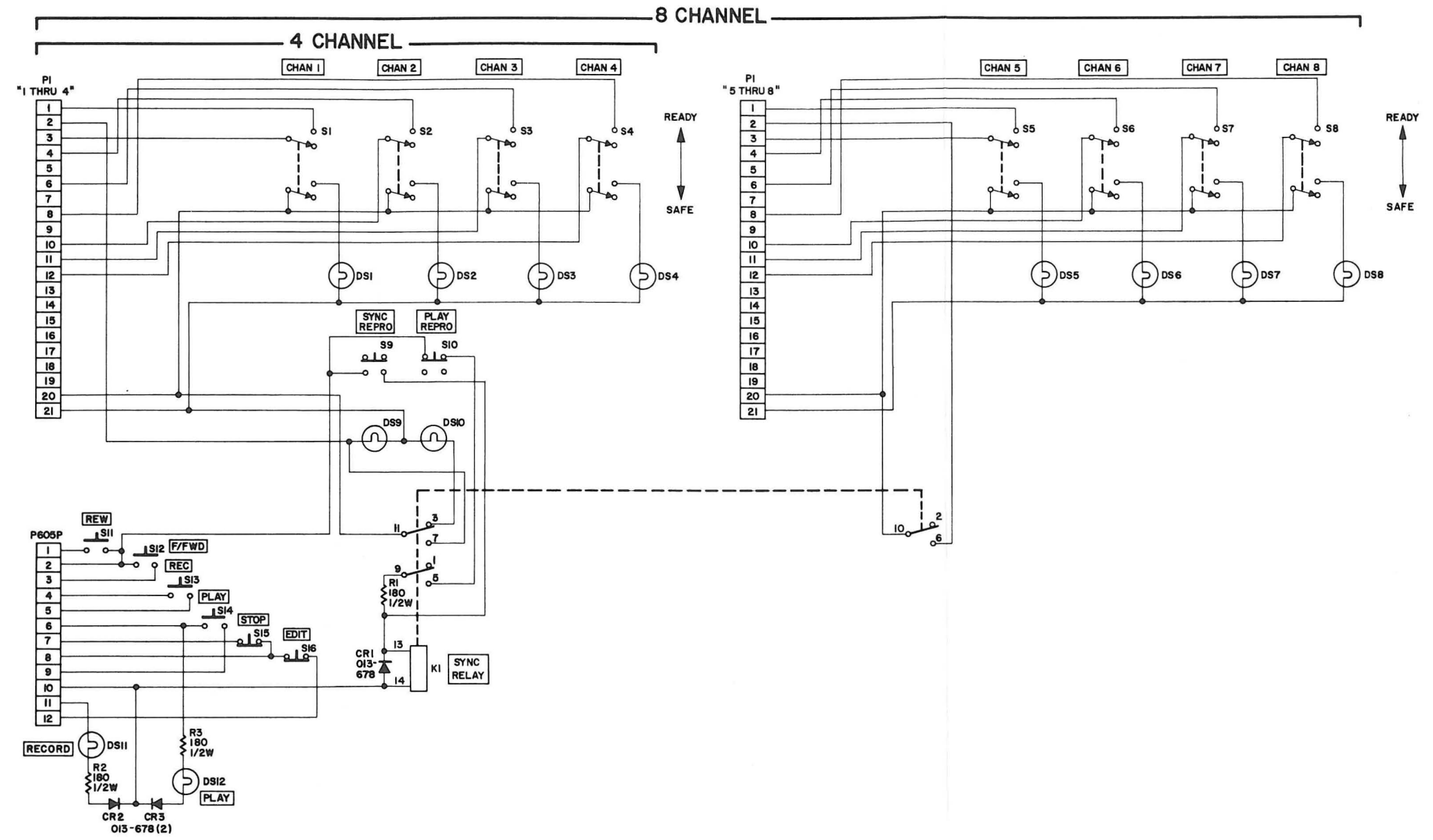

Fig. 7C-1. Control Unit Schematic

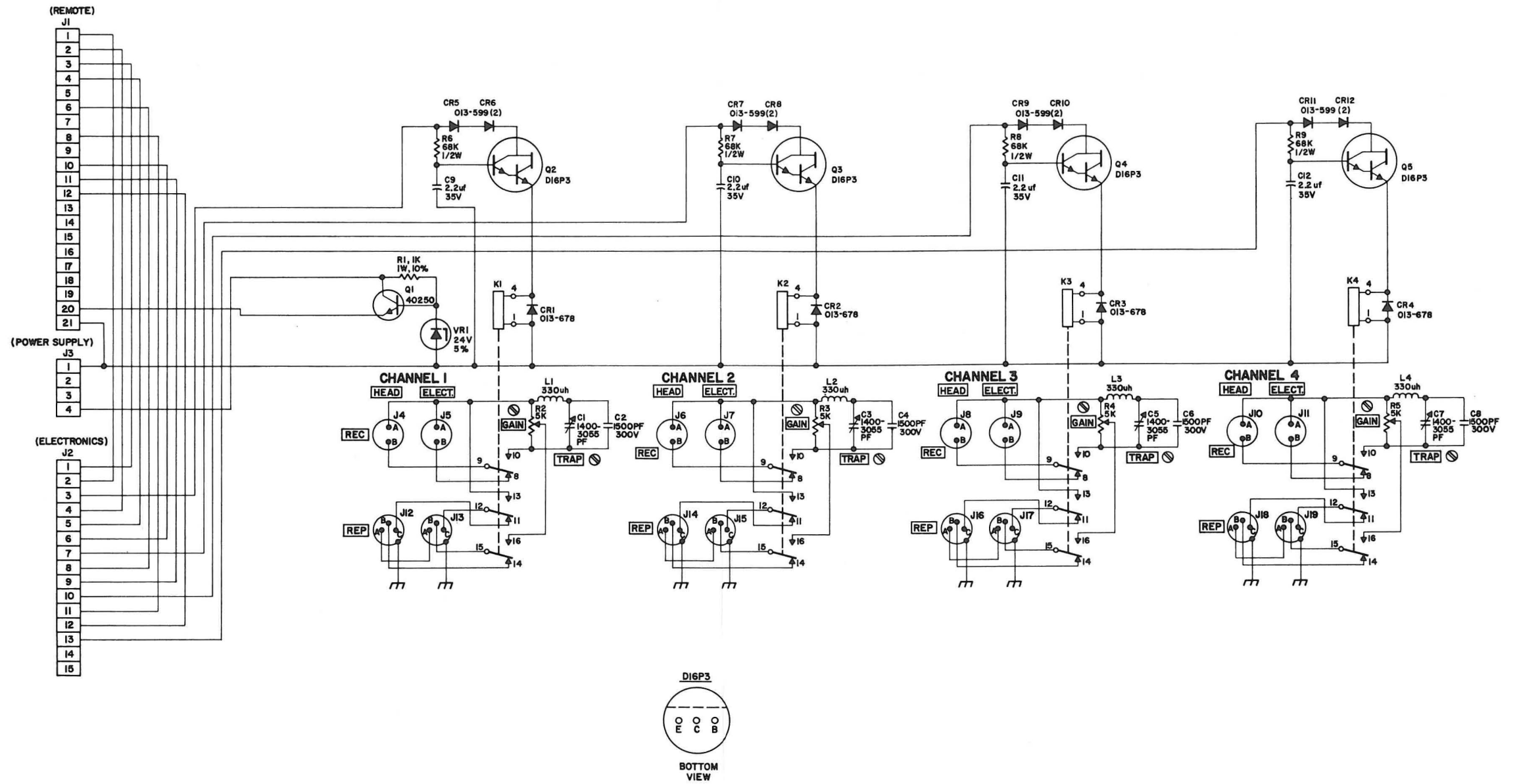

Fig. 7C-2. Switching Unit Schematic

AMPEX
PRINTED IN USA